

SYSTEM DRIVES

# ACS1000 air-cooled

## User manual



OWNING ORGANIZATION System Drives, ABB Switzerland Ltd.	DATE 2025-03-12	STATUS Approved	SECURITY LEVEL Public		
DOCUMENT KIND User manual		DOCUMENT ID. 3BHS213401 E01	REV. N	LANG. en	PAGE 1/160

---

## LEGAL DISCLAIMER

This document contains information about one or more ABB products and may include a description of or a reference to one or more standards that are relevant to the ABB products. The presence of any such description of a standard or reference to a standard is not a representation that all of the ABB products referenced in this document include all the features of the described or referenced standard. In order to determine the specific features included in a particular ABB product, the product specifications for the particular ABB product apply.

The buyer acknowledges the proprietary and confidential nature of the information contained in this document and agrees that all rights to and concerning the information contained in this document remain vested in ABB, in particular with regard to any intellectual property rights. Nothing contained herein shall oblige ABB to furnish any particular information to the buyer.

The information in this document is subject to change without notice and should not be construed as a binding declaration of ABB. ABB assumes no responsibility for any errors or omissions in this document.

Products described or referenced in this document are designed to be connected with networks and provide information and data through network interfaces. The products must be connected to a secure network. It is the sole responsibility of the buyer of the products to provide and continuously ensure a secure connection between the product and the system network and/or any other networks that may be connected to the product. ABB is in no event liable for the security of the network used by buyer.

The buyer of the product must establish and maintain appropriate measures, including, but not limited to, the installation of firewalls, application of authentication measures, encryption of data, installation of antivirus programs, and so on, to protect these products, the network, its system, and interfaces against security breaches, unauthorized access, interference, intrusion, leakage, and/or theft of data or information. Any liability of ABB in this regard is excluded.

ABB may perform functionality testing on the products and may release updates. However, it is the sole responsibility of the buyer of the product to ensure that any product updates or other major system updates (to include but not limited to code changes, configuration file changes, third-party software updates or patches, hardware change out, and so on) are compatible with the security measures implemented. The buyer of the product must verify that the system and associated products function as expected in the environment in which they are deployed. ABB has no obligations in this regard.

In no event shall ABB be liable for any damages inclusive but not limited to indirect, special, incidental or consequential damages of any nature or kind whatsoever arising from the use of this document, nor shall ABB be liable for any damages inclusive but not limited to indirect, special, incidental or consequential damages arising from the use of any software or hardware described in this document.

This document and parts thereof must be kept strictly confidential and must not be reproduced or copied without the prior written permission from ABB, and the contents thereof must not be disclosed or made available to any third party nor used for any unauthorized purpose.

The software or hardware described in this document may be furnished under a license and may be used, copied, or disclosed only in accordance with the terms of such license.

---

## TRADEMARKS

ABB is a registered trademark of ASEA BROWN BOVERI LTD.

All rights to copyrights, registered trademarks, and trademarks reside with their respective owners.

Copyright © 2025 ABB.

All rights reserved.

PRODUCT	DOCUMENT KIND	DOCUMENT ID.	REV.	LANG.	PAGE
ACS1000A	User manual	3BHS213401 E01	N	en	2/160

## CONTENTS

<b>1. About this manual</b>	<b>11</b>
1.1. Equipment covered by this manual	11
1.2. Structure of the user documentation	11
1.3. Terms and abbreviations	12
1.4. Related documents	14
1.4.1. Maintenance	14
1.4.2. Technical data	14
1.4.3. Schematics	14
1.4.4. Specifications and guidelines	14
1.4.5. Serial communication interfaces	14
1.4.6. Encoder	14
1.5. Target groups and required qualification	15
1.5.1. Handling	15
1.5.2. Mechanical installation	15
1.5.3. Electrical installation	15
1.5.4. Operation	15
1.5.5. Maintenance	15
1.6. User's responsibilities	16
1.7. Intended use of equipment	16
1.8. Quality certificates and applicable standards	16
1.9. Items covered by delivery	17
1.10. Identifying the delivery	17
1.11. Document conventions	18
<b>2. Important safety information</b>	<b>19</b>
2.1. Safety messages and safety signs in this document	19
2.1.1. Safety messages	19
2.1.2. Safety signs	19
2.2. Product safety labels	20
2.3. Electrical safety	20
2.3.1. General safety instructions	20
2.3.2. The seven steps that save lives	21
2.3.3. Possible residual risks	23
2.4. Main circuit breaker protection device	24
2.4.1. Safety and protection requirements	25
2.4.2. Minimum requirements for MCB and MCB control	25
2.5. Maintenance recommendation	26
<b>3. Power electronics and cabinet features</b>	<b>27</b>
3.1. Overview	27
3.2. Drive topology	28
3.3. Power supply configurations	29
3.3.1. Main power supply configurations	29
3.3.2. Auxiliary power supply configurations	30
3.4. Drive topology	31
3.4.1. Overview	31
3.4.2. Control compartment and terminal compartment	31
3.4.3. Rectifier and inverter compartment	33
3.4.4. Grounding switch	34
3.4.5. Preparation for mechanical interlock at ground switch (option)	35
3.4.6. Rectifier	35
3.4.7. Protection IGCTs	35

3.4.8.	Inverter .....	36
3.4.9.	Filter .....	36
3.4.10.	Optional Braking Chopper .....	37
3.5.	Cooling system .....	40
3.5.1.	Fan configurations .....	40
3.5.2.	Type of fan.....	40
3.5.3.	Starting, stopping the cooling system .....	40
3.5.4.	AC redundant fans - operating principles.....	41
3.5.5.	EC redundant fans – operating principles .....	42
3.5.6.	Air flow overview (AC and EC fans) .....	43
3.5.7.	Monitoring the air pressure .....	44
3.5.8.	Adjustable parameters .....	44
3.6.	Cabinet design.....	45
3.7.	Door locking system.....	45
3.7.1.	Optional cabinets.....	46
3.8.	Arc resistant design (optional) .....	46
3.8.1.	Internal arc classification (IAC).....	46
3.8.2.	Associated protection requirement .....	46
3.9.	Space heaters.....	47
<b>4.</b>	<b>Control system .....</b>	<b>48</b>
4.1.	Overview .....	48
4.2.	Main components .....	49
4.2.1.	Local control panel.....	50
4.2.2.	AMC circuit board.....	51
4.3.	I/O interfaces .....	54
4.3.1.	IOEC I/O modules .....	54
4.3.2.	Serial communication interface (fieldbus) .....	58
4.3.3.	Pulse encoder interface NTAC (option).....	59
<b>5.</b>	<b>Transportation, storage and disposal .....</b>	<b>60</b>
5.1.	Safety.....	60
5.2.	Transport conditions .....	60
5.3.	Unpacking and inspection .....	60
5.4.	Lifting and transportation .....	61
5.4.1.	Lifting attachment types.....	62
5.4.2.	Lifting with the top lifting rails.....	63
5.4.3.	Lifting with rotating eyebolts (redundant fan unit) .....	65
5.4.4.	Reinstalling lifting attachments .....	65
5.4.5.	Sling configuration for top lifting rails .....	66
5.5.	Storage .....	67
5.5.1.	Storage conditions.....	67
5.5.2.	Storing the drive .....	67
5.5.3.	Storage and handling of spare parts .....	68
5.6.	Disposal of packaging materials and components .....	68
<b>6.</b>	<b>Mechanical installation.....</b>	<b>69</b>
6.1.	Safety.....	69
6.2.	Overview of installation work.....	69
6.3.	General notes on installation .....	69
6.3.1.	Dimensions and clearances .....	69
6.3.2.	Cabinet roof .....	69
6.3.3.	Fire protection.....	69
6.3.4.	Cable duct material.....	69
6.4.	Preparing the floor.....	70

PRODUCT	DOCUMENT KIND	DOCUMENT ID.	REV.	LANG.	PAGE
ACS1000A	User manual	3BHS213401 E01	N	en	4/160

6.5.	Fixing the cabinet to the floor .....	70
6.6.	Assembling and installing the air exhaust hood .....	71
6.7.	Installing the redundant fan unit .....	71
<b>7.</b>	<b>Electrical installation.....</b>	<b>76</b>
7.1.	Safety.....	76
7.2.	Overview of installation work.....	76
7.3.	Cable requirements .....	76
7.3.1.	Additional cable requirements for a UL certified drive.....	76
7.4.	Cable entries.....	77
7.4.1.	Cable entry with EMC plates .....	77
7.4.2.	Cable entry with type 1 sealing modules.....	78
7.4.3.	Cable entry with type 2 sealing modules .....	78
7.4.4.	Cable entry with cable glands.....	80
7.5.	Power cables, ground cables and equipotential bonding conductor .....	80
7.5.1.	Preparing the cable entry and the cables .....	80
7.5.2.	Connecting the cables .....	87
7.5.3.	Minimum creepage distance between cable and busbar.....	89
7.5.4.	Bolted connections .....	90
7.6.	Auxiliary power, control and serial communication cables .....	91
7.6.1.	Preparing the cable entry and the cables .....	91
7.6.2.	Connecting the cables .....	95
7.7.	Power supply cable for redundant fan unit .....	96
7.8.	Final checks.....	97
<b>8.</b>	<b>Commissioning.....</b>	<b>98</b>
8.1.	Overview .....	98
8.1.1.	Required qualification .....	98
8.1.2.	Commissioning procedure .....	98
8.1.3.	Commissioning checklist .....	98
8.1.4.	Customer assistance.....	98
8.1.5.	Customer acceptance .....	98
8.2.	Commissioning checklists .....	99
8.2.1.	Mechanical installation checklist.....	99
8.2.2.	Electrical installation checklist.....	99
8.2.3.	Main circuit breaker (MCB) checklist .....	99
8.2.4.	Input transformer checklist .....	99
8.2.6.	Insulation tests checklist.....	100
8.2.7.	Power supply checklist.....	100
8.2.8.	Miscellaneous checklist.....	100
8.2.5.	Motor checklist.....	100
<b>9.</b>	<b>Operation.....</b>	<b>101</b>
9.1.	Safety.....	101
9.2.	Overview .....	101
9.3.	Operating conditions .....	101
9.4.	Sound pressure level.....	101
9.5.	Local operator panel.....	102
9.6.	Status messages .....	103
9.6.1.	Start sequence of the drive.....	104
9.6.2.	Stop sequence of the drive.....	105
9.6.3.	Emergency off sequence of the drive .....	105
9.7.	Starting the drive .....	106
9.7.1.	Checks before starting the drive .....	106
9.7.2.	Starting the drive remotely .....	106

9.7.3.	Starting the drive locally .....	106
9.8.	Stopping the drive .....	109
9.9.	Emergency-off .....	110
9.9.1.	Initiating an emergency-off .....	110
9.9.2.	Starting the drive after an emergency-off .....	111
<b>10.</b>	<b>CDP control panel.....</b>	<b>112</b>
10.1.	Overview .....	112
10.2.	CDP control panel functions.....	113
10.3.	CDP control panel modes.....	113
10.3.1.	Identification mode .....	113
10.3.2.	Actual signals mode .....	114
10.3.3.	Parameters mode.....	121
10.3.4.	Functions mode .....	127
10.4.	Local and remote control .....	129
10.4.1.	Local control .....	129
10.4.2.	Remote control.....	130
10.5.	Operational commands.....	131
10.5.1.	Setting the direction of rotation .....	131
10.5.2.	Entering a reference value .....	132
<b>11.</b>	<b>Preventive and corrective maintenance .....</b>	<b>133</b>
11.1.	General information .....	133
11.1.1.	Required qualification .....	133
11.1.2.	Maintenance schedule.....	133
11.1.3.	Logbook.....	133
11.1.4.	Spare parts.....	133
11.2.	Identifying electrical equipment .....	134
11.2.1.	Device identification .....	134
11.2.2.	Cables and wires.....	134
11.2.3.	Understanding wiring diagrams .....	134
11.3.	Alarm / fault indications.....	135
11.3.1.	Messages .....	135
11.3.2.	Error message levels.....	135
11.3.3.	Fault handling.....	135
11.3.4.	Standard troubleshooting procedure .....	136
11.4.	Removing the CDP control panel .....	137
11.5.	LEDs and switches on circuit boards.....	138
11.5.1.	AMC circuit board .....	138
11.5.2.	IOEC I/O modules .....	139
11.6.	Corrective maintenance.....	140
11.6.1.	Safety .....	140
11.6.2.	De-energizing the drive locally .....	141
11.6.3.	Grounding .....	142
11.6.4.	Grounding switch is not released .....	143
11.6.5.	Checking the release conditions for the grounding switch .....	144
11.6.6.	Visual checks on the drive .....	145
11.6.7.	Cleaning the drive.....	145
11.6.8.	Checking wire and cable connections.....	146
11.6.9.	Cleaning and replacing filter mats.....	146
11.6.10.	Inspecting and replacing batteries.....	149
11.6.11.	Replacing the non-redundant fan .....	151
11.6.12.	Replacing a redundant fan .....	154

**FIGURES**

Figure 1 – Delivered items .....17

Figure 2 – Product warning label examples (label placement depends on the drive) .....20

Figure 3 – Drive system overview .....24

Figure 4 – MCB opening timing diagram.....25

Figure 5 – ACS1000 air-cooled .....27

Figure 6 – Block diagrams of an ACS1000A .....28

Figure 7 – Drive overview with power supplies .....29

Figure 8 – ACS1000 air-cooled topology .....31

Figure 9 – Control and terminal compartments .....32

Figure 10 – Rectifier compartment.....33

Figure 11 – Grounding switch.....34

Figure 12 – Example of a customer-specific trapped (1) key interlock system .....35

Figure 13 – Three-level voltage source inverter principle .....36

Figure 14 – Voltage and current waveforms at drive output.....36

Figure 15 – ACS1000A with braking chopper (1) .....37

Figure 16 – Principle diagram.....37

Figure 17 – Braking chopper design .....38

Figure 18 – Operating times of the AC fan units during continuous (A) drive operation and (B) Intermittent drive operation.....41

Figure 19 – Operating principles of redundant EC fans .....42

Figure 20 – Air flow: (1) non-redundant fan configuration .....43

Figure 21 – Air flow: redundant fan configuration .....43

Figure 22 – Air pressure switches .....44

Figure 23 – Door locks.....45

Figure 24 – IAC label example .....46

Figure 25 – Space heaters .....47

Figure 26 – Block diagram of control system with (A) customer interface, (B) control system, and (C) power electronics .....48

Figure 27 – Control compartment.....49

Figure 28 – Control compartment – I/O devices.....50

Figure 29 – AMC circuit board.....51

Figure 30 – Direct torque control.....52

Figure 31 – PID control mode .....53

Figure 32 – IOEC interfaces overview.....55

Figure 33 – IOEC module.....57

Figure 34 – IOEC module identification ..... 58

Figure 35 – NTAC-02 pulse encoder interface..... 59

Figure 36 – Lifting attachment types ..... 62

Figure 37 – Top lifting rails with (1) recommended lifting points ..... 63

Figure 38 – Mounting bolts and washers for top rail..... 64

Figure 39 – Sling configuration - standard case with top lifting rails ..... 66

Figure 40 – Leveling the drive ..... 70

Figure 41 – Fixing the cabinet to the floor..... 70

Figure 42 – Assembling and installing the air exhaust hood..... 71

Figure 43 – Redundant fan unit – Removing lifting rails (1) and fan access cover (2)..... 72

Figure 44 – Redundant fan unit – Installation..... 73

Figure 45 – Recommended sequence for attaching the sound absorbing panels on the right side of the fan unit ..... 74

Figure 46 – Recommended sequence for attaching the sound absorbing panels on the left side of the fan unit ..... 75

Figure 47 – EMC plate example..... 77

Figure 48 – EMC cushion..... 77

Figure 49 – Type 1 sealing modules (example)..... 78

Figure 50 – Type 2 sealing modules example ..... 79

Figure 51 – Cable entry with cable glands ..... 80

Figure 52 – Cable termination – busbar thickness is 5 mm ..... 81

Figure 53 – Preparing cables for EMC plates ..... 84

Figure 54 – Preparing power cables for sealing modules ..... 85

Figure 55 – Preparing power cables for cable glands ..... 86

Figure 56 – Power cable terminals..... 88

Figure 57 – Grounding the drive system ..... 89

Figure 58 – Bolted busbar connections ..... 90

Figure 59 – Cable entry ..... 91

Figure 60 – Frame with sealing modules..... 93

Figure 61 – Preparing control cables for sealing modules ..... 94

Figure 62 – Preparing control cables for cable glands ..... 94

Figure 63 – Shield grounding point for encoder cable..... 95

Figure 64 – Routing, connecting the cable of the redundant fan unit ..... 96

Figure 65 – Local operator panel ..... 102

Figure 66 – CDP control panel ..... 112

Figure 67 – Control panel - Actual signals mode..... 116

Figure 68 – Control panel - Parameters mode..... 123

Figure 69 – Control panel - Functions mode..... 127

Figure 70 – Device identification..... 134

Figure 71 – AMC circuit board ..... 138

Figure 72 – IOEC module ..... 139

Figure 73 – Location of I/O modules and fuses..... 143

Figure 74 – Filter panel (1) and filter mat (2) on rectifier and inverter compartment..... 148

Figure 75 – Control compartment – battery location ..... 149

Figure 76 – Control compartment - replacing the batteries..... 150

Figure 77 – Fan location, dimensions and weight ..... 151

Figure 78 – Fan - tools and devices ..... 151

Figure 79 – Replacing the non-redundant fan ..... 152

Figure 80 – Installing the non-redundant fan..... 153

Figure 81 – Redundant fans – location, dimensions, and weight ..... 154

Figure 82 – Redundant fans - tools and devices ..... 154

Figure 83 – Redundant fan unit – removing the panels ..... 155

Figure 84 – Redundant fan unit – Unplugging the power supply cable..... 156

Figure 85 – Redundant fan unit – removing the fixing bolts ..... 157

Figure 86 – Redundant fan unit – using a crane..... 158

Figure 87 – Redundant fan unit – using a platform ..... 158

## — TABLES

Table 1 – Standards.....	16
Table 2 – Braking ratings.....	39
Table 3 – ABB arc resistant classes.....	46
Table 4 – IOEC module configuration - analog inputs.....	55
Table 5 – IOEC module configuration - analog outputs.....	55
Table 7 – IOEC module configuration - digital inputs.....	56
Table 8 – 24 V internal voltage supply.....	56
Table 6 – IOEC module configuration - digital inputs.....	56
Table 9 – IOEC module identification.....	58
Table 10 – Lifting attachment specifications.....	65
Table 14 – Maximum number of cables per phase.....	81
Table 15 – Minimum creepage distance between cable and busbar.....	89
Table 16 – Parameter groups.....	121
Table 17 – Filter mat specifications.....	146

# 1. About this manual

## 1.1. Equipment covered by this manual

This manual covers a standard drive and provides generic information on the drive. The manual does not claim to cover all variations and details of the drive, nor to consider all eventualities that may arise during installation, commissioning, operation and maintenance of the drive.

If the drive is adapted to specific customer needs or applications, and handling, installation and operation of the drive are affected by these modifications, information on these modifications is provided in the appropriate documentation (eg, layout drawings, wiring diagrams, technical data, engineering notes).

If information is required beyond the instructions in this manual, refer the matter to ABB.

## 1.2. Structure of the user documentation

The documentation for a standard drive consists of this document and the following project-specific appendices.

NOTE – These appendices are NOT included in this document.

- **Appendix A - Additional manuals** provides manuals about additional equipment delivered with the drive (such as project-specific options such as pulse encoder or fieldbus interfaces), or information on modifications of the standard drive.
- **Appendix B - Technical data** contains the technical data sheets of the drive.
- **Appendix C - Mechanical drawings** provides the outline drawings of the drive. The drawings are generated according to the customer-specific project.
- **Appendix D - Wiring diagrams** contains the circuit diagrams with information on device identification, cross-reference and device identification conventions. The diagrams are generated according to the customer-specific project.  
“Setting of protective devices” is generated according to the customer-specific project.
- **Appendix E - Parts list** produced for each project and contains all information to identify a component.
- **Appendix F - Test reports and certificates** provides the test reports of the drive. Quality certificates, and codes and standards the drive complies with are added if necessary for the project.
- **Appendix G - Signal and parameter table** includes descriptions of actual signals, control and status words, and control parameters and their default settings.

PRODUCT	DOCUMENT KIND	DOCUMENT ID.	REV.	LANG.	PAGE
ACS1000A	User manual	3BHS213401 E01	N	en	11/160

## 1.3. Terms and abbreviations

The following table lists terms and abbreviations you should be familiar with when using this user manual. Some of the terms and abbreviations used in this user manual are unique to ABB and might differ from the normal usage.

Term/Abbreviation	Definition
ACS1000A	ACS1000 air-cooled drive
AMC circuit board	Application and Motor Controller The digital signal processor is the heart of the control system of the drive.
Cluster	A cluster is a synonym for a group of hardware modules of the drive control system.
CDP	Control and display panel Basic user interface for operating and monitoring the drive when local operating mode is selected.
DDCS	Distributed drive control system DDCS is an acronym for a serial communication protocol designed for data transfer via optical fibers.
Drive	Short form for ACS1000A drive
Drive system	The drive system includes all equipment used to convert electrical into mechanical power to give motion to the machine.
DriveBus	Communication link dedicated for ABB drives
DriveDebug	DriveDebug is part of ABB's DriveWare® software tools for drives using the DDCS communications protocol. DriveDebug runs on computers with Windows® operating systems. DriveDebug is a specialist's tool used to diagnose, tune and troubleshoot ABB drives.
DriveWindow	DriveWindow is a DriveWare® product. DriveWindow is a 32 bit Windows® application for commissioning and maintaining ABB drives equipped with optical communication links.
Equipment	Frequency converter and related equipment
EMC	Electromagnetic compatibility All measures to suppress electromagnetic disturbances caused by different electrical equipment in the same electromagnetic environment, and to strengthen the immunity of the equipment to such disturbances.
Ground	Earth
To ground	The conducting path (eg, conductor) between the electric equipment (eg, frequency converter) and the earth. The electric equipment is connected to the earth, eg, by a grounding set or a grounding switch.
INU	Inverter unit of the drive. The INU converts the DC voltage to the required AC motor voltage and frequency.
IOEC module	The IOEC module is an active input and output device for digital and analog signals.
Line voltage	RMS voltage of the main power supply of the drive
MCB	Main circuit breaker The MCB is a major protection device of the drive and is the main connection and disconnection point between the main power supply and the drive.
Molykote	Brand name for lubricants
NETA-21	Monitoring and diagnostics tool that allows access to the drive from any location in the world via a secure Internet connection.
PCB	Printed circuit board

Term/Abbreviation	Definition
PCC	Point of common coupling The PCC is the point in the electrical power supply system where the responsibility of the utility changes to the industrial customer. The utility is responsible to provide clean voltage and current with respect to harmonic distortion up to the PCC. The industrial customer is responsible not to distort voltage and current by its electrical systems.
PID controller	Proportional-integral-derivative controller Control loop feedback system for controlling process variables (eg, pressure, flow)
PE	Protective earth
PPCS	Power plate communication system PPCS is an acronym for a serial communication protocol designed for data transfer via optical fibers between AMC circuit board and INTerface circuit boards.
RTD	Resistance temperature detector or device The RTD is a temperature sensor where the change in electrical resistance is used to measure the temperature.
Supervisory signal	Indicates the operating condition of a circuit or device.
SW	Software
TC	Short form for terminal compartment of the drive
UPS	Uninterruptible power supply
Zero speed threshold	Used in the manual to indicate that the drive has reached the value “zero speed” that is set in a parameter. The value can be set in the range of 0 and maximum speed (the unit for the speed is rpm).

## 1.4. Related documents

### 1.4.1. Maintenance

Title	Document number
ACS1000A preventive maintenance schedule	3BHS855276 E01

### 1.4.2. Technical data

Title	Document number
Technical data from DriveSmart <sup>1</sup> (configuration software for medium voltage drives)	

<sup>1</sup> Configuration software for medium voltage drives

### 1.4.3. Schematics

Title	Document number
Layout drawing	Project-specific

### 1.4.4. Specifications and guidelines

Title	Document number
Retrofit guideline	3BHS301179 E01
Input circuit breaker engineering guideline	3BHS104785 E01
Main transformer specification	3BHS356582 E01
Induction motor specification	3BHS260163 E01
Power cable specification	3BHS189994 E01
Power cables engineering guideline	3BHS542290 E01
Auxiliary power and control cables guideline	3BHS813742 E01
Mechanical interlock	3BHS261596 E01
ACS1000 Mechanical door interlock system UL application note	3BHS261596 E03
Permission for working and permit to work for test work at test stations	3BHS817511 E30

### 1.4.5. Serial communication interfaces

Title	Document number
Ethernet - NETA-21 remote monitoring tool user manual	3AUA0000096939
Modbus - NMBA-01 installation and start-up guide	3AFY58919772
Profibus - NPBA-12 installation and start-up guide	3BFE64341588
DeviceNet - NDNA-02 installation and start-up guide	3AFY58919829

### 1.4.6. Encoder

Title	Document number
Installation and start-up guide for the pulse encoder module NTAC-0x	3AFY58919730

PRODUCT	DOCUMENT KIND	DOCUMENT ID.	REV.	LANG.	PAGE
ACS1000A	User manual	3BHS213401 E01	N	en	14/160

## 1.5. Target groups and required qualification

The drive presented in this manual is part of an industrial environment where voltages are present that contain a potential hazard of electric shock and / or burn. For this reason, only personnel who have a thorough knowledge of the drive and the industrial environment and have obtained the required qualification should handle, install, operate, or maintain the drive.

The manual addresses personnel who are responsible for unpacking, transportation, installation, operation and maintenance of the drive. The personnel must carry out the below listed tasks in a manner that does not cause physical harm or danger, and ensures the safe and reliable functioning of the drive.

**IMPORTANT!** Commissioning of the drive must only be performed by qualified and certified ABB personnel.

### 1.5.1. Handling

The personnel must be skilled and experienced in unpacking and transporting heavy equipment.

### 1.5.2. Mechanical installation

The personnel must be qualified to prepare the installation site according to the site and equipment requirements and to perform the installation accordingly.

### 1.5.3. Electrical installation

The personnel must have a sound knowledge of the relevant electrical codes and specifications covering low and medium voltage equipment, be experienced with electrical wiring principles and know the electrical symbols typically used in wiring diagrams.

### 1.5.4. Operation

The personnel include all persons who operate the drive from the local operator panel of the drive. The personnel must know the functions of the operator panel, be adequately trained for the drive, and know the driven process. Special knowledge of frequency converter technology is not required.

### 1.5.5. Maintenance

The personnel include all persons who

- Are qualified to carry out preventive and corrective maintenance on drive as described in this manual
- Are thoroughly familiar with the drive
- Have a sound knowledge of the relevant electrical codes and specifications covering low and medium voltage equipment
- Are able to assess the hazards associated with the energy sources of the drive and act correspondingly
- Know the safe shutdown and grounding procedures for the drive system

PRODUCT	DOCUMENT KIND	DOCUMENT ID.	REV.	LANG.	PAGE
ACS1000A	User manual	3BHS213401 E01	N	en	15/160

## 1.6. User's responsibilities

It is the responsibility of those in charge of the drive to ensure that each person involved in the installation, operation or maintenance of the drive has received the appropriate training and has thoroughly read and clearly understood the instructions in this manual and the relevant safety instructions.

## 1.7. Intended use of equipment

Those in charge of the drive must ensure that the drive is only used as specified in the contractual documents, operated under the conditions stipulated in the technical specifications and on the rating plate of the drive, and serviced in the intervals specified by ABB.

Use of the drive outside the scope of the specifications is not permitted.

Intended equipment use also implies that only spare parts recommended and approved by ABB must be used.

Unauthorized modifications and constructional changes of the drive are not permitted.

## 1.8. Quality certificates and applicable standards

The following certificates and conformity declarations are available with ABB:

- ISO 9001 and ISO 14001 certificates stating that ABB Switzerland Ltd has implemented and maintains a management system which fulfills the requirements of the normative standards
- EC declaration of conformity
- List of standards the drive complies with

**Table 1 – Standards**

Standard	Title
ANSI Z535.6	American national standard for product safety information in product manuals, instructions, and other collateral materials
ISO 3864-2	2004 (E) - Graphical symbols – Safety colors and safety signs – Part 2: Design principles for product safety labels
ISO 7010	2011 (E) - Graphical symbols - Safety colours and safety signs - Registered safety sign
EN 50110	European standard code for electrical work safety
ISO 13849-1	Safety of machinery - Safety-related parts of control systems - Part 1: General principles for design, section 6.2.6 Category 3
IEC 60204-1	Safety of machinery - Electrical equipment of machines - Part 1: General requirements
IEC 60721-3-1	Classification of environmental conditions: Classification of groups of environmental parameters and their severities; Storage
IEC 60721-3-2	Classification of environmental conditions - Part 3-2: Classification of groups of environmental parameters and their severities - Transportation and Handling
IEC 60721-3-3	Classification of environmental conditions - Part 3: Classification of groups of environmental parameters and their severities - Section 3: Stationary use at weather-protected location
IEC 62477-2	Safety requirements for power electronic converter systems and equipment – Part 2: Power electronic converters from 1 000 V AC or 1 500 V DC up to 36 kV AC or 54 kV DC
IEC 81346-1	Industrial systems, installations and equipment and industrial products - Structuring principles and reference designations - Part 1: Basic rules

PRODUCT	DOCUMENT KIND	DOCUMENT ID.	REV.	LANG.	PAGE
ACS1000A	User manual	3BHS213401 E01	N	en	16/160

## 1.9. Items covered by delivery

Delivery typically comprises the following items:

- Drive that is shipped in sea freight or airfreight packaging.
- Optional components and cabinets
- Set of door keys attached to lifting rail (1 in Figure 1)
- Set of door keys inside the drive
- Rating label (2 in Figure 1)
- Strain relief rails
- Air exhaust hood
- Redundant fan unit (option)
- Set of bolts, nuts and washers

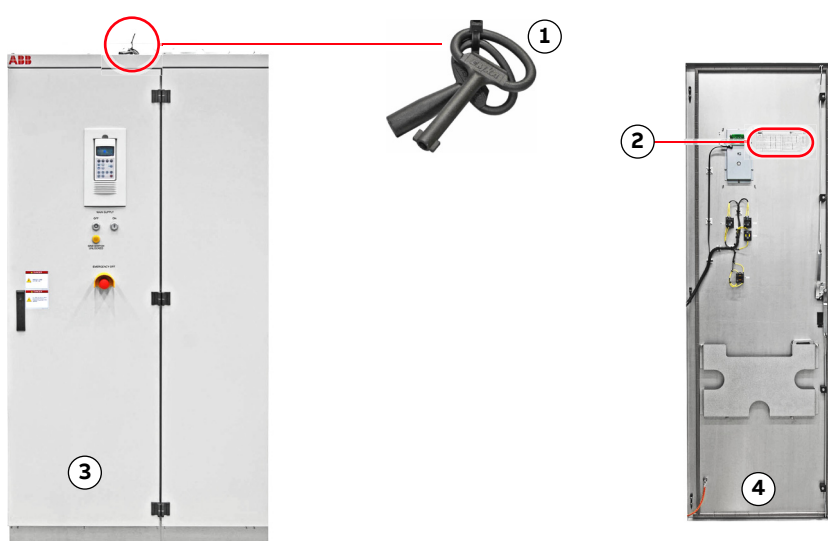

### Key

- (1) Door keys
- (2) Rating label
- (3) Control compartment door
- (4) Inside control compartment door

**Figure 1 – Delivered items**

For a complete list of the items in the delivery, see the shipping note.

## 1.10. Identifying the delivery

The drive and accessories are identified by the type code printed on the rating label.

The label provides information on the type of drive, the rated voltage, the frequency and the current of the main and the auxiliary power supply.

PRODUCT	DOCUMENT KIND	DOCUMENT ID.	REV.	LANG.	PAGE
ACS1000A	User manual	3BHS213401 E01	N	en	17/160



## 1.11. Document conventions

The document uses the following font formats and symbols. See also [2.1 Safety messages and safety signs in this document on page 19](#).

### Font formats

Convention	Description
✓	Prerequisite for a task
1.	Sequential procedural steps in a task
▶	Non-sequential procedural steps in a task or items in a list
•	
→	Instructions on how to avoid a safety hazard
1)	Numbered list
(1)	Explanation for callout keys in legend under an illustration or refers to a callout key in the main text, eg, "Lift fan (1)" or "Remove cover (1, Fig. 2) and..."
<i>Italic text</i>	Identifies software parameters, eg, <i>16.02 PARAMETER LOCK</i> .
<b>Bold text</b>	Depending on the context, indicates a safety hazard, the text that you type, a software or physical <b>button</b> , or a <b>link</b> to another part of the document
<u>Underlined text</u>	Identifies a hyperlink
<code>Fs{wmhw isrz</code>	Identifies software file names and file paths
<b>Cursor</b>	Represents blinking text on a screen

### Symbols

Symbol	Description
	Callout keys on an illustration
	These pictograms refer to the subject matter of the text.
	See <a href="#">2.1.2 Safety signs on page 19</a> .

## 2. Important safety information



Read this material carefully before working on or around the equipment. Failure to do so can result in serious Injury or DEATH! Keep for future reference.

### 2.1. Safety messages and safety signs in this document

This document uses ANSI Z535.6 signal words, ISO 7010 safety signs, and ISO 3864-2 colors to highlight safety-related information.

#### 2.1.1. Safety messages



This is the safety alert symbol. It is used to alert you to potential physical injury hazards. Obey all safety messages that follow this symbol to avoid possible injury or death.



**DANGER**

**Danger indicates a hazardous situation which, if not avoided, will result in death or serious injury.**



**WARNING**

**Warning indicates a hazardous situation which, if not avoided, could result in death or serious injury.**



**CAUTION**

**Caution indicates a hazardous situation which, if not avoided, could result in minor or moderate injury.**



**NOTICE**

**Notice is used to address practices not related to physical injury, but which can result in equipment damage.**

#### 2.1.2. Safety signs

Sign	Description
	Electrostatic discharge susceptible
	Hazardous voltage warning
	Arc flash warning

## 2.2. Product safety labels

Product safety labels on the equipment alert you to the hazards that can occur when you work on or operate the equipment.

- Always follow the instructions on the labels to avoid the hazard
- Keep the labels in a perfectly legible condition

For the location of the labels, see the label placement document for the drive.

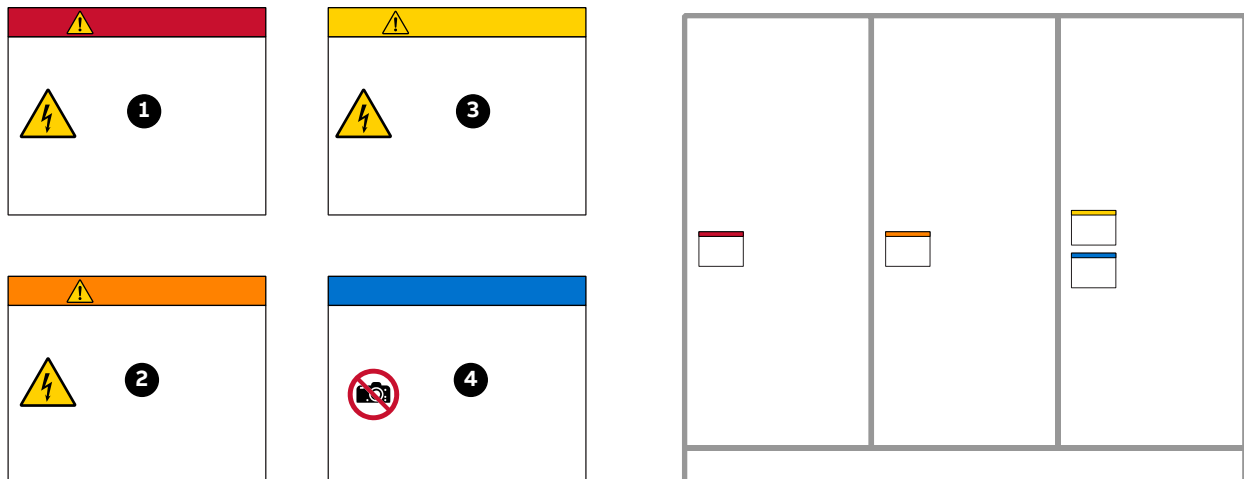

### Key

- (1) Danger label
- (2) Warning label
- (3) Caution label
- (4) Notice label

**Figure 2 – Product warning label examples (label placement depends on the drive)**

## 2.3. Electrical safety

The following electrical safety instructions are based on EN 50110.

### 2.3.1. General safety instructions

- **Minimize hazards**
- **Before energizing the drive:**
  - Before energizing the drive:
    - Remove all foreign objects from the drive
    - Fasten all internal and external covers securely
    - Close, lock, and/or bolt all doors
    - Move the release dial of the door safety switches into the locked position
  - Before working on the drive:
    - Turn off, lock out, and tag out the main and auxiliary power supplies to the drive
    - De-energize the drive
    - Ensure that the safety ground connections are in place
    - Ensure that the appropriate personal protective equipment (PPE) is available and used when required
    - Inform the involved personnel about the potential safety hazards
    - Wear hearing protection when a drive is running.

PRODUCT ACS1000A	DOCUMENT KIND User manual	DOCUMENT ID. 3BHS213401 E01	REV. N	LANG. en	PAGE 20/160
---------------------	------------------------------	--------------------------------	-----------	-------------	----------------

- **While working on the drive:**
  - DO NOT step on the roof
  - DO NOT install foreign objects on the roof
- **Before working simultaneously on the drive and on other drive system equipment:**
  - Observe the relevant safety codes and standards
  - Turn off all energy sources for the equipment
  - Ensure that all lockout and tagout devices are in place
  - Install barriers around and use appropriate covers on the equipment that is still energized
  - Inform the involved personnel about the potential safety hazards
- **In case of fire in the drive room:**
  - Observe the established rules and regulations for fire safety
  - Only allow firefighters with the appropriate PPE to enter the drive room

### 2.3.2. The seven steps that save lives

ABB's seven steps that save lives concept is a series of actions that must take place prior to commencing work on or near electrical installations.

- 1) Prepare for the work: do an on-site risk assessment or job hazard analysis that considers the limits of approach for shock and arc-flash.**
  - Be in possession of a clear work order to execute the work.
  - When required, the access or work permit is to be obtained by a person who is authorized for the specific electrical system.
  - Engage the person responsible for electrical equipment or system to review single-line diagrams, schematics, switching plans, etc.
  - Ensure the competence of workers.
  - Check for proper tools for the job.
  - Determine and select the proper arc-rated Personal Protective Equipment (PPE).
  - Decide of the appropriate work methods and initiate the Permit To Work (PTW) process. For an example "Permit to Work", see "Permission for working and permit to work for test work at test stations", 3BHS817511 E30
- 2) Clearly identify the work location and equipment.**
  - Use your senses (sight, hearing and smell) to identify problem areas.
  - Define the work area via barriers and barricading and label equipment.
  - Avoid distractions such as talking or texting on the phone.
- 3) Disconnect all sources of supply and secure against reconnection by applying Lockout/Tagout.**
  - If ABB is responsible for switching and it cannot be done remotely, then the person performing the switching must be properly trained and wearing the proper PPE identified in step 1.
  - The Person in Charge of Work (PICW) must ensure that switching is performed in the proper manner by witnessing it from a safe distance if present on site or by engaging the person responsible for switching to identify all isolation points.
  - Apply Lockout/Tagout (LOTO) to the energy isolation device and if multiple energy isolation devices are involved, then Group LOTO must be implemented with the PICW serving as the Group LOTO Leader.

PRODUCT ACS1000A	DOCUMENT KIND User manual	DOCUMENT ID. 3BHS213401 E01	REV. N	LANG. en	PAGE 21/160
---------------------	------------------------------	--------------------------------	-----------	-------------	----------------

**4) Verify the absence of operating voltage: always test before you touch!**

Only use properly rated and inspected voltage detection devices and wear proper PPE identified in step 1:

- Test voltage detection device
- Test for voltage
- Test voltage detection device

It is highly important that the voltage detection device is tested on a known voltage source such as a Proving Unit or by performing an internal self-test, according to the manufacturer's instructions, before and after testing for the absence of operating voltage.

**5) Carry out earthing and short-circuiting.**

- Close and lock the earthing switch if the electrical equipment is designed for this purpose or apply portable equipment for earthing and short-circuiting.

If this is carried out by the customer, then the PICW must ensure that this equipment is properly earthed as a part of the integration/verification and during step 7 when the PICW walks the PTW.

**6) Protect against adjacent live parts and take special precautions when close to bare conductors.**

- Determine minimum approach distances, apply screening or shrouding, and when applicable, padlock both cable and busbar shutters.
- If working within the restricted approach boundary or vicinity zone where inadvertent movement could cause contact with live parts, special precautions must be employed, such as the use of the properly rated insulated gloves and tools.

**7) Complete the permit to work and "Walk the Permit".**

- Check isolation points
- Verify that all circuits are isolated and secured
- Ensure all parties are integrated with the Lockout/Tagout
- Check the earths are properly applied
- Answer specific questions from the working group
- Ensure the work can proceed without danger
- Complete and verify the "Permit to Work"

PRODUCT	DOCUMENT KIND	DOCUMENT ID.	REV.	LANG.	PAGE
ACS1000A	User manual	3BHS213401 E01	N	en	22/160

### 2.3.3. Possible residual risks

Residual risks must be considered by the drive system integrator and/or plant owner when assessing the hazards of the equipment to personnel. The following risks can pose a hazard to drive system personnel

- **Electric power equipment generates electro-magnetic fields which can cause a hazard to people with metal implants and / or a pacemaker.**
- **Drive system components can move unintentionally when being commissioned, operated, or serviced due to:**
  - Operation of the equipment outside the scope of the specifications
  - Incorrectly assembled or installed equipment
  - Wrongly connected cables
  - External influence on, or damage of the equipment
  - Wrong parameter settings
  - Software errors
  - Faulty hardware
- **Hazardous touch voltages can be present on drive system components, which can be caused by:**
  - Operation of the equipment outside the scope of the specifications
  - External influence on, or damage of the equipment
  - Induced voltages by external equipment
  - Condensation on equipment components, or pollution
  - Faulty hardware
- **High temperatures, noise, particles, or gases can be emitted from drive system components caused by:**
  - Operation of the equipment outside the scope of the specifications
  - External influence on or damage of the equipment
  - Wrong parameter settings
  - Software errors
  - Faulty hardware
- **Hazardous substances can be emitted from drive system components, eg, due to incorrect disposal of components**

PRODUCT	DOCUMENT KIND	DOCUMENT ID.	REV.	LANG.	PAGE
ACS1000A	User manual	3BHS213401 E01	N	en	23/160

## 2.4. Main circuit breaker protection device

The main circuit breaker (MCB) is a major protection device of the drive. If a serious fault occurs in the drive, the MCB must disconnect the main power supply to the drive immediately. The main power supply must be disconnected without delay on an open or trip command from the drive to prevent hazard to the personnel and further damage to the equipment. The MCB is located on the primary side of the converter transformer.

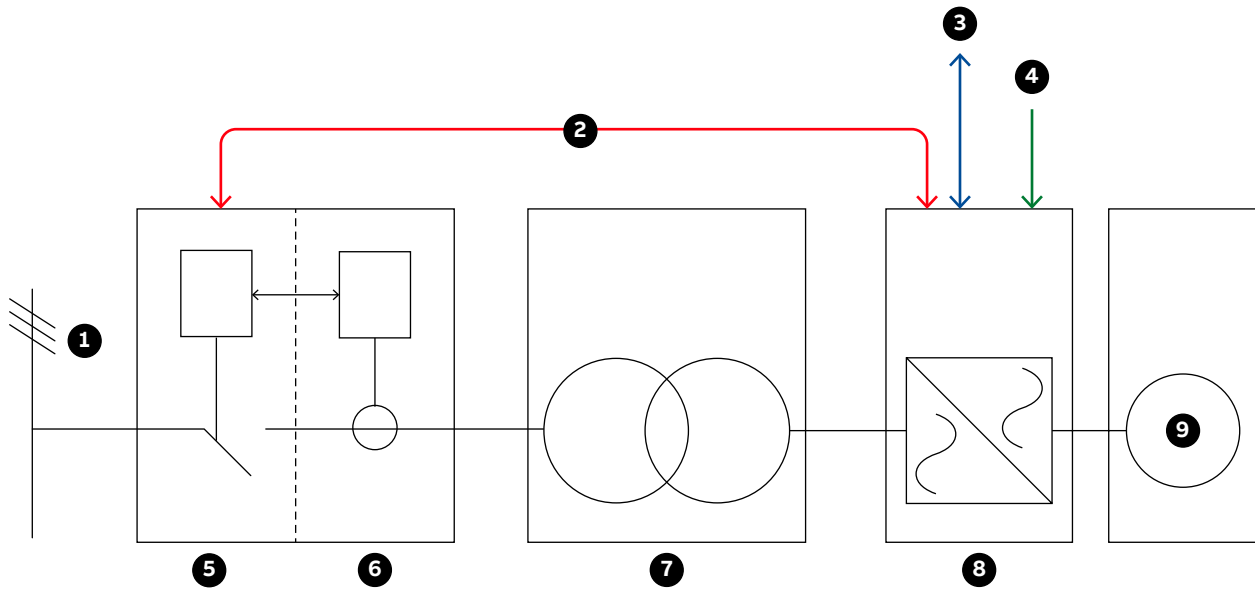

### Key

- (1) Main power supply
- (2) MCB control interface
- (3) Higher-level control system
- (4) Local MCB control
- (5) MCB
- (6) Protection relay
- (7) Converter transformer
- (8) Drive
- (9) Motor

**Figure 3 – Drive system overview**

NOTE – MCBs and protection relays are not included in the drive supply.

### Typical MCBs devices

- Vacuum circuit breakers
- SF6 circuit breakers
- Fused contactors or motor control centers

### Dedicated protection relay

- Transformer or drive primary cable protection (DTL)
- Transformer protection (if applicable)
- Transformer secondary cable protection (if applicable)
- Backing up the drive protection

PRODUCT	DOCUMENT KIND	DOCUMENT ID.	REV.	LANG.	PAGE
ACS1000A	User manual	3BHS213401 E01	N	en	24/160

### 2.4.1. Safety and protection requirements

For safety and protection reasons, the MCB must meet the stipulated minimum requirements of the specifications of ABB MV Drives. It is the system integrator's responsibility to ensure that the minimum requirements are met. The minimum requirements for the MCB are stated in this note and in the respective MCB specifications, which are available for each medium voltage drive from ABB.

The safety requirements for the drive are based on the following standards:

- ISO 13849-1
- IEC 60204-1

### 2.4.2. Minimum requirements for MCB and MCB control

The following safety requirements are also in the MCB specifications for the drive:

- The MCB open and / or trip command has to be wired directly from the drive to the MCB.
  - It is not permitted to wire the trip command through any PLC or DCS system if it is not certified to meet SIL three-level requirements and to fulfill the timing requirements outlined below.
  - Opening of the MCB by the drive must be possible at any time. It is not permitted to interrupt the open and / or trip command, eg, by a local-remote switch in the MCB.
- When the MCB is in service position, the drive must have exclusive control of closing the MCB. Local closing of the MCB is not permitted.
- The maximum opening time of the MCB must never exceed the product- or project-specific maximum time defined in the MCB specifications.

Typical maximum values for the drive are defined as follows:

- **Maximum protection trip time: 120 ms**  
The maximum protection trip time is the maximum allowed breaking time (open and arcing) of the breaking device after the open command has been initiated to prevent further damage to the drive, such as diode failures.
- **Maximum safety trip time: 250 ms**  
The maximum safety trip time is the maximum allowed time to ensure safe disconnection of the main power supply to prevent any hazard to personnel.

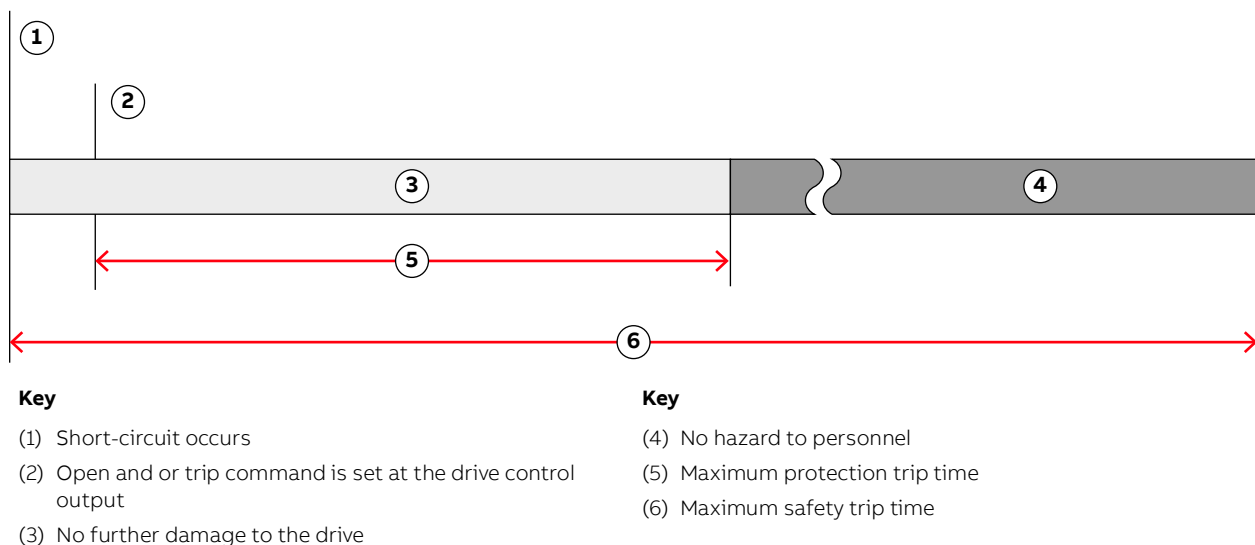

**Figure 4 – MCB opening timing diagram**

In order to meet the stipulated safety requirements, ABB recommends one of the following:

- MCB is equipped with 2 independent opening coils
- MCB is equipped with an opening coil and an undervoltage coil for monitoring of the control voltage
- Upstream protection coordination scheme is provided which uses the “breaker failure” (ANSI 50BF) signal to automatically trip the upstream breaker, in case the MCB does not open.

**IMPORTANT!** The upstream breaker must open within the maximum safety trip time after a failure has occurred.

## 2.5. Maintenance recommendation

The MCB trip circuits should be checked annually.

PRODUCT	DOCUMENT KIND	DOCUMENT ID.	REV.	LANG.	PAGE
ACS1000A	User manual	3BHS213401 E01	N	en	26/160

## 3. Power electronics and cabinet features

### 3.1. Overview

The ACS1000 air-cooled drive is a general-purpose frequency converter for the control of standard induction motors.

For information on the power and voltage range of the drive, see the Technical specifications and the rating plate of the drive.

The following sections provide an overview of:

- Drive topology and main features
- Available main and auxiliary power configurations
- Power electronic components of the drive
- Cooling system
- Cabinet features such as the grounding switch and the electro-mechanical door interlock



Figure 5 – ACS1000 air-cooled

PRODUCT	DOCUMENT KIND	DOCUMENT ID.	REV.	LANG.	PAGE
ACS1000A	User manual	3BHS213401 E01	N	en	27/160

## 3.2. Drive topology

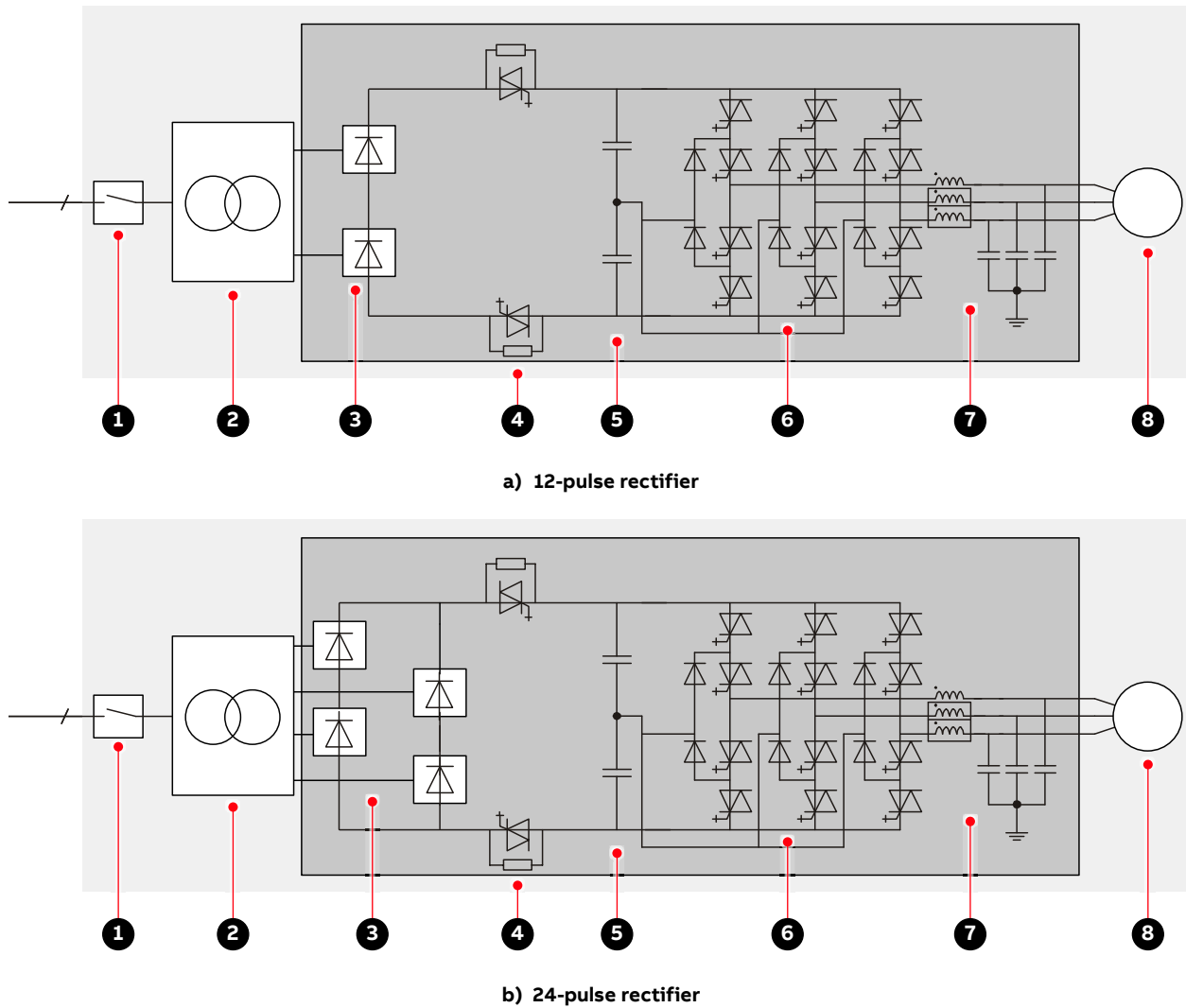

### Key

- (1) Medium voltage switchgear, including main circuit breaker and transformer protection
- (2) Transformer
- (3) Rectifier
- (4) Protection IGCTs
- (5) DC link
- (6) Inverter
- (7) Filter
- (8) Motor

**Figure 6 – Block diagrams of an ACS1000A**

The drive system consists of the following main components:

- **Main circuit breaker (MCB):** see [2.4 Main circuit breaker protection device on page 24](#).
- **Transformer:** see the Transformer specification.
- **Drive**
- **Asynchronous motor:** see the motor specification.

PRODUCT	DOCUMENT KIND	DOCUMENT ID.	REV.	LANG.	PAGE
ACS1000A	User manual	3BHS213401 E01	N	en	28/160

### 3.3. Power supply configurations

The drive requires 2 independent power supplies:

- Main power supply for the power electronic components
- Auxiliary power supply for the control and cooling system

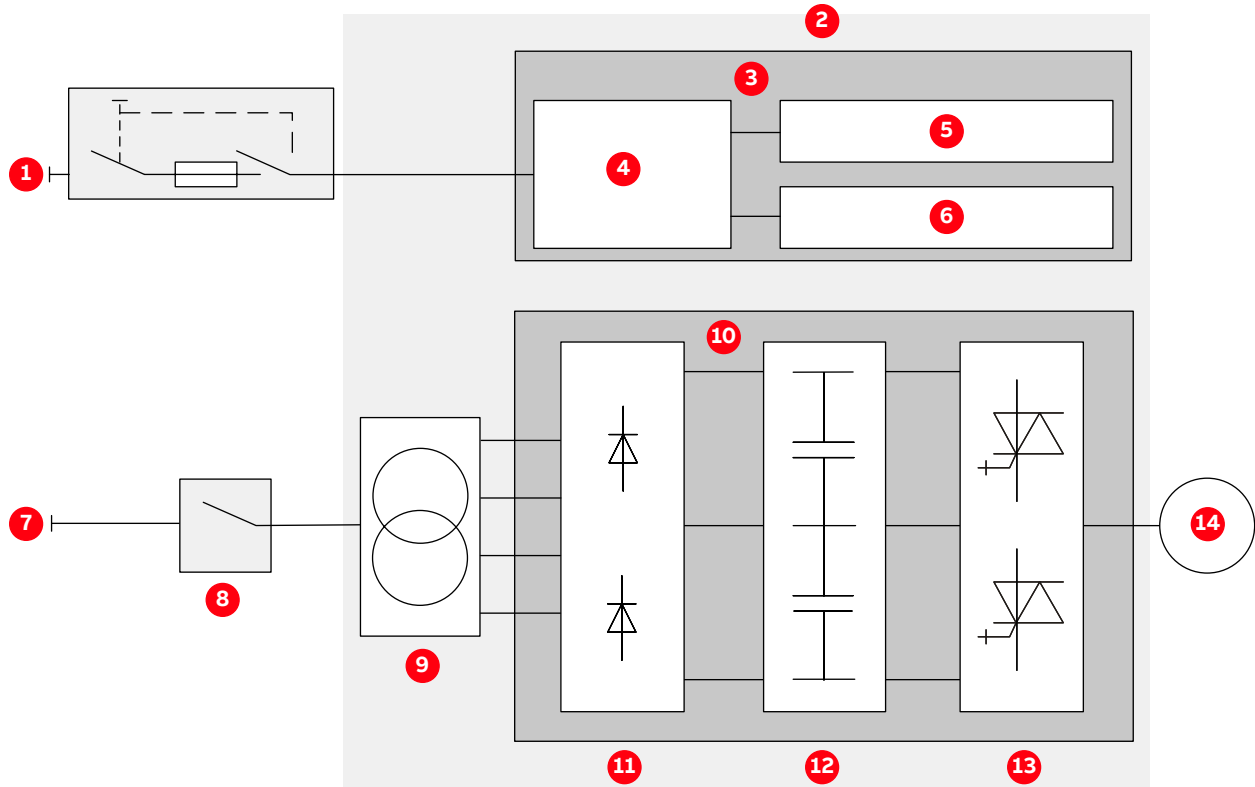

#### Key

- (1) Auxiliary power supply
- (2) ACS1000A
- (3) Control and cooling system
- (4) Auxiliary power distribution
- (5) Cooling system
- (6) Control system
- (7) Main power supply
- (8) MCB
- (9) Transformer
- (10) Power electronic components
- (11) Rectifier
- (12) DC link
- (13) Inverter
- (14) Motor

**Figure 7 – Drive overview with power supplies**

#### 3.3.1. Main power supply configurations

The drive is connected to the main power supply via a three-winding oil or dry-type transformer.

PRODUCT	DOCUMENT KIND	DOCUMENT ID.	REV.	LANG.	PAGE
ACS1000A	User manual	3BHS213401 E01	N	en	29/160

### 3.3.2. Auxiliary power supply configurations

The total auxiliary power demand of the drive includes:

- Auxiliary power for the cooling system
- Auxiliary power for the control hardware and the gate units which are used to trigger the power semiconductors

The total auxiliary power can be fed to the drive in the following ways:

- Through a common power supply
  - The total auxiliary power is supplied to the drive by a three-phase AC power supply.
  - If the power supply is interrupted, drive internal batteries provide a backup for the control system, thus enabling the drive to ride-through and/or to perform a controlled shutdown.
- Through separate power supplies
  - The auxiliary power is supplied to the drive by a three-phase AC power supply and by an UPS to a separate one-phase AC or DC input.
  - Feeding the control power separately by an UPS has the advantage that the main control hardware will remain energized, the full ride-through capabilities of the drive can be used, and the communication to a higher-level control system will not be lost in the event of an auxiliary power outage.

**IMPORTANT!** The power feed for the auxiliary supply must be protected with a suitable circuit protection rated for the inrush current.

For more information on the auxiliary power interface of the drive, see “Appendix D - Wiring diagrams”. For information on the rated voltage(s) and current(s), see the rating plate of the drive.

PRODUCT	DOCUMENT KIND	DOCUMENT ID.	REV.	LANG.	PAGE
ACS1000A	User manual	3BHS213401 E01	N	en	30/160

## 3.4. Drive topology

This section describes the main design features and introduces the major power electronics components of a typical drive.

### 3.4.1. Overview

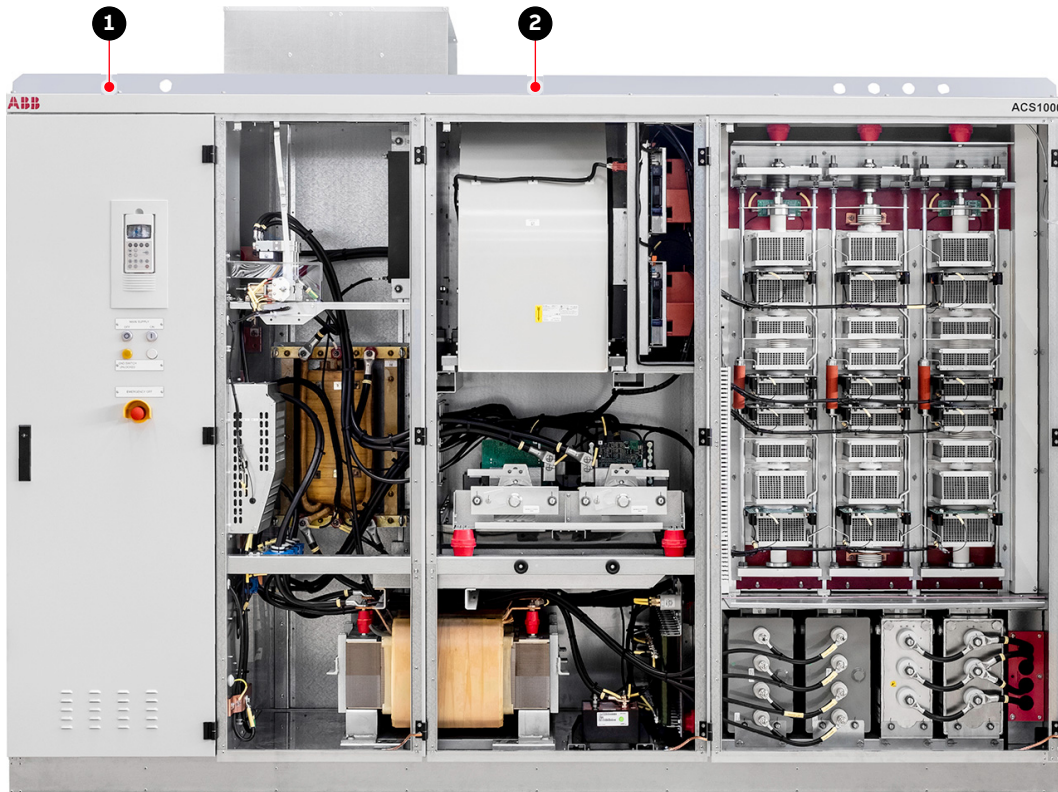

#### Key

- (1) Control compartment and terminal compartment
- (2) Rectifier and inverter compartment

**Figure 8 – ACS1000 air-cooled topology**

### 3.4.2. Control compartment and terminal compartment

The left compartment of the drive comprises:

- **Control compartment at the front (1, Figure 9):** contains the hardware of the control system of the drive.  
For more information on the control hardware, see [4 Control system on page 48](#).
- **Terminal compartment at the back (1, Figure 9)** contains the busbars for the feeder and motor cables, the ground cable and the cable screens. A hinged bolted partition separates the terminal compartment from the control compartment.  
For more information on cable entry and cable connection, see [7 Electrical installation on page 76](#).

PRODUCT	DOCUMENT KIND	DOCUMENT ID.	REV.	LANG.	PAGE
ACS1000A	User manual	3BHS213401 E01	N	en	31/160

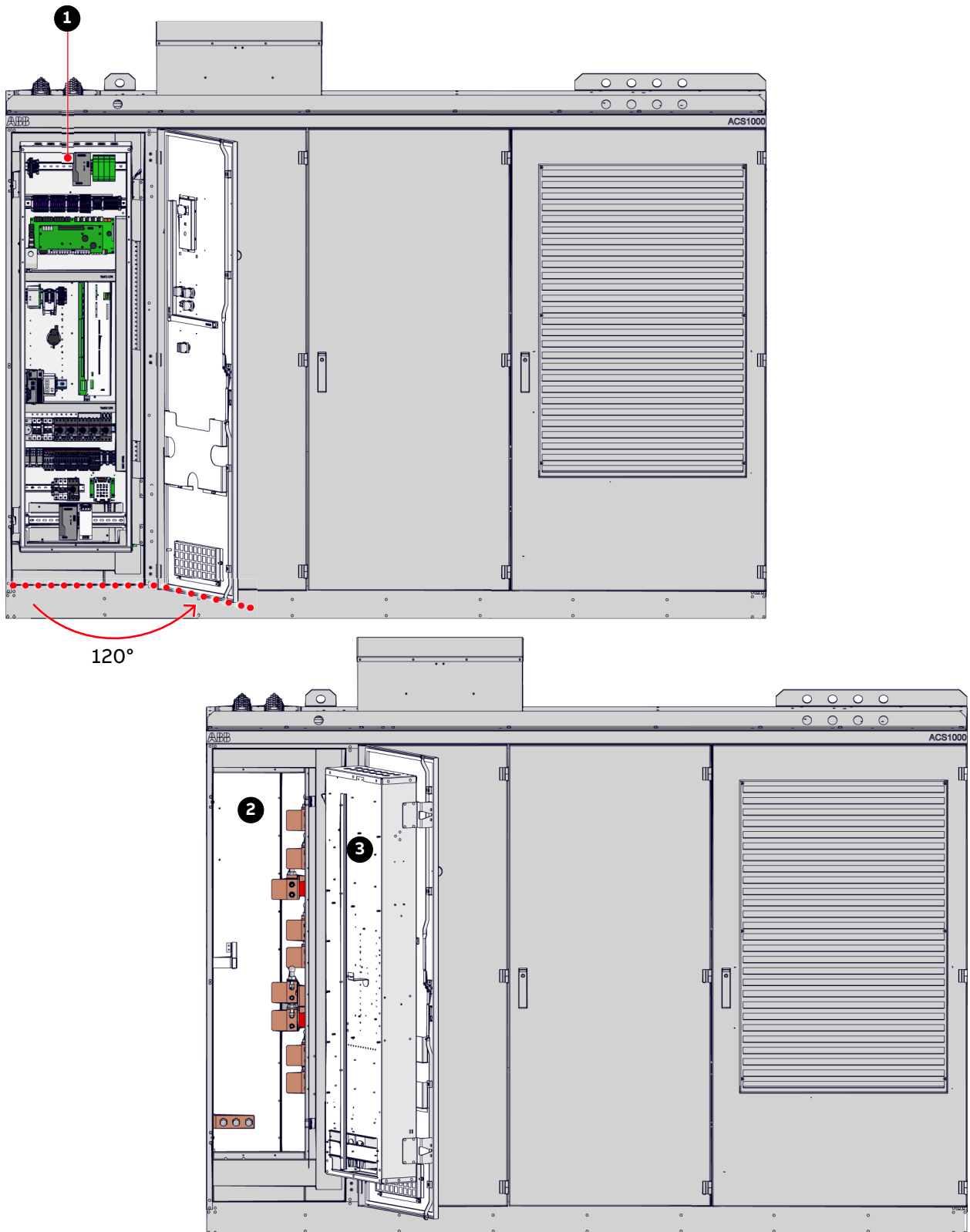

**Key**

- (1) Control compartment
- (2) Terminal compartment
- (3) Swing frame

**Figure 9 – Control and terminal compartments**

PRODUCT	DOCUMENT KIND	DOCUMENT ID.	REV.	LANG.	PAGE
ACS1000A	User manual	3BHS213401 E01	N	en	32/160

### 3.4.3. Rectifier and inverter compartment

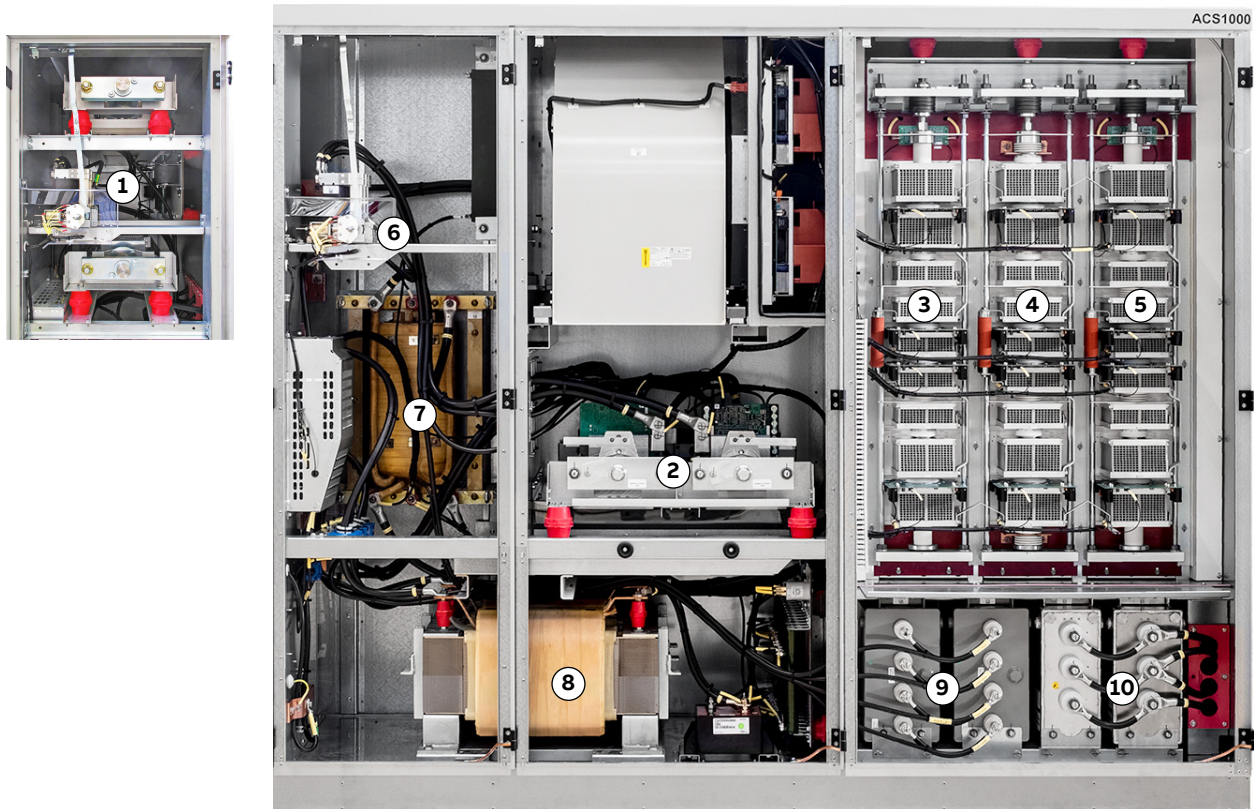

#### Key

- (1) Second 12-pulse rectifier
- (2) 12-pulse rectifier with protection IGCTs
- (3) Inverter phase U
- (4) Inverter phase V
- (5) Inverter phase W
- (6) Grounding switch
- (7) Common mode choke (option)
- (8) Filter choke
- (9) Filter capacitors
- (10) DC-link capacitors

**Figure 10 – Rectifier compartment**

PRODUCT	DOCUMENT KIND	DOCUMENT ID.	REV.	LANG.	PAGE
ACS1000A	User manual	3BHS213401 E01	N	en	33/160

### 3.4.4. Grounding switch

The grounding switch is a safety device that enables safe access to the medium voltage compartments of the drive.

When the switch is in position grounded, the DC link of the drive is connected to the PE ground busbar.

The grounding switch is electro-mechanically interlocked with a discharge monitoring circuit that prevents closing of the switch while the DC link capacitors are still charged.

Grounding the drive is only possible after the main power supply has been disconnected, and the DC link has discharged. When the voltage is below 50 V (DC), the lamp grounding switch unlocked (1, Figure 11) on the door of the control compartment lights up, and the grounding switch can be turned to position grounded (2, Figure 11).

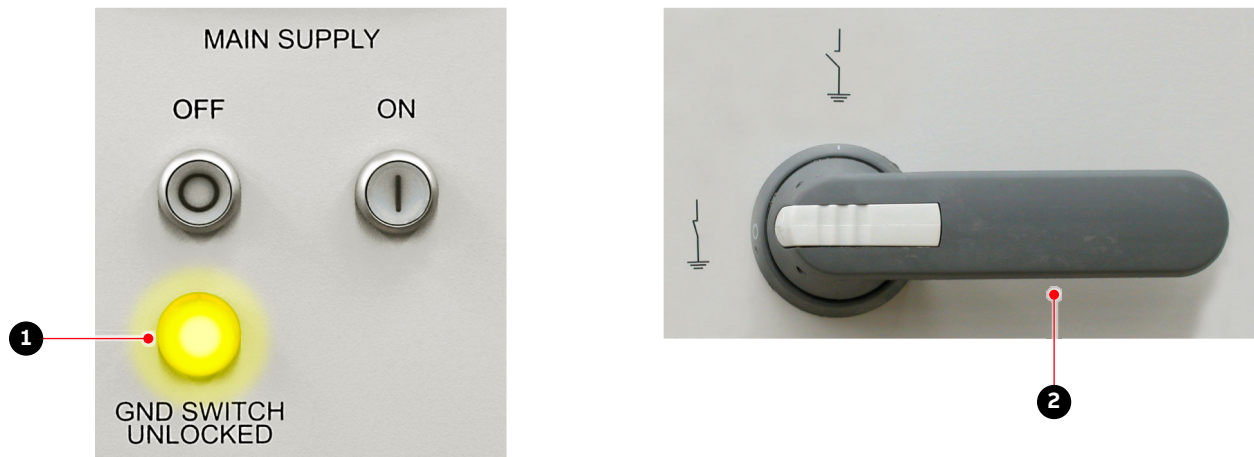

**Key**

- (1) Grounding switch unlocked lamp is on
- (2) Grounding switch in grounded position

**Figure 11 – Grounding switch**

When the grounding switch is in position grounded, the doors of the medium voltage compartments are released, and the doors can be opened.

### 3.4.5. Preparation for mechanical interlock at ground switch (option)

In a mechanical door interlock system (1, Figure 12) the equipment can only be accessed in a predefined and safe sequence. A drive with this option is prepared for the installation, but the key interlocks are not supplied.

**IMPORTANT!** For UL certified drives, mechanical door interlocks are mandatory and the key locks are factory-installed. Additional parts for the upstream MCB are included with the delivery and must be installed according to “ACS1000 Mechanical door interlock system UL application note”, 3BHS261596 E03.



**Figure 12 – Example of a customer-specific trapped (1) key interlock system**

For information on the installation and type of key interlocks that are supported, see “Mechanical interlock”, 3BHS261596 E01.

### 3.4.6. Rectifier

The diode rectifier converts the AC voltage of the main power supply and connects its output to the minus, neutral point, and plus side of the DC link.

Depending on the harmonics requirements for the main power supply, the drive is equipped with a 12-pulse or a 24-pulse rectifier.

### 3.4.7. Protection IGCTs

The drive features a fuseless protection design. The IGCTs are placed between the rectifier and the DC link. If necessary, the IGCTs directly isolate the inverter from the main power supply.

PRODUCT	DOCUMENT KIND	DOCUMENT ID.	REV.	LANG.	PAGE
ACS1000A	User manual	3BHS213401 E01	N	en	35/160

### 3.4.8. Inverter

The compartment contains the inverter and the DC-link capacitors and filter capacitors.

The inverter converts the DC voltage to the required AC motor voltage and frequency.

Each phase of the three-phase inverter consists of a combination of four IGCTs and two NP diodes for three-level switching operation. The output is switched between positive DC voltage, neutral point (NP) and negative DC voltage. Hence, the drive can control the output voltage and the frequency continuously from zero to maximum using direct torque control.

For more information, see [4.2.2.4 Direct torque control on page 52](#).

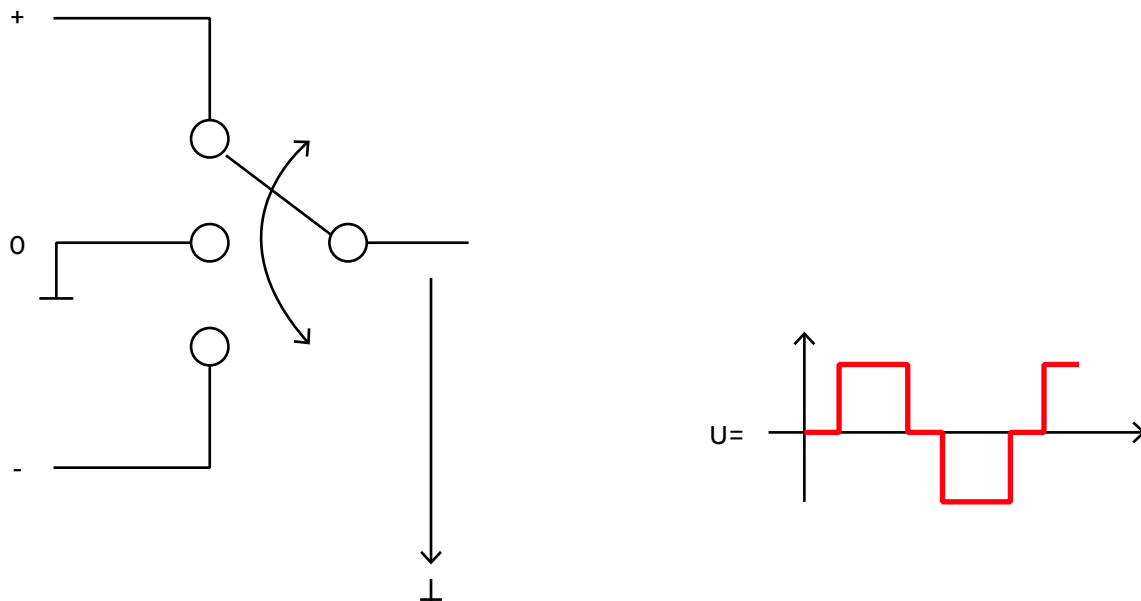

**Figure 13 – Three-level voltage source inverter principle**

### 3.4.9. Filter

The filter at the drive output reduces the harmonic content of the motor voltage and generates a nearly sinusoidal motor-friendly voltage waveform. The filter also eliminates all high dv/dt effects. Therefore, standard motors can be used, and voltage reflections in the motor cables are eliminated.

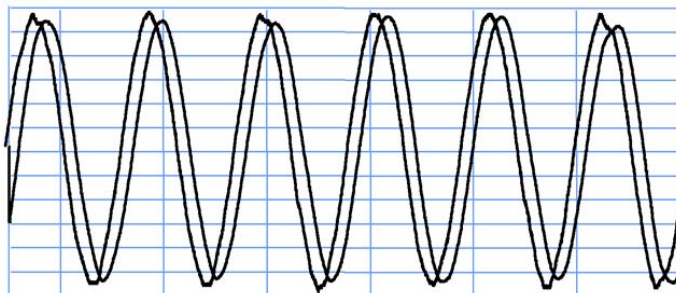

Output voltage: 4.16 kV

Output frequency: 60 Hz

**Figure 14 – Voltage and current waveforms at drive output**

### 3.4.10. Optional Braking Chopper

The optional braking chopper uses resistor braking to provide motor braking and shorter deceleration times, eg, for:

- Reduction of coasting down time, eg, for conveyor belts, fans, and pumps
- Emergency stops

The braking chopper cabinet connects to the right side of the drive as well as to the braking resistors, which are external to the ACS1000A and not part of the product scope.

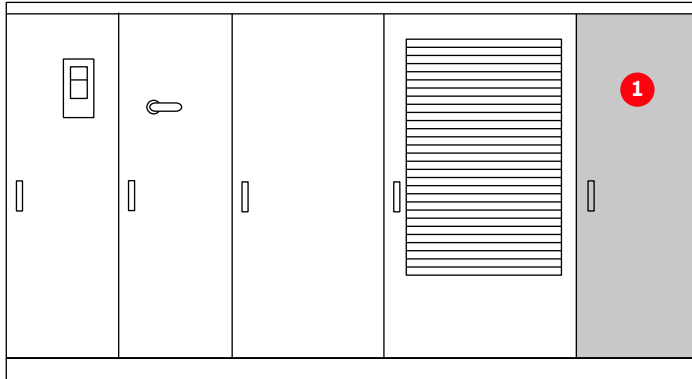

**Figure 15 – ACS1000A with braking chopper (1)**

The braking chopper is controlled and monitored by the ACS1000A.

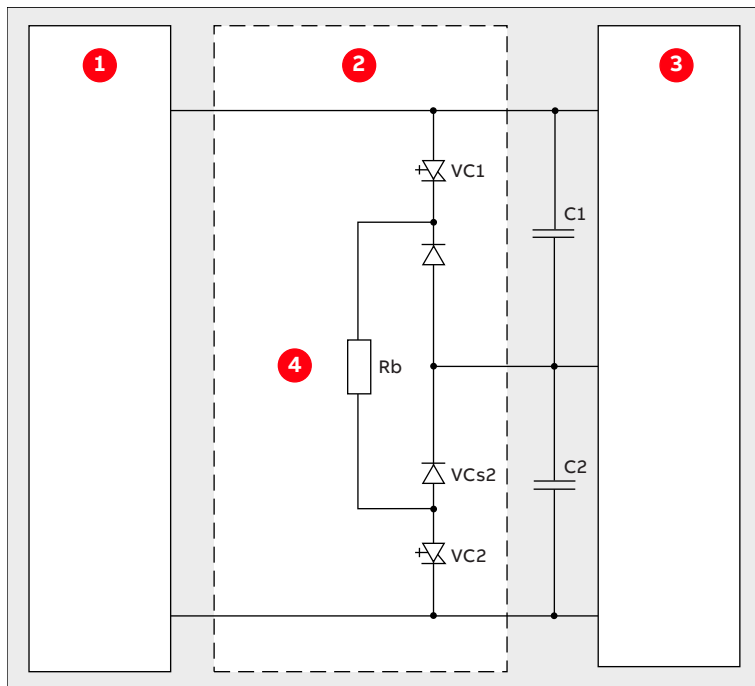

**Key**

- (1) Rectifier
- (2) Braking chopping
- (3) Inverter
- (4) Braking resistor

**Figure 16 – Principle diagram**

PRODUCT	DOCUMENT KIND	DOCUMENT ID.	REV.	LANG.	PAGE
ACS1000A	User manual	3BHS213401 E01	N	en	37/160

### 3.4.10.1. Control principle

If the DC-link voltage rises above a preset limit, the control system of the ACS1000A automatically activates the braking chopper. A rise of the DC-link voltage can be caused by a machine, feeding into the DC link or by an increase of the voltage in the rectifier of the ACS1000A.

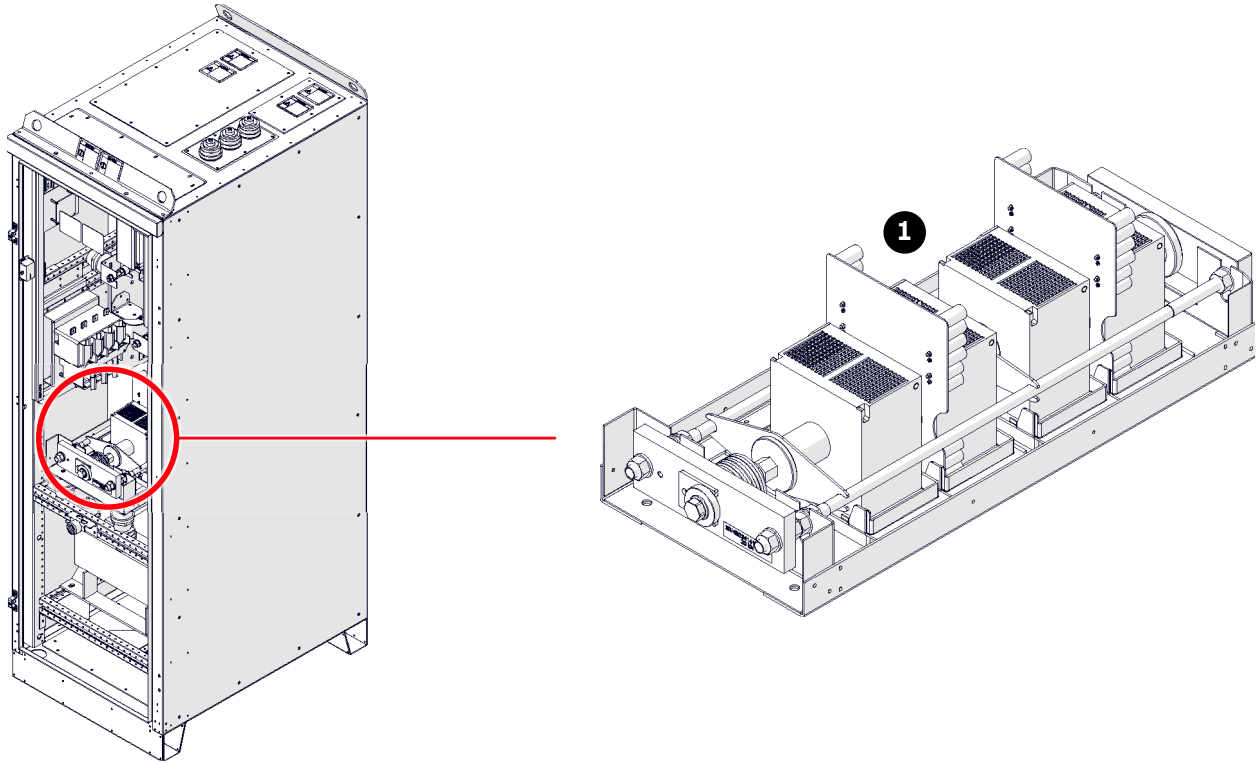

#### Key

(1) Semiconductor stack

**Figure 17 – Braking chopper design**

### 3.4.10.2. Monitoring and protective functions

#### Current monitoring

Input currents of the braking chopper are monitored for overcurrent and imbalance in order to detect any defective component in the circuit. The current can become imbalanced if one of the IGCTs conducts a current permanently or if an IGCT fails to be switched on.

If a short-circuit or an imbalance is detected in the braking chopper, the drive is shut down.

#### Thermal protection

The braking chopper and the braking resistors are monitored for over-temperature by the ACS1000A.

In addition, an external thermal protection device can be connected to a digital input. As soon as the temperature of the braking resistors exceeds the response threshold of the external thermal protection device, the operation of the braking chopper is disabled and an alarm message is displayed on the control panel of the ACS1000A. Braking is then only possible when the temperature falls below the threshold.

PRODUCT	DOCUMENT KIND	DOCUMENT ID.	REV.	LANG.	PAGE
ACS1000A	User manual	3BHS213401 E01	N	en	38/160

### 3.4.10.3. External cooling for braking resistors

A digital output and a digital input can be used to control and monitor an external cooling fan or pump for the braking resistors.

### 3.4.10.4. Braking chopper ratings

The maximum braking power is limited to 60% of the nominal power of the ACS1000A and must not be greater than 2.5 MW (Table 2).

The relation between maximum braking energy ( $E_{\text{brake max}}$ ) and maximum chopper braking power ( $P_{\text{chopper max}}$ ) is as follows:

$$E_{\text{brake max}}(\text{MWs}) = P_{\text{chopper(max)}}(\text{MW}) \times 30 \text{ sec} \quad [1]$$

After a braking period of 30 s with maximum braking power (2.5 MW), a cooling time of one hour is required. If two braking sequences of 30 s are necessary within an hour, the maximum braking power has to be reduced to 50% of the maximum possible braking power.

**Table 2 – Braking ratings**

Type	ACS1000A		Braking chopper	
	Maximum DC-link voltage (V)	Maximum braking power (MW)	Maximum braking power (MW)	Maximum braking energy (MWs)
ACS1012-A1	4200	0.426	2.5	75
ACS 1013-A1	6000	0.426		
ACS 1014-A1	7270	0.426		
ACS1012-A2	4200	0.672	2.5	75
ACS 1013-A2	6000	0.672		
ACS 1014-A2	7270	0.840		
ACS1012-A3	4200	0.960	2.5	75
ACS 1013-A3	6000	1.080		
ACS 1014-A3	7270	0.960		
ACS1012-W1	4200	1.350	2.5	75
ACS 1013-W1	6000	1.500		
ACS 1014-W1	7270	1.350		
ACS1012-W2	4200	1.680	2.5	75
ACS 1013-W2	6000	2.130		
ACS 1014-W2	7270	2.130		
ACS 1013-W3	6000	2.500	2.5	75
ACS 1014-W3	7270	2.500		

### 3.4.10.5. Cabinet dimensions and weight

Length	644 mm
Depth	902 mm
Width	2002 (2070 including lifting eyes)
Height	460 kg

### 3.4.10.6. Braking resistor cables

Cable type	Shielded
Minimum cross sectional area	70 mm <sup>2</sup>
Voltage rating	Half of maximum converter DC-link voltage If a multi-core cable is used, the full DC-link voltage must be taken into consideration.
Maximum length	50 m

The configuration and dimensions of the braking resistors depend on the specific application. For information, see the “Dimensioning of braking resistors” application note.

## 3.5. Cooling system

### 3.5.1. Fan configurations

The cooling system of the drive is equipped with one of the following fan configurations:

- **Non-redundant:** The fan (1 in Figure 20) is installed inside the cabinet.
- **Redundant:** Fan 1 and fan 2 (1 and 2 in Figure 21) are installed on the roof. This configuration enables continuous operation of the drive if a fan fails.

### 3.5.2. Type of fan

The drive is equipped with one of the following types:

- **AC fans:** The AC fans are turned on and off with digital signals which switch contactors to connect or disconnect the 3-phase auxiliary power. The AC fan speed is not controlled.
- **EC fans:** The electronically commutated (EC) fans are controlled via an analog signal from the drive based on the inverter current. The EC fan speed is controlled depending on the required cooling.

### 3.5.3. Starting, stopping the cooling system

The drive switches on the cooling system when the main circuit breaker (MCB) closes. When the MCB opens, the cooling system switches off after a delay. The delay corresponds to the discharging time of the drive and takes up to 5 minutes.

### 3.5.4. AC redundant fans - operating principles

Default settings:

- Cycle time during which AC fan 1 and AC fan 2 run alternately: 10 h
- Operating time of AC fan 1: 6 h
- Operating time of AC fan 2: 4 h

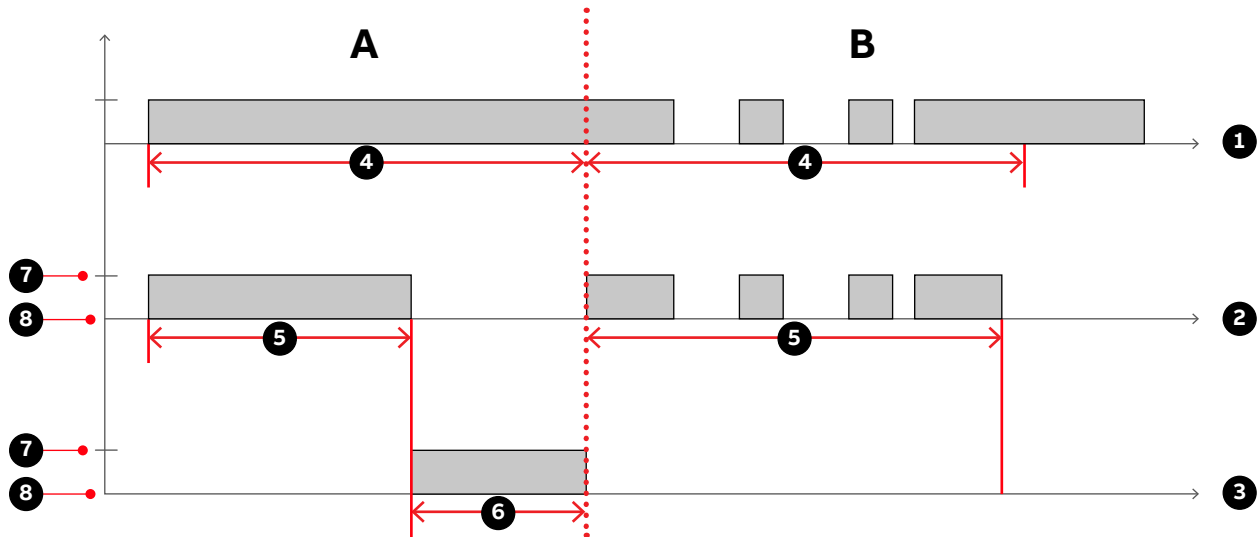

#### Key

- (1) Cycle time
- (2) Fan 1
- (3) Fan 2
- (4) 10 hours
- (5) 6 hours
- (6) 4 hours
- (7) On
- (8) Off

**Figure 18 – Operating times of the AC fan units during continuous (A) drive operation and (B) Intermittent drive operation**

When the drive operates continuously, AC fan 1 switches off after six hours and fan 2 switches on for four hours.

When the drive operates intermittently, the AC fan that is due for operation is switched on and off in the same pattern as the drive until the programmed operating time has elapsed.

If one AC fan fails, the second AC fan switches on and runs continuously.

### 3.5.5. EC redundant fans – operating principles

When no EC fan failure exists, all EC fans are turned on and are running at a lower speed (typically the minimum speed). When one EC fan fails, the second EC fan will speed up to ensure the required cooling.

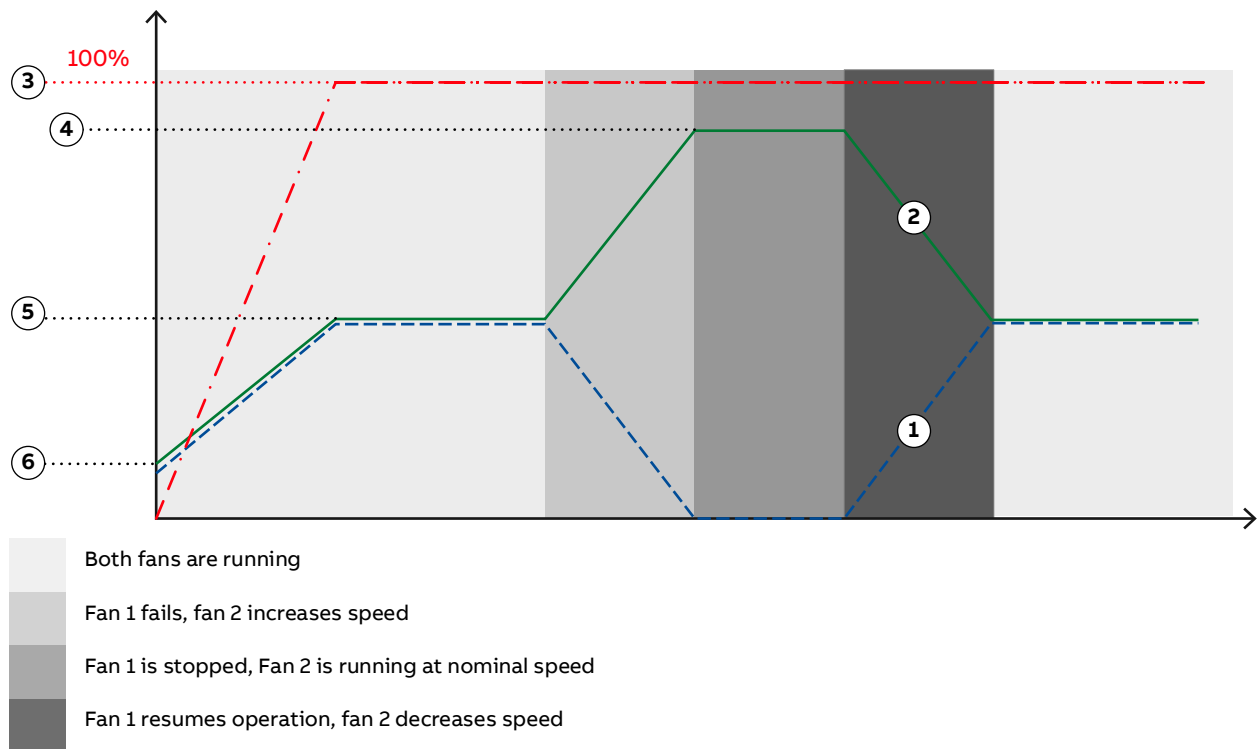

#### Key

- (1) Fan 1
- (2) Fan 2
- (3) Drive load
- (4) Nominal fan speed
- (5) Reduced fan speed
- (6) Minimum fan speed

**Figure 19 – Operating principles of redundant EC fans**

### 3.5.6. Air flow overview (AC and EC fans)

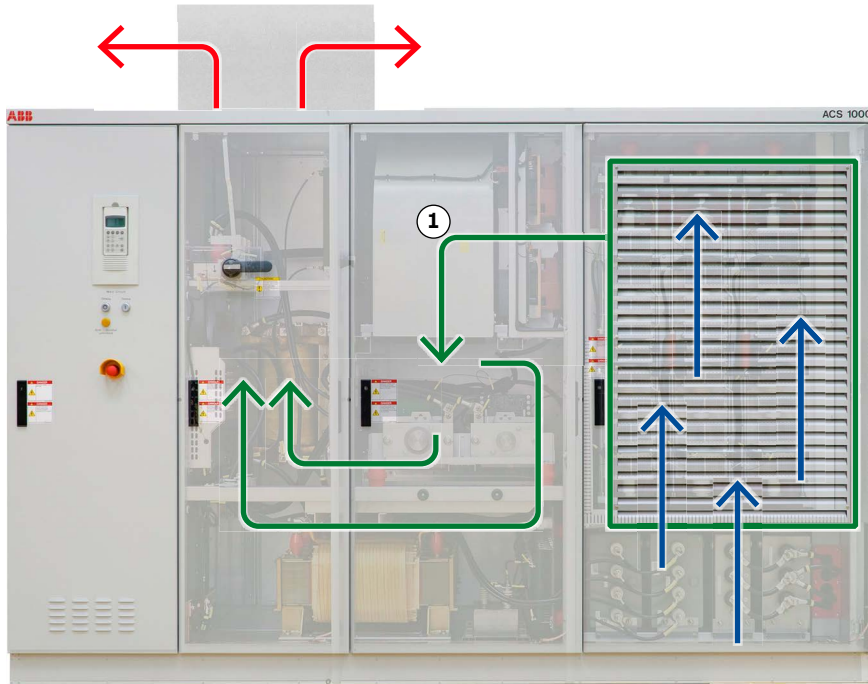
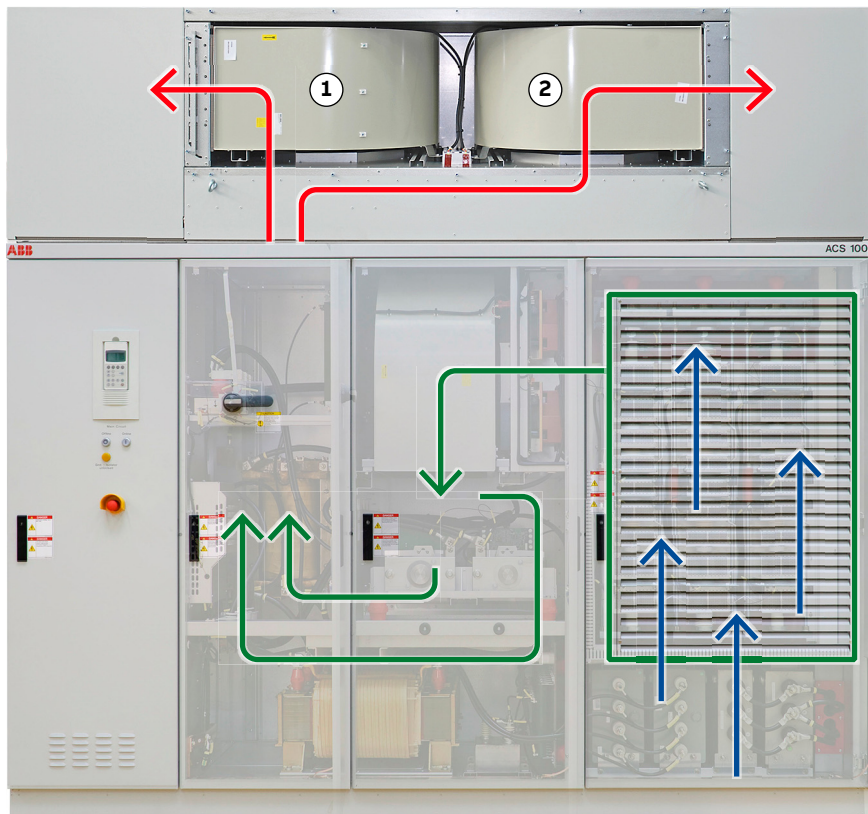

Figure 20 – Air flow: (1) non-redundant fan configuration



**Key**

- (1) Fan 1
- (2) Fan 2

Figure 21 – Air flow: redundant fan configuration

PRODUCT	DOCUMENT KIND	DOCUMENT ID.	REV.	LANG.	PAGE
ACS1000A	User manual	3BHS213401 E01	N	en	43/160

## 3.5.7. Monitoring the air pressure

### 3.5.7.1. Air pressure in the drive (AC fans only)

This type of supervision is only required for AC fans, which are used for UL or cUL certified drives. For EC fans, the supervision is integrated in the EC fan electronic board.

A pressure switch (1, Figure 22) in the control compartment monitors the air pressure in the drive.

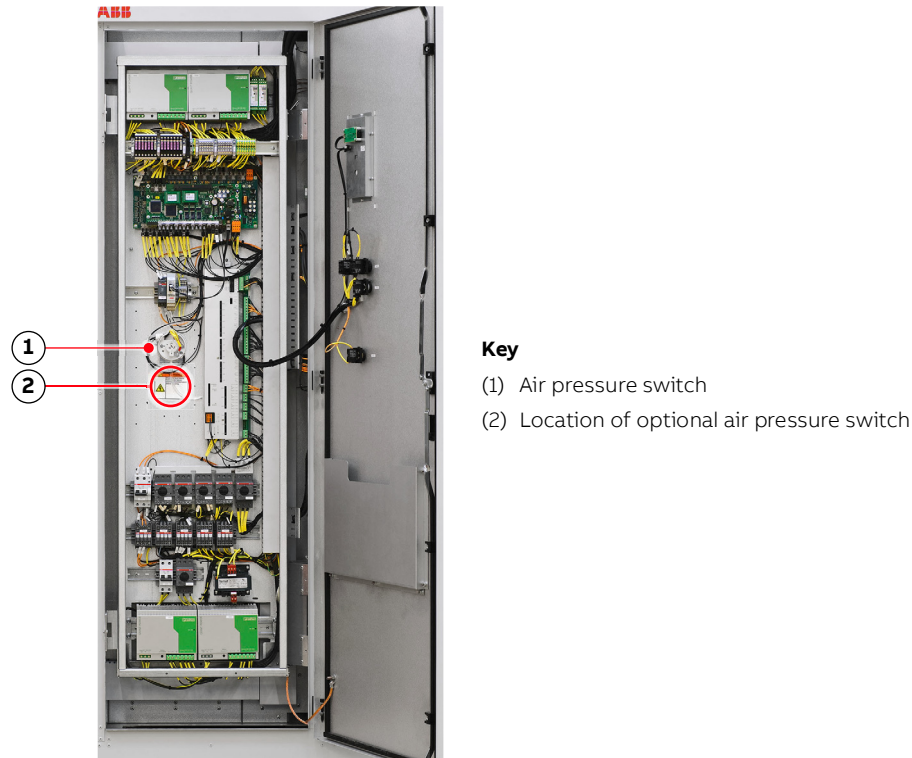

**Figure 22 – Air pressure switches**

When the pressure decreases and the response threshold of the pressure switch is reached, the following takes place:

- **Drives with non-redundant fan configuration:** The alarm FanDiffPres displays on the local control panel and the drive shuts down.
- **Drives with redundant fan configuration:** The alarm FanDiffPres displays on the local control panel and the drive switches on the stand-by fan. When the stand-by fan also fails, the drive shuts down.

### 3.5.7.2. Air pressure across filter mat (AC and EC fan types)

A separate optional air pressure switch (2 in Figure 22) monitors the pressure drop across the filter mat in the air intake. When the filter mat is clogged and the pressure drop reaches the specified final pressure loss, the alarm AirFiltSupv displays on the local control panel. The reaction of the drive on the alarm is programmable.

## 3.5.8. Adjustable parameters

For information on the parameters for the cooling system and their settings, see “Appendix G - Signal and parameter table”.

PRODUCT	DOCUMENT KIND	DOCUMENT ID.	REV.	LANG.	PAGE
ACS1000A	User manual	3BHS213401 E01	N	en	44/160

### 3.6. Cabinet design

The riveted and folded cabinet construction of the drive ensures a strong, flexible and self-supporting framework. The construction avoids the need for additional skeletal support and provides effective protection against electromagnetic emissions.

EMC has been achieved by applying a cabinet design consisting of folded, galvanized sheet metal plates (approximately 2 mm thick) and minimizing the space between the rivets. The inside walls of the cabinet are not painted, because paint tends to reduce the effectiveness of metallic bonding which is important for successful EMC.

Accordingly, only the front of the cabinet is painted while all other walls are galvanized. However, the cabinet can be ordered optionally with the whole of the outside painted. EMC performance is further enhanced by the use of metal cable ducts.

### 3.7. Door locking system

To ensure safety and to prevent the doors being opened unintentionally, all doors are lockable. The doors of compartments where medium voltages are present during operation (2, Figure 23) are electro-mechanically secured.

Additionally, the doors of the medium voltage compartments have locks with different inserts than the control compartment door. The different lock inserts ensure that these doors can only be opened by personnel authorized to do so.

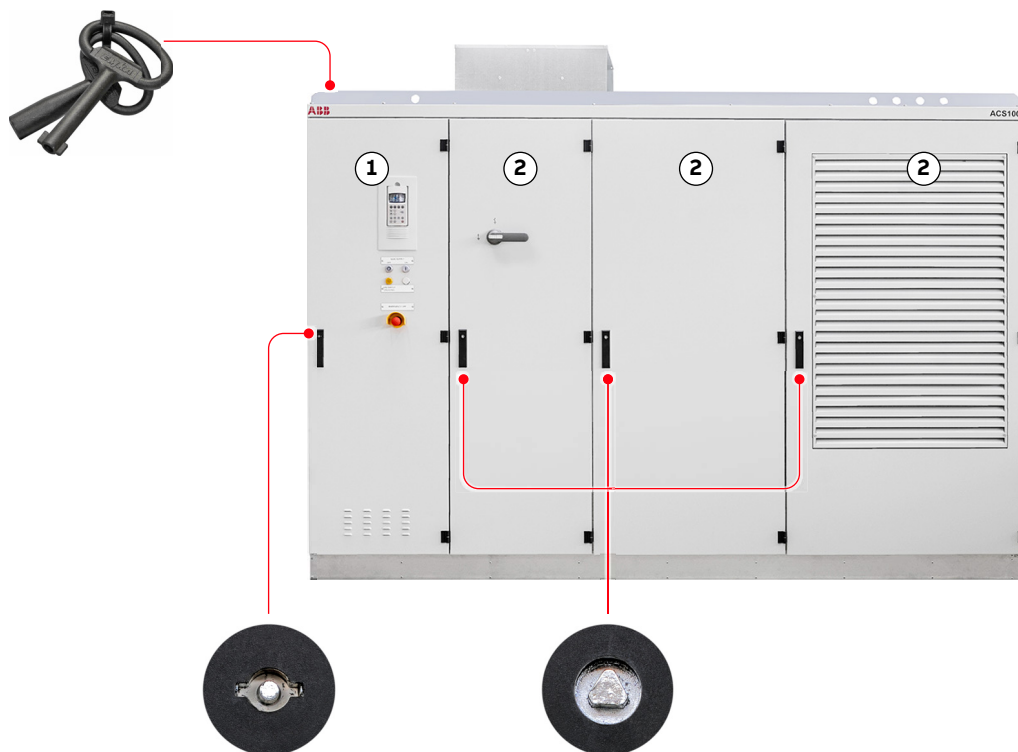

#### Key

(1) Door of control compartment

(2) Doors of rectifier and inverter compartment

#### Explanation

Partition of terminal compartment behind control compartment: bolted

Electro-mechanically locked doors cannot be opened when the drive is energized.

**Figure 23 – Door locks**

### 3.7.1. Optional cabinets

If medium voltages are present in an optional cabinet during operation (eg, braking chopper and output disconnecter), the door is secured by an electro-mechanical lock as well as a door monitoring switch. If the cabinet is UL certified, the door is further secured with extra screws. The lock and the switch release the door after the DC link of the drive has discharged and the drive has been grounded.

## 3.8. Arc resistant design (optional)

The optional “Arc Resistant Design” provides the drive with arc fault protection in accordance with IEC 62477-2.

The ABB arc resistant classes in Table 3 indicate the type of arc proofing that a drive uses. Depending on the drive configuration, classes I and II are available for an ACS1000A.

For information on the arc resistant design class of your drive, see the project-specific “Converter Data Sheet” (“Appendix B - Technical data” of the ACS1000A user manual).

**Table 3 – ABB arc resistant classes**

ABB class	Description
Class I	Protection based on arc prevention (NOT certified according to IEC 62477-2)
Class II	Protection based on arc resistant cabinet structure, IAC certified by 3rd body according to IEC 62477-2
Class III	Protection based on external arc fault limitation and elimination. HV fuses are applied externally to limit the arc fault current, IAC certified by 3rd body according to IEC 62477-2
Class IV	Fast arc detection and elimination, IAC certified by 3rd body according to IEC 62477-2

### 3.8.1. Internal arc classification (IAC)

The arc fault rating, which is based on arc fault tests, is on the label underneath the drive rating plate of the drive.

Internal Arc Classification (IAC)									
ABB Class II									
IAC	F	L	R	T	B	$I_A$	$t_A$	APR	SC
IEC 62477-2	2b	2b	2b	1	1	5 kA	0.5 s	Yes	No
Distance [m]	0.3	0.3	0.3	-	-				

3BHB049908R1205

**Figure 24 – IAC label example**

### 3.8.2. Associated protection requirement

The arc resistant design requires associated protections that are not included in the scope of the delivery, ie, a main circuit breaker.

For more information on the MCB:

- MCB overview: [2.4 Main circuit breaker protection device on page 24](#)
- MCB requirements: “Input circuit breaker engineering guideline” , 3BHS260163 E01

PRODUCT	DOCUMENT KIND	DOCUMENT ID.	REV.	LANG.	PAGE
ACS1000A	User manual	3BHS213401 E01	N	en	46/160

### 3.9. Space heaters

The optional space heaters protect the cabinet from condensation.

The drive switches on the space heaters when the cooling system is switched off.

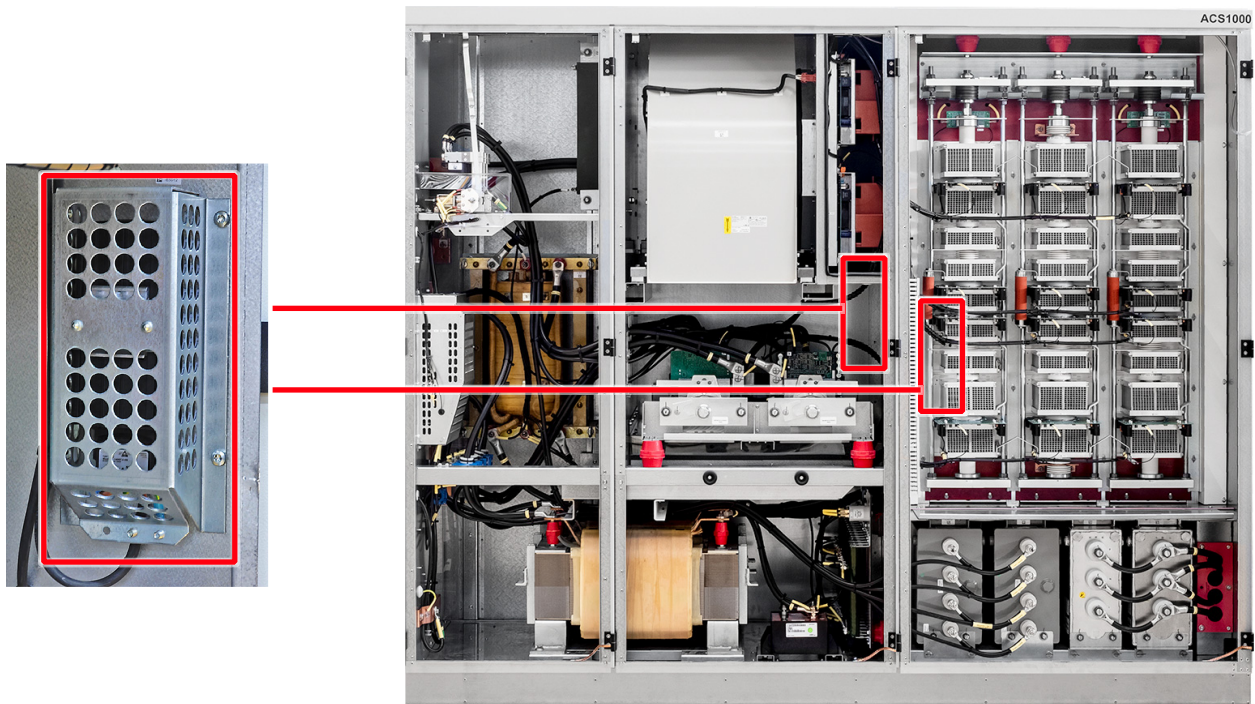
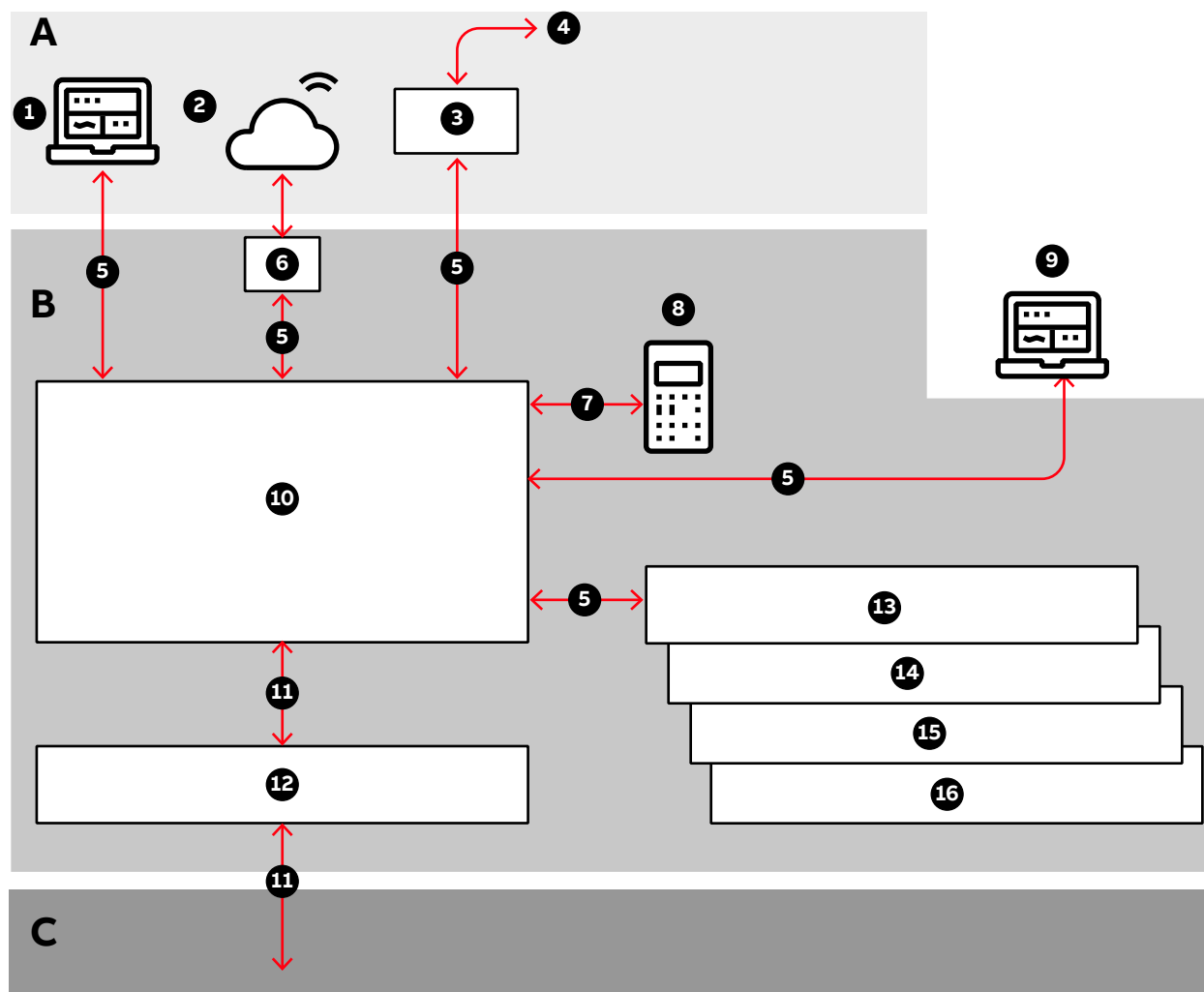

Figure 25 – Space heaters

## 4. Control system

### 4.1. Overview

The control compartment incorporates the hardware for the control, monitoring and protection functions of the drive, and the communication interfaces to the local control panel and to the remote control devices. Depending on the control concept of the drive system, the remote control devices include a higher-level control system and / or remote operator stations.



#### Key

- |                                 |                        |
|---------------------------------|------------------------|
| (1) ABB Ability                 | (9) PC tools           |
| (2) Cloud connectivity          | (10) AMC circuit board |
| (3) Fieldbus                    | (11) Fiber-optics      |
| (4) Higher-level control system | (12) INT circuit board |
| (5) DDCCS                       | (13) IOEC1             |
| (6) NETA-21                     | (14) IOEC2             |
| (7) RS485                       | (15) IOEC3 (optional)  |
| (8) CDP control panel           | (16) IOEC4 (optional)  |

**Figure 26 – Block diagram of control system with (A) customer interface, (B) control system, and (C) power electronics**

## 4.2. Main components

This section provides an overview of the main hardware components of the control system and their interconnection.

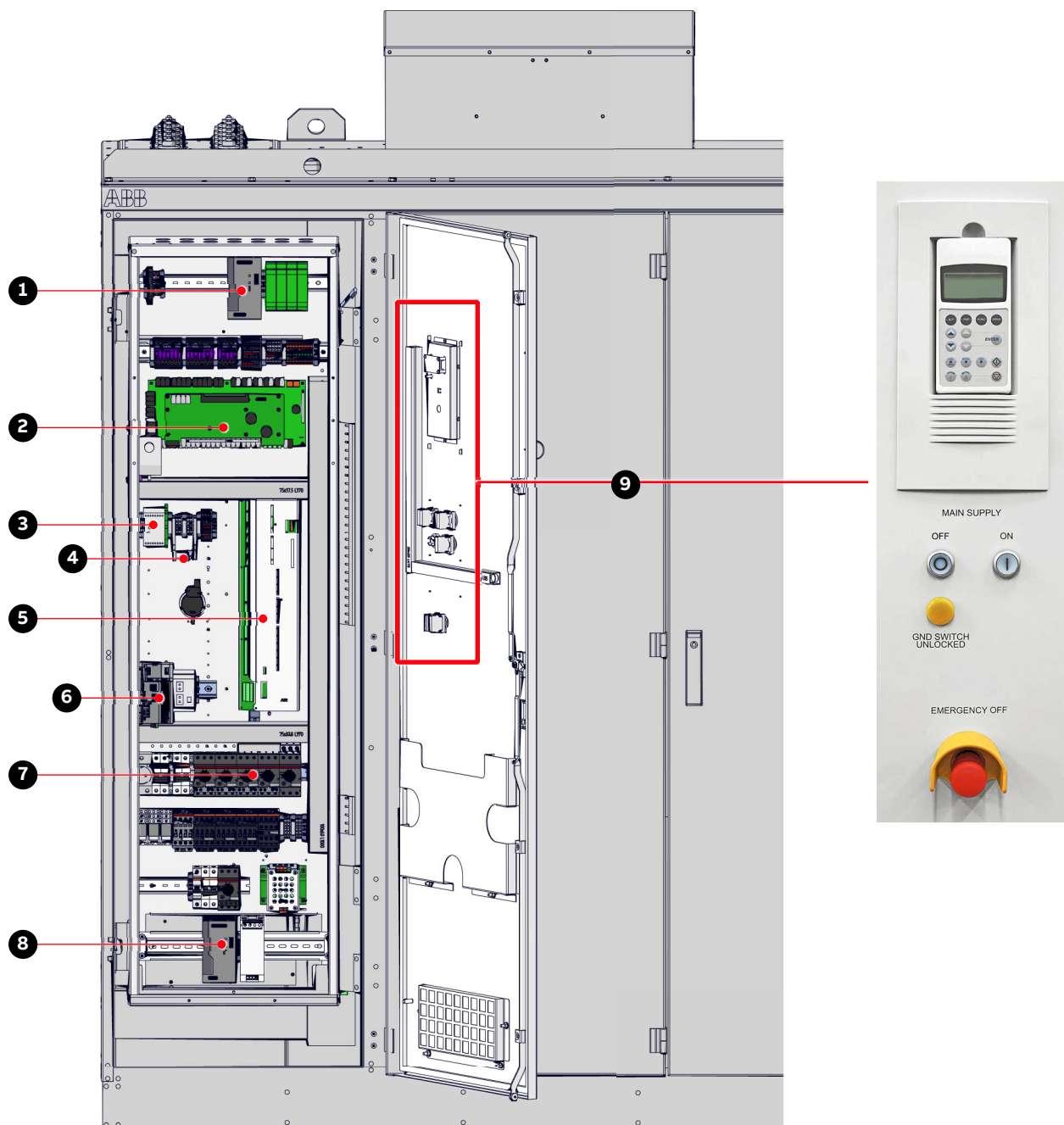

### Key

- |   |   |
|---|---|
| (1) Control power supply                    | (6) NETA-21                             |
| (2) AMC circuit board and INT circuit board | (7) Motor starters and circuit breakers |
| (3) Pulse encoder (option)                  | (8) Control power supply                |
| (4) Fieldbus interface (option)             | (9) Local control panel                 |
| (5) IOEC1 module                            |   |

**Figure 27 – Control compartment**

PRODUCT	DOCUMENT KIND	DOCUMENT ID.	REV.	LANG.	PAGE
ACS1000A	User manual	3BHS213401 E01	N	en	49/160

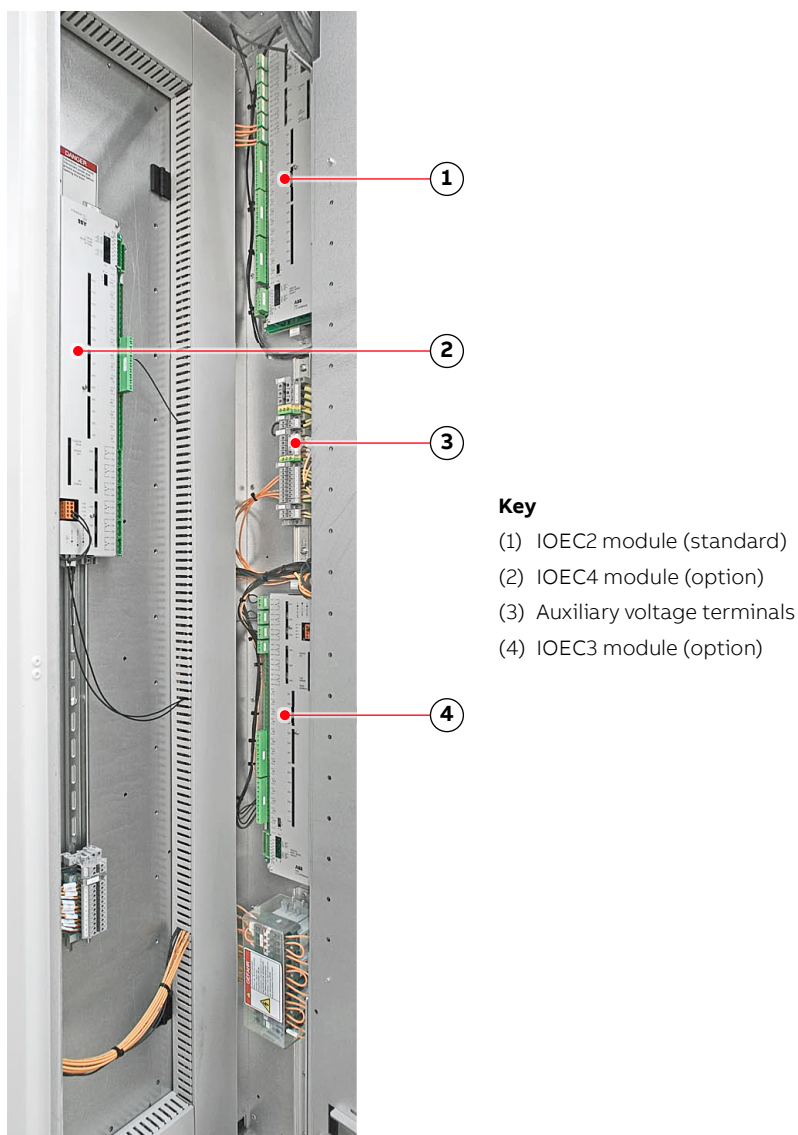

**Figure 28 – Control compartment – I/O devices**

For more information on the devices present in the control compartment, see “Appendix D - Wiring diagrams”.

### 4.2.1. Local control panel

The local control panel on the door of the control compartment serves as the basic user interface for monitoring, control, operation of the drive, and setting of parameters.

For more information, see [9 Operation on page 101](#) and [10 CDP control panel on page 112](#).

## 4.2.2. AMC circuit board

The AMC circuit board is the major component of the drive's control system and performs general drive control, motor control, and closed loop functions. The main internal control devices and the peripheral input and output interfaces to the customer communicate with the AMC circuit board via optical fibers.

The circuit board is fitted with a Motorola DSP processor and features two PPCS and eight DDCS communication channels. These communication channels are used for high-speed data transfer via the INT circuit board to the inverter.

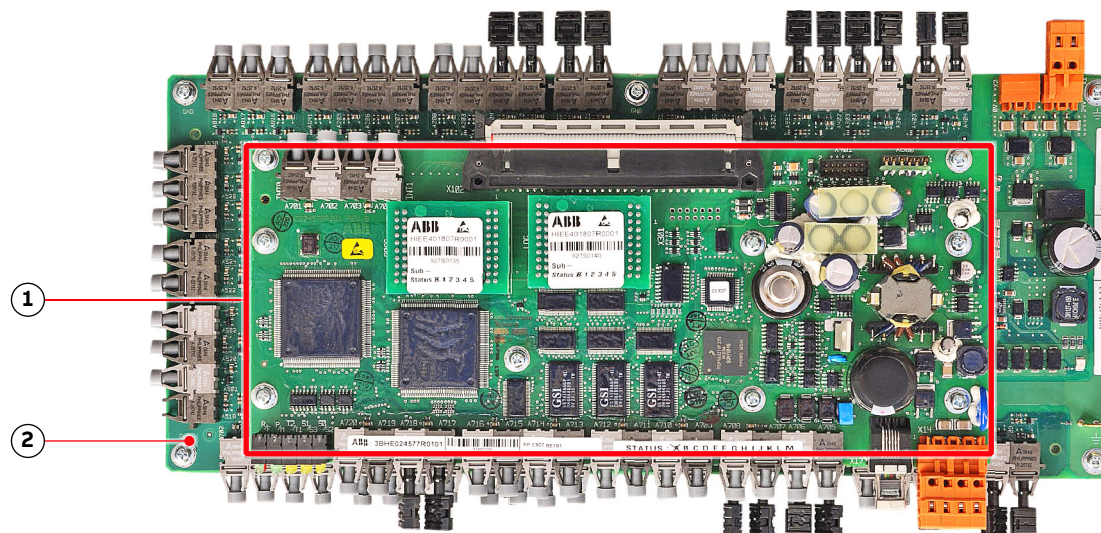

### Key

- (1) AMC circuit board
- (2) Interface circuit board (INT)

**Figure 29 – AMC circuit board**

### 4.2.2.1. Control tasks

The AMC circuit board has specific control and closed-loop tasks assigned to it. It processes drive and status information, performs the speed and torque control tasks, and monitors the operation of the drive.

All relevant drive variables (eg, speed, torque, current, voltage) are continuously monitored by the control system. Pre-programmed protection functions ensure that these variables remain within certain limits in order to maintain safe operation of the drive. These internal functions are not programmable by the user.

Optionally, the AMC circuit board can monitor signals from external equipment. These can be activated and adjusted with parameters.

Other general control, protection and monitoring tasks regarding the whole drive include control and monitoring of:

- [2.4 Main circuit breaker protection device on page 24](#)
- [3.4.4 Grounding switch on page 34](#)
- [3.5 Cooling system on page 40](#)

PRODUCT	DOCUMENT KIND	DOCUMENT ID.	REV.	LANG.	PAGE
ACS1000A	User manual	3BHS213401 E01	N	en	51/160

### 4.2.2.2. Parameters

The control system is configured, customized, and tuned with a set of application parameters. The application parameters are organized in functional groups and have factory-set default values. The default parameter values are adjusted during commissioning to the specific application of the drive in order to activate the specific control, monitoring and protection functions for the driven process, and to define the signals and data transferred between drive and external equipment.

For more information on the parameters for signal allocation, signal type selection, signal inversion, scaling, and filtering, see “Appendix G - Signal and parameter table”.

### 4.2.2.3. Main circuit breaker

The main circuit breaker (MCB) is an important switching and protection device of the drive system. Therefore it must only be controlled and monitored by the drive.

For more information, see the Main circuit breaker engineering guideline and [2.4 Main circuit breaker protection device on page 24](#).

### 4.2.2.4. Direct torque control

The speed and torque of the motor is controlled by DTC (Direct Torque Control). DTC provides accurate speed and torque control, and high dynamic speed response.

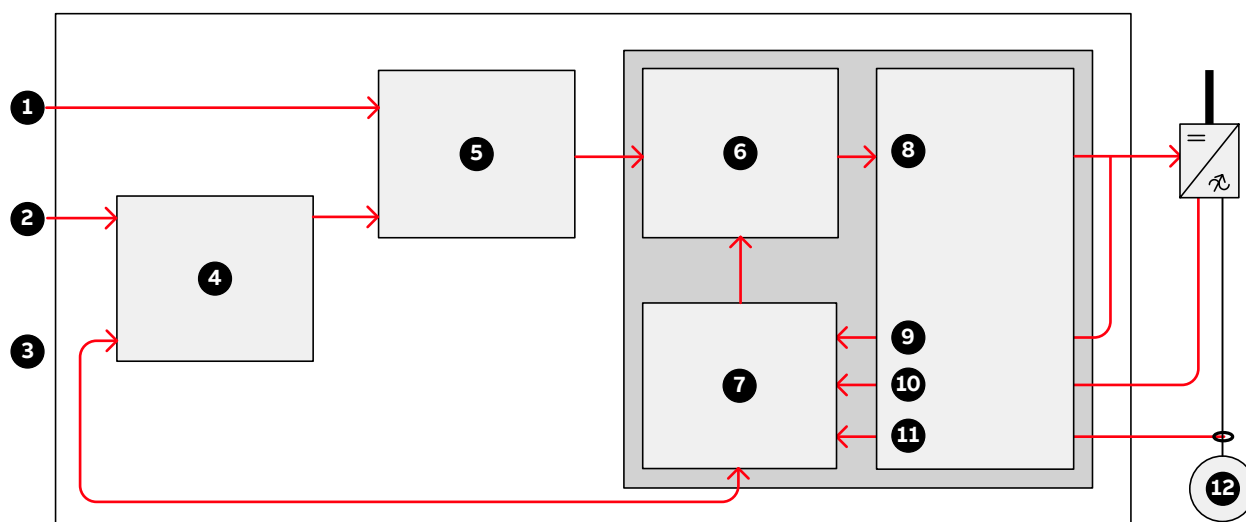

#### Key

(1) Torque reference	(7) Motor model
(2) Speed reference	(8) Switching logic
(3) Actual reference	(9) Switch positions
(4) Speed controller	(10) Voltage
(5) Torque reference controller	(11) Current
(6) Torque-flux comparator	(12) Motor

**Figure 30 – Direct torque control**

Switching of the semiconductors in the inverter is directly controlled in accordance with the motor core variables flux and torque.

The measured motor currents and DC link voltages are inputs to an adaptive motor model. The model produces exact values of torque and flux every 25 microseconds. Motor torque and flux comparators compare the actual values to reference values which are produced by the torque and flux reference controllers.

Depending on the outputs from the hysteresis controllers, the switching logic directly determines the optimum switch positions every 50 microseconds and initiates switching whenever required.

#### 4.2.2.5. Peripheral I/O devices

The peripheral input and output devices connected to the AMC circuit board include:

- Local CDP control panel
- IOEC I/O modules for parallel signal transfer to external devices (see [4.3.1 IOEC I/O modules on page 54](#))
- Serial communication interface (fieldbus) for serial data transfer to a higher-level control system (see [4.3.2 Serial communication interface \(fieldbus\) on page 58](#))
- Pulse encoder interface NTAC (option) (see [4.3.3 Pulse encoder interface NTAC \(option\) on page 59](#))
- PC-based service tools comprising:
  - DriveWare® software tools, commissioning and maintenance tools, ie, DriveWindow and DriveDebug, and DriveOPC for data transfer between ABB drives and Windows®-based applications.
  - NETA-21 for monitoring and diagnostics tool that allows access to the drive from any location in the world via a secure Internet connection.

#### 4.2.2.6. Control modes

The drive provides the following control modes:

- **Speed control mode:** Default control mode of the drive. The control mode can be used for applications where constant speed is required, such as pumps, fans and conveyors.
- **Torque control mode:** used for processes that require torque control (eg, mixers and slave drives). The torque reference comes from a process control system or a control panel.
- **PID control mode:** controls the process variable (eg, pressure, level or flow) by adjusting the speed of the motor accordingly.

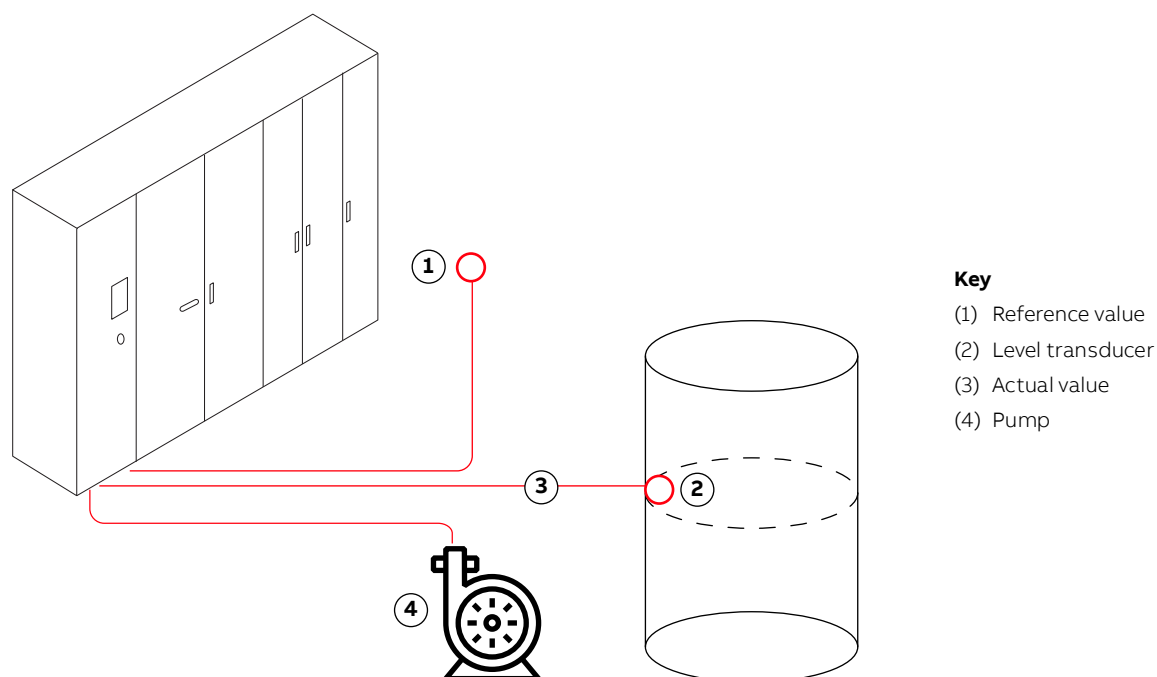

#### Key

- (1) Reference value
- (2) Level transducer
- (3) Actual value
- (4) Pump

Figure 31 – PID control mode

PRODUCT ACS1000A	DOCUMENT KIND User manual	DOCUMENT ID. 3BHS213401 E01	REV. N	LANG. en	PAGE 53/160
---------------------	------------------------------	--------------------------------	-----------	-------------	----------------

## Application examples

- Booster pumps of municipal water supply systems
- Automatic level control of water reservoirs
- Booster pumps of district heating systems
- Speed control of different types of material handling systems where the material flow has to be regulated.
- Sequential control mode: used in processes that require different constant speed settings and/or different acceleration and/or deceleration settings in addition to an adjustable speed reference value.

Up to seven constant speed settings and two acceleration and/or deceleration settings are possible. The selection of the different settings can be automated by a process control system or can be made manually by selector switches that are connected to the corresponding digital inputs of the drive.

The preset values of a control mode can be left unchanged or they can be set individually by the commissioning engineer as required for the application.

For more information on control mode settings, see “Appendix G - Signal and parameter table”.

### 4.2.2.7. Operating modes

The drive provides the following operating modes:

- **Master-follower operating mode:** used for applications with several drives where the motor shafts are coupled to each other (eg, gearing, chain, belt). Owing to the master-follower operating mode the load can be evenly distributed between the drives or at some adjustable other ratio which depends on the process.
- **Hand-auto operating mode:** suitable for applications where the speed has to be controlled automatically by a process automation system and manually by an external control panel. The active control station is selected via a digital input.  
The operating mode is also recommended when two external control stations exist from where the reference value can be set and the drive can be started and stopped. The external control station is selected via a digital input.

## 4.3. I/O interfaces

### 4.3.1. IOEC I/O modules

Internal and external, analog and binary I/O signals are connected to the control system by IOEC modules.

The standard I/O includes one external module (IOEC 2, IOEC 3) and one module that is internal to the drive operation (IOEC 1). The standard I/O provides standard control and supervision functionalities sufficient for most applications.

The drive can include an optional expansion I/O that includes an external module (IOEC 4). These expansion modules provide extra inputs and outputs for control and supervision as may be required by the drive or the customer to support various control options.

PRODUCT	DOCUMENT KIND	DOCUMENT ID.	REV.	LANG.	PAGE
ACS1000A	User manual	3BHS213401 E01	N	en	54/160

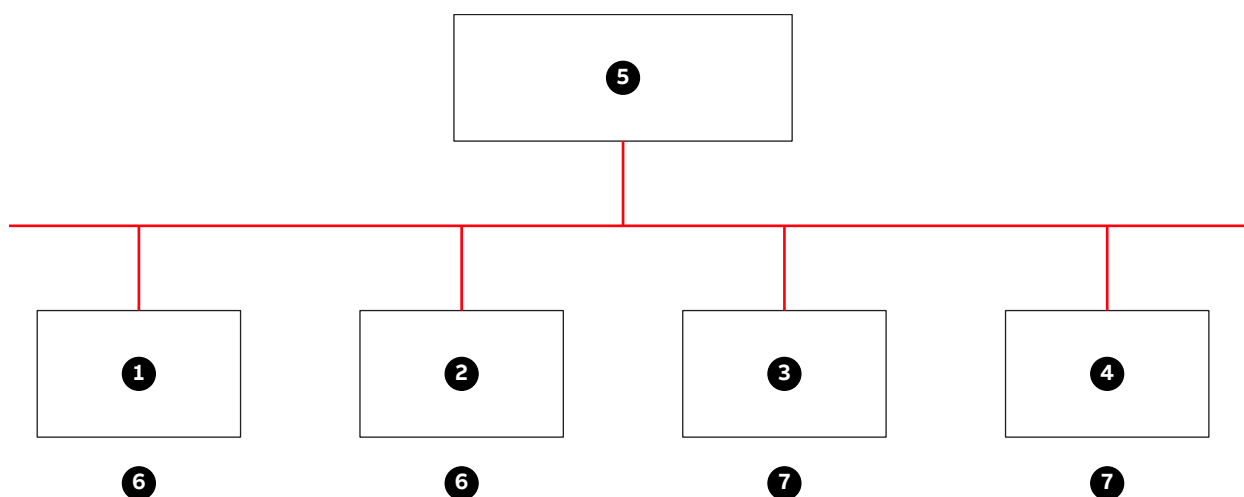
**Key**

- (1) IOEC 1
- (2) IOEC 2
- (3) IOEC 3
- (4) IOEC 4

- (5) AMC circuit board
- (6) Standard
- (7) Option

**Figure 32 – IOEC interfaces overview****4.3.1.1. IOEC module configuration**

Each IOEC module is configured with both analog and digital inputs and outputs as shown in the following tables.

**Table 4 – IOEC module configuration - analog inputs**

No. of I/O	4
Resolution	10 bit
Signal interface	Floating, galvanically isolated
Signal level	0 - 20 mA, 4 - 20 mA, 0 - 10 V, 2 - 10 V Individually scalable by parameter
Input resistance	$R_{in} = 105 \Omega$ for current input $R_{in} = 250 \text{ k} \Omega$ for voltage input
Common mode voltage	Maximum: 48 V
Isolation level	350 V (AC)

**Table 5 – IOEC module configuration - analog outputs**

No. of I/O	2
Signal range	0 - 20 mA (load impedance: max. 250 $\Omega$ )
Resolution	12 bit
Isolation level	350 V (AC)

**Table 6 – IOEC module configuration - digital inputs**

No. of I/O	14
Signal level	22 - 120 V (DC) * *for the 80 to 120V range, an IOEC adapter board is required 22 - 250 V (AC)
Logical threshold	< 13 V (AC or DC) $\triangleq$ "0", > 16 V (AC or DC) $\triangleq$ "1"
Input current	13 mA steady state (14 mA max. inrush) at 24 V (DC) 11.5 mA steady state (80 mA max. inrush) at 120 V (DC) 10.5 mA steady state (92 mA max. inrush) at 230 V (AC)
Isolation level	1350 V (AC)

**Table 7 – IOEC module configuration - digital inputs**

No. of I/O	6		
Signal level	Maximum: 120 V (DC) or 250 V (AC)		
Isolation level	4000 V (AC)		
Switching capacity	Voltage	Switching current	Steady state current
	24 V (DC)	8 A	6 A
	24 V (AC)	8 A	6 A
	48 V (DC)	1 A	6 A
	48 V (AC)	8 A	6 A
	120 V (DC)	0.4 A	6 A
	120 V (AC)	8 A	6 A
	230 V (AC)	8 A	6 A

#### 4.3.1.2. Internal voltage supply (24 V)

One isolated DC/DC converter supplies an overload protected voltage of 24 V (DC) to operate digital inputs from passive contacts. The output is protected by a PTC-resistor against short-circuit and external applied overvoltages.

**Table 8 – 24 V internal voltage supply**

Output voltage	Available output voltage
Unregulated 24V	180 mA

### 4.3.1.3. Module terminals

The IOEC module has terminal blocks for internal wiring and indicator LEDs for diagnostic and I/O status.

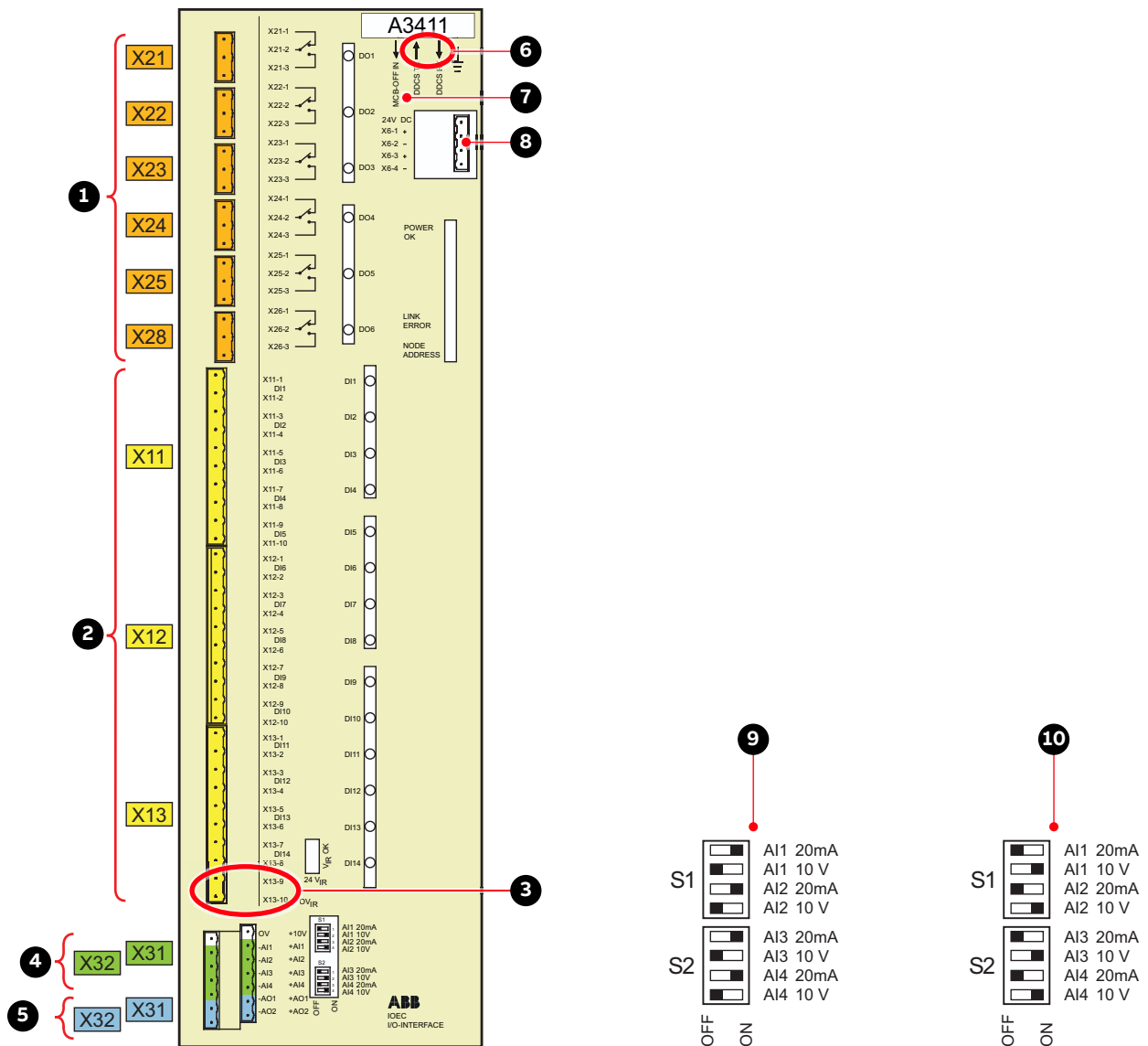

**Key**

- (1) Digital outputs
- (2) Digital inputs
- (3) 24 V internal voltage
- (4) Analog inputs
- (5) Analog outputs
- (6) DDCS fiber optics
- (7) I/O Emergency OFF function
- (8) Power supply (factory-installed wiring)
- (9) Voltage mode
- (10) Current mode

**Figure 33 – IOEC module**

### 4.3.1.4. I/O device identification

The I/O modules are identified on the part with an identification label (1, Figure 34), in the wiring diagram, and in the software by the wiring diagram identification number (2, Figure 34).

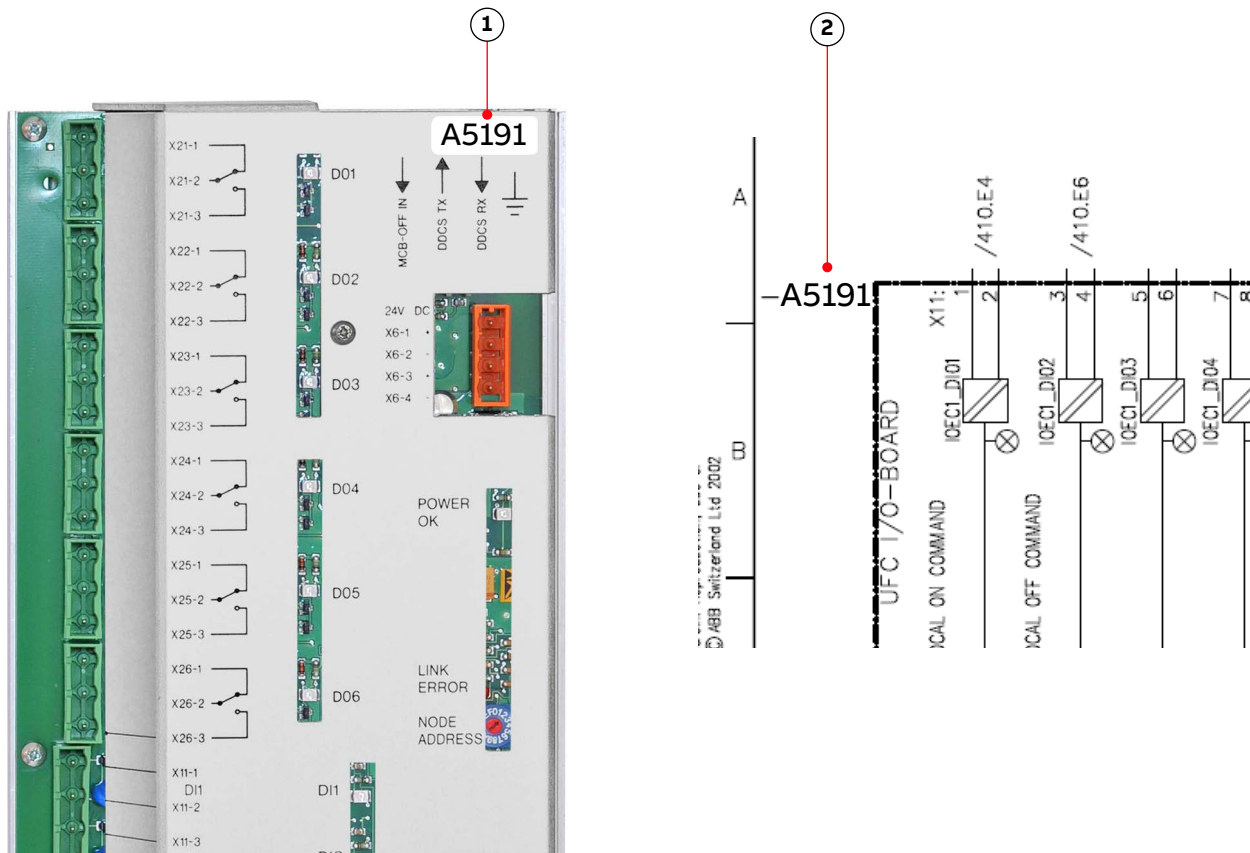

**Key**

- (1) Identification label
- (2) Identification number

**Figure 34 – IOEC module identification**

The way the identification number is built directly corresponds to the wiring diagram as can be seen in Figure 34. The letter A represents the kind of part we have, an assembly, the next three digits are the page number the part is located on, page 191, and the last digit, 1, means that our part is the first assembly on the page. This identification label number is the key to track electrical devices throughout the drive and in the ABB documentation.

The designation for each IOEC module is shown in Table 9 .

**Table 9 – IOEC module identification**

I/O module type	Wiring diagram designation for module identification
IOEC1	A5191
IOEC2	A5201
IOEC3	A5211
IOEC4	A5221

### 4.3.2. Serial communication interface (fieldbus)

To identify the serial communication interface in the drive, see “Appendix D - Wiring diagrams”. For more information on the device, consult the relevant manual:

- Modbus TCP - “Ethernet - NETA-21 remote monitoring tool user manual”, 3AUA0000096939
- Modbus RTU - “Modbus - NMBA-01 installation and start-up guide”, 3AFY58919772
- Profibus - “Profibus - NPBA-12 installation and start-up guide”, 3BFE64341588
- DeviceNet - “DeviceNet - NDNA-02 installation and start-up guide”, 3AFY58919829

### 4.3.3. Pulse encoder interface NTAC (option)

The NTAC interface is part of the control system of the drive if pulse encoder feedback is used to control the motor.

For more information on the device, see “Installation and start-up guide for the pulse encoder module NTAC-0x” , 3AFY58919730.

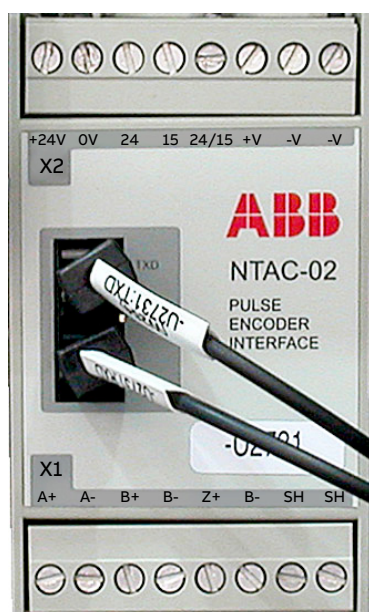

Terminals X1			Terminals X2		
1	A+	Channel A	1	-V	0 V
2	A-		2	-V	24 V
3	B+	Channel B	3	+V	
4	B-		4	24/25	
5	Z+	Channel Z	5	15	
6	Z-		6	24	
7	SH	Shield	7	0 V	
8	SH		8	+24 V	

Figure 35 – NTAC-02 pulse encoder interface

## 5. Transportation, storage and disposal

### 5.1. Safety



The drive must only be handled by personnel who are skilled and experienced in unpacking and transporting heavy equipment.

### 5.2. Transport conditions

The transport conditions for the drive are based on IEC 60721-3-2.

- **Transport conditions:** 2K12 / 2B1 / 2C2 / 2S5 / 2M4
- **Maximum transport time:** 2 months

### 5.3. Unpacking and inspection

1. Remove all packaging material carefully.
2. Check the drive and accompanying equipment for damages.
3. Compare the complete delivery with the purchase order and the packing list.
4. If parts are missing or damaged, immediately inform the shipping company and the ABB service organization (include photographs of the damaged parts).

PRODUCT	DOCUMENT KIND	DOCUMENT ID.	REV.	LANG.	PAGE
ACS1000A	User manual	3BHS213401 E01	N	en	60/160

## 5.4. Lifting and transportation



### **WARNING**

**Risk of serious injury!** Incorrect securing and lifting of loads can cause serious injury and damage the equipment.

- Lift operations **MUST** be performed by qualified personnel in accordance with local lifting laws!
- Use a crane; **DO NOT** use a forklift
- If the drive is delivered in several transport units, **DO NOT** lift and move the drive by crane after the transport units have been joined
- Use suitable lifting gear for the load weight, eg, web slings, chain slings, round slings, and shackles
- Only use the original lifting attachments with the original mounting bolts and washers to transport the equipment
- For a drive with the optional redundant fan ([6.7 Installing the redundant fan unit on page 71](#)), **DO NOT** use the rotating eyebolts on the fan housing when you lift the drive
- Before use, always check the lifting attachments for damage, eg, corrosion and cracks; **DO NOT** attempt to lift equipment with a damaged lifting attachment; contact ABB for a replacement before you proceed
- Always transport the load in an upright position
- Always observe the center of gravity
- **DO NOT** lift more than one load at a time



Refer to “Appendix C - Mechanical drawings” for relevant dimensions and weights.

### **NOTICE**

**Risk of component damage!** Dirt and metallic dust can cause failure when the drive is energized.

- Keep the cabinet doors closed during lift operations

PRODUCT	DOCUMENT KIND	DOCUMENT ID.	REV.	LANG.	PAGE
ACS1000A	User manual	3BHS213401 E01	N	en	61/160

### 5.4.1. Lifting attachment types

**IMPORTANT!** The lifting attachments, which are included with the delivery, are intended exclusively for use with ACS1000A equipment. Any use beyond this is strictly prohibited. Only use the original lifting attachments to transport the equipment.

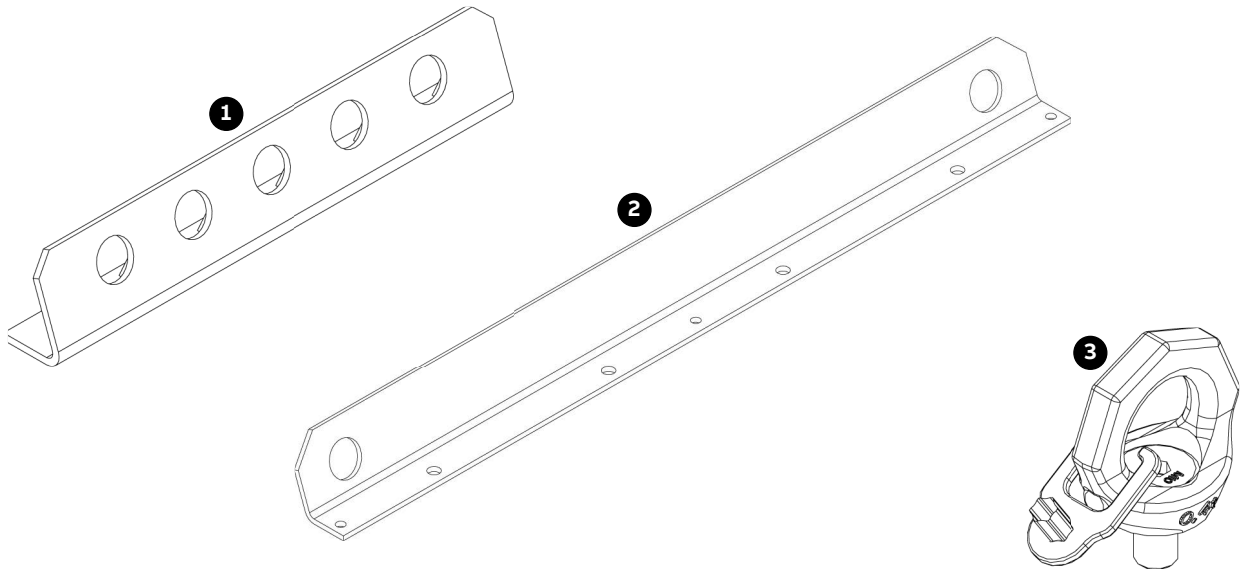

Key	Explanation
(1) Top lifting rail	For lifting a standard drive
(2) Top lifting rail	For lifting an additional cabinet
(3) M8 Rotating eyebolt	For lifting redundant fan unit

**Figure 36 – Lifting attachment types**

## 5.4.2. Lifting with the top lifting rails

The top lifting rails are on the roof of standard drives and additional cabinets.

1. Attach slings to the hole with the recommended lifting point labels (1) on each of the 4 top lifting rails, eg, with shackles (see Figure 39).

**NOTICE** If the labels are not visible, attach the slings to the middle holes of the rails.

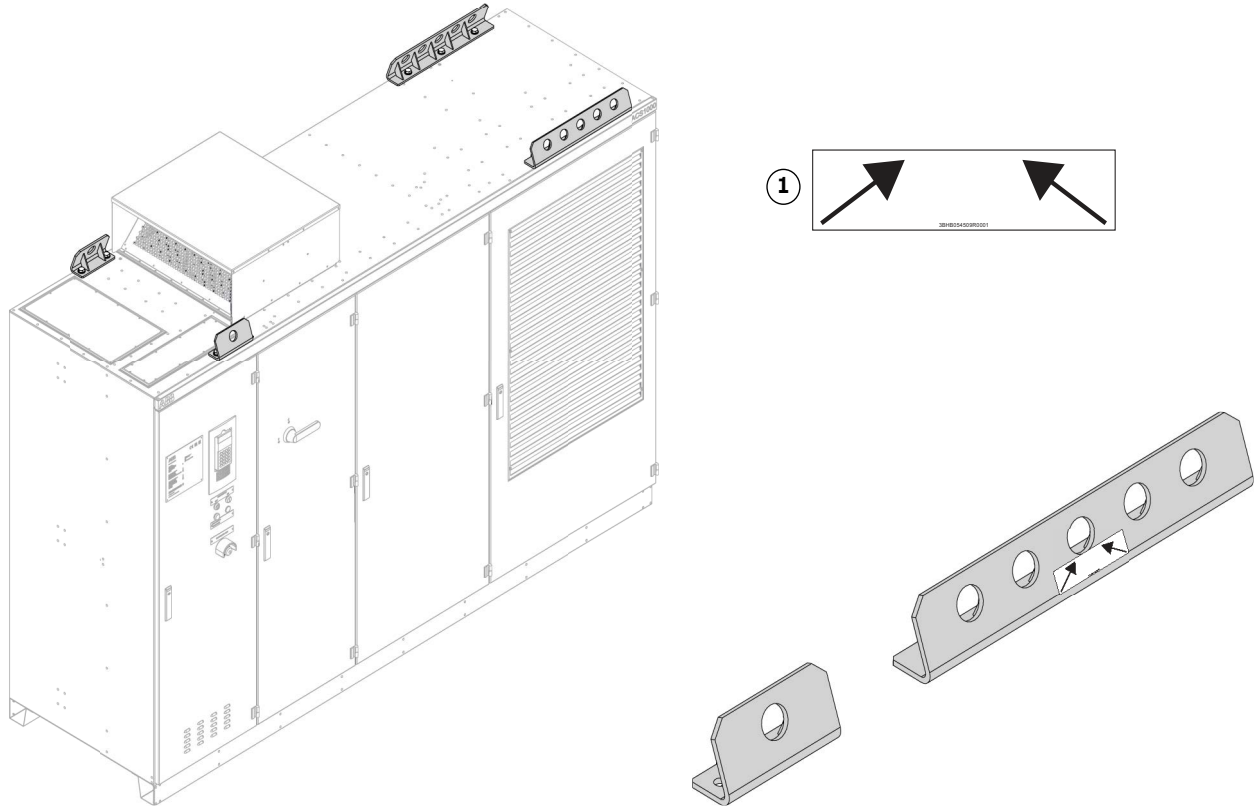

**Figure 37 – Top lifting rails with (1) recommended lifting points**

2. Ensure that the maximum vertical slope angle of the slings is 60° (2, Figure 39).
3. Lift the drive slowly and steadily to the required clearance height.
 

**CAUTION!** If the horizontal position of the load does not remain stable, lower the drive to the floor, attach the slings to different holes on the top rails, and then lift the load again while checking the horizontal position.

If you need to remove the top lifting rails (special case only – ABB recommends that the rails remain on the roof):

4. Unbolt and remove the top rails (3, Figure 38).
5. Grease and re-insert the bolts with the washers from Step 4 into the mounting holes for the top rails on the roof.
6. Tighten the bolts to the torque that is specified in Table 10.
 

⇒ The IP rating of the drive is restored.
7. Store the top rails in a dry, non-corrosive environment for when you need to move the drive again, eg, when the drive is at end of life (see [5.4.4 Reinstalling lifting attachments on page 65](#)).

PRODUCT	DOCUMENT KIND	DOCUMENT ID.	REV.	LANG.	PAGE
ACS1000A	User manual	3BHS213401 E01	N	en	63/160

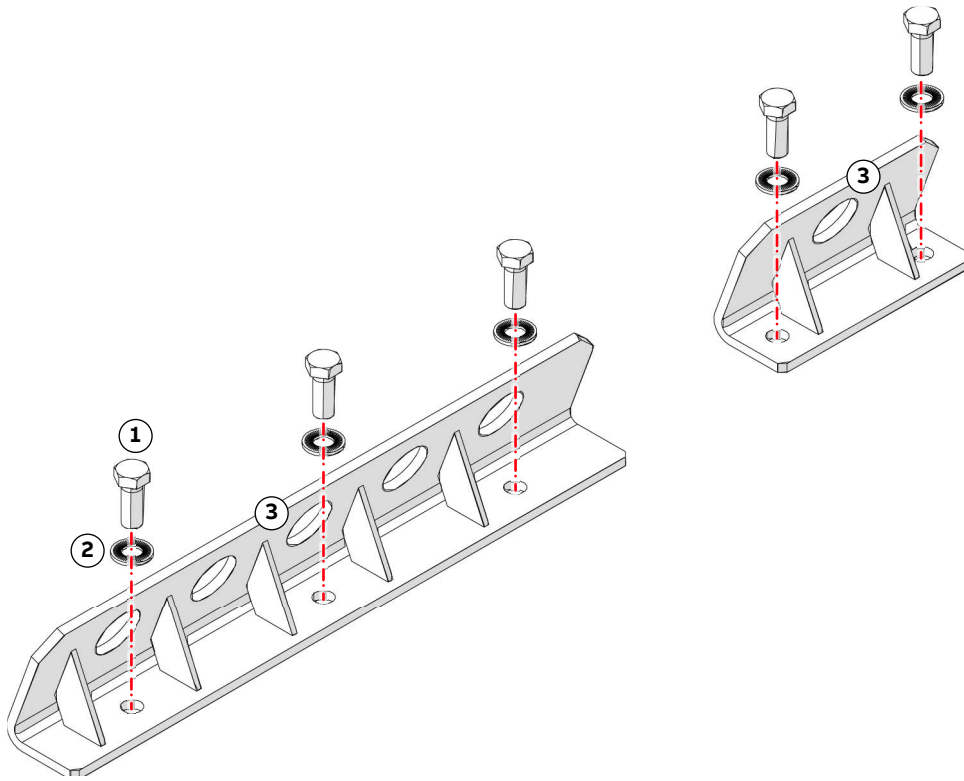

**Key**

- (1) Mounting bolt (min. A2-70)
- (2) Ripp-Lock washer
- (3) Top rail

**Figure 38 – Mounting bolts and washers for top rail**

### 5.4.3. Lifting with rotating eyebolts (redundant fan unit)

Rotating eyebolts, which are required to lift a redundant fan unit, are installed in the factory.

The following instructions describe how to use the eyebolts during a lifting operation. For instructions on how to lift and install a redundant fan unit, see [6.7 Installing the redundant fan unit on page 71](#)).

The lifting procedure requires a crane with a lift frame or a spreader frame.

1. Rotate the eyebolts (1) in the pull direction (3), ie, sling direction, and then attach slings to the eyebolts with safety hooks or shackles (2).  
**CAUTION!** DO NOT run slings through the eyebolts!

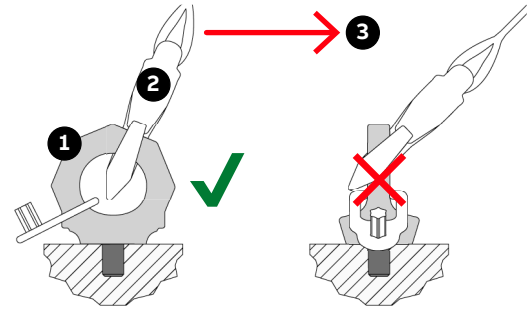

Referring to Fig. 39, page 66:

2. Protect the edges and other protrusions on the load from direct contact with the lifting gear, eg slings.
3. Lift the load slowly and steadily, with no abrupt stops, in an upright position to the required clearance height.  
**CAUTION!** Keep an eye on the horizontal position of the load and reposition the slings when necessary.

### 5.4.4. Reinstalling lifting attachments

If you need to reinstall factory-mounted lifting attachments, eg, when the drive is at end of life, tighten the mounting bolts to the torque that is specified in Table 10.

**Table 10 – Lifting attachment specifications**

Type	Mounting bolt and washer	Torque (Nm)	ABB ID
Top lifting rail for standard drive	4 × M16×40 (A2-70) Washer Ripp lock	204	NB 312350P0464 9ABA450078P0008
Top lifting rail for additional cabinet	3 × M8×25 combi screw 8.8	24	9ABA450093R0311
M8 rotating eyebolt	M8	10	3BHE015753P0008

### 5.4.5. Sling configuration for top lifting rails

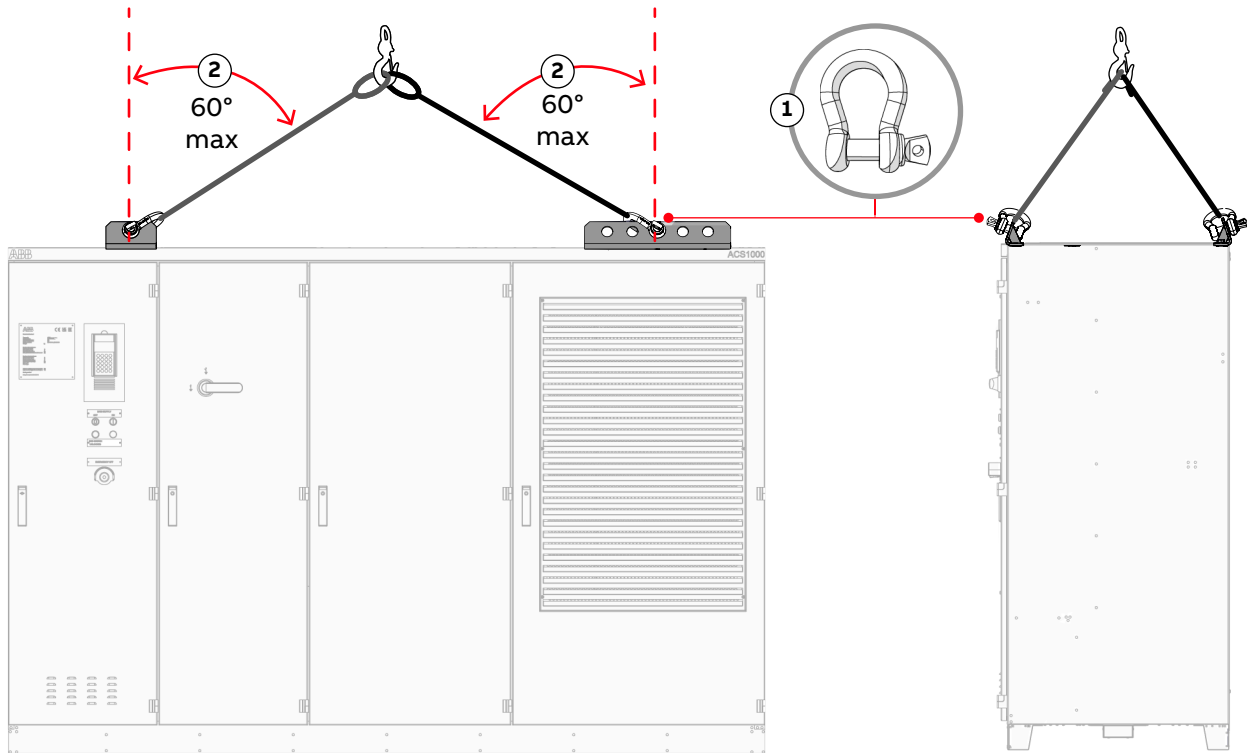

**Key**

- (1) Shackle
- (2) Sling slope angle (maximum 60°)
- (3) Top lifting rail

**Figure 39 – Sling configuration - standard case with top lifting rails**

PRODUCT ACS1000A	DOCUMENT KIND User manual	DOCUMENT ID. 3BHS213401 E01	REV. N	LANG. en	PAGE 66/160
---------------------	------------------------------	--------------------------------	-----------	-------------	----------------

## 5.5. Storage

### 5.5.1. Storage conditions

The minimum requirements for storage are based on IEC 60721-3-1.

- **Conditions:** 1K22 / 1B1 / 1C2 / 1S11 / 1M11

#### 5.5.1.1. Storage time

The drive can be stored for up to one year in the original packaging as long as it is not damaged or opened.

NOTE – For information on longer storage periods, contact the ABB service organization.

### 5.5.2. Storing the drive

If the drive is taken out of service for a longer time proceed as follows:

1. Remove the batteries (if applicable).
2. Cover all cable inlets and ventilation slots with an impermeable plastic or aluminum foil and a wooden panel.
3. Add a desiccant of the appropriate quality:
  - 1 unit desiccant (30 g) absorbs 6 g water vapor.
 The following quantity is required when using a polyethylene foil:
  - 10 units/m<sup>2</sup> foil
4. Close and lock the doors of the cabinet.
5. Use polyethylene or equivalent for packaging:
  - 0.3 g/m<sup>2</sup>/24h water vapor diffusion
6. Attach humidity indicators to the packaging.

The storage conditions and the packaging should be checked regularly. Any damages that occur during the storage period should be repaired immediately.

PRODUCT	DOCUMENT KIND	DOCUMENT ID.	REV.	LANG.	PAGE
ACS1000A	User manual	3BHS213401 E01	N	en	67/160

### 5.5.3. Storage and handling of spare parts



#### NOTICE

**Risk of component damage!** Electronic devices (eg, circuit boards, semiconductors) are sensitive to electrostatic discharge (ESD), which can damage these devices. Observe the following to maintain spare parts in good condition and to keep the warranty valid during the warranty period:

→ Apply ESD handling precautions before handling these devices.

#### 5.5.3.1. Warranty information

**IMPORTANT!** Check the spare parts immediately after receipt for damages and report any damage to the shipping company and the ABB service organization.

- Keep spare parts in their original packaging
- Store printed circuit boards in antistatic bags or boxes
- Storage temperature range: -5 °C to +55 °C
- Storage place requirements:
  - Free of vibration and shock
  - Protected against dust, sand, vermin and insects
  - Free of corrosive gases, salt or other impurities that could damage electronic equipment
  - Dry with NO condensation
  - Relative air humidity: 5 to 85%  
If in doubt whether the maximum allowed humidity is exceeded, protect the spare parts with an external heater.
- DO NOT touch a component without wearing a wrist grounding strap.
- Put the component on a grounded working surface protected against electrostatic discharges
- Hold the component only at the edge

## 5.6. Disposal of packaging materials and components

Dispose of the packaging materials and the components at the end of the lifetime of the drive according to local regulations.

PRODUCT	DOCUMENT KIND	DOCUMENT ID.	REV.	LANG.	PAGE
ACS1000A	User manual	3BHS213401 E01	N	en	68/160

## 6. Mechanical installation

### 6.1. Safety



All installation work must be carried out by qualified personnel according to the site and equipment requirements and in compliance with local regulations.

### 6.2. Overview of installation work

The installation includes the following work:

- “Preparing the floor”, page 70
- “Fixing the cabinet to the floor”, page 70
- “Assembling and installing the air exhaust hood”, page 71
- “Installing the redundant fan unit”, page 71

### 6.3. General notes on installation

#### **NOTICE**

**Risk of component damage!** Foreign matter and particularly metallic dust can cause failure and damage when the drive is energized.

- Ensure that foreign matter cannot enter the cabinet:
  - Close the doors and cover openings completely when work is discontinued.
  - Retrieve any foreign matter which accidentally dropped into the cabinet.

#### 6.3.1. Dimensions and clearances

See “Appendix C - Mechanical drawings” for information on:

- Cabinet dimensions
- Clearances to be observed
- Mounting hole sizes

#### 6.3.2. Cabinet roof

The cabinet roof is not designed as a mounting base for, eg, foreign devices, cable ducts. Therefore, it is not permitted to install any foreign device on the roof.

#### 6.3.3. Fire protection

To prevent fire spreading into the drive, apply suitable fire protection measures.

#### 6.3.4. Cable duct material

- Use non-flammable material with non-abrasive surface.
- To prevent dust, humidity and animals entering the cabinet, protect the cable entries.

PRODUCT	DOCUMENT KIND	DOCUMENT ID.	REV.	LANG.	PAGE
ACS1000A	User manual	3BHS213401 E01	N	en	69/160

## 6.4. Preparing the floor

Condition of the floor:

- Must support the weight of the cabinet
- Overall incline across 5 m must not exceed 5 mm
- Even
- Non-flammable, smooth and non- abrasive
- Protected against humidity diffusion

## 6.5. Fixing the cabinet to the floor

**IMPORTANT!** If the doors of medium voltage compartments cannot be opened, contact the ABB service organization

1. Drill fixing holes into the floor as indicated on the layout drawing.
2. When the cabinet is in place, check if the doors are misaligned.  
NOTE – If the doors DO NOT open and close properly, place leveling plates at the appropriate points (arrows in Figure 40).
3. Recommended size: 80 x 300 x 0.5 mm



**Figure 40 – Leveling the drive**

4. Fix the cabinet to the floor.  
NOTE – Floor fixings are not supplied. ABB recommends anchor bolts (Figure 41) or M16 screws and nuts.
5. Insert the screws from the ends of the cabinet base or via the holes inside the cabinet.

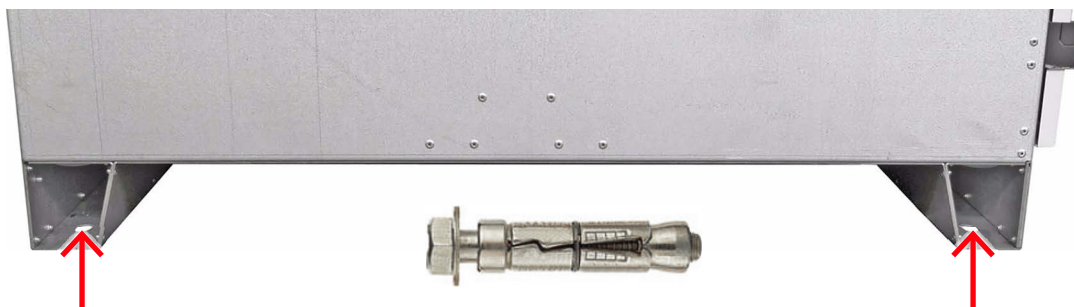

**Figure 41 – Fixing the cabinet to the floor**

PRODUCT	DOCUMENT KIND	DOCUMENT ID.	REV.	LANG.	PAGE
ACS1000A	User manual	3BHS213401 E01	N	en	70/160

## 6.6. Assembling and installing the air exhaust hood

This section applies to drives with an internal fan.

- Assemble and install the air exhaust hood as illustrated.
- Use the supplied screws.

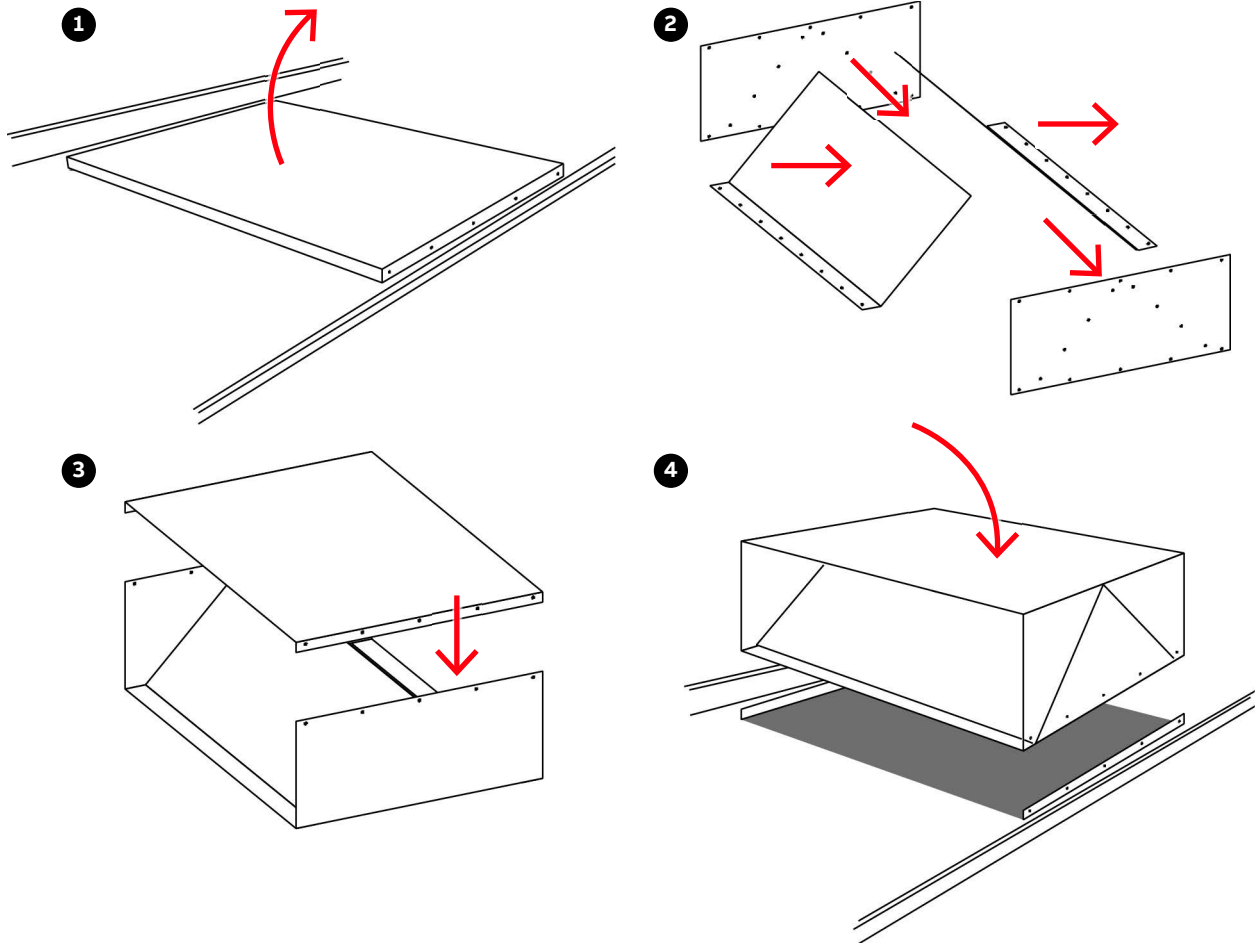

Figure 42 – Assembling and installing the air exhaust hood

## 6.7. Installing the redundant fan unit

This section applies to drives with a redundant fan unit.

- Included in delivery: mounting screws

**IMPORTANT!** Move the drive to its final location before you install the redundant fan unit.

1. Remove the top lifting rails (1, Figure 43) and then remove the cabinet access cover for the fan unit (2, Figure 43).

**IMPORTANT!** Keep the mounting bolts and Ripp-lock washers for the next step.

PRODUCT	DOCUMENT KIND	DOCUMENT ID.	REV.	LANG.	PAGE
ACS1000A	User manual	3BHS213401 E01	N	en	71/160

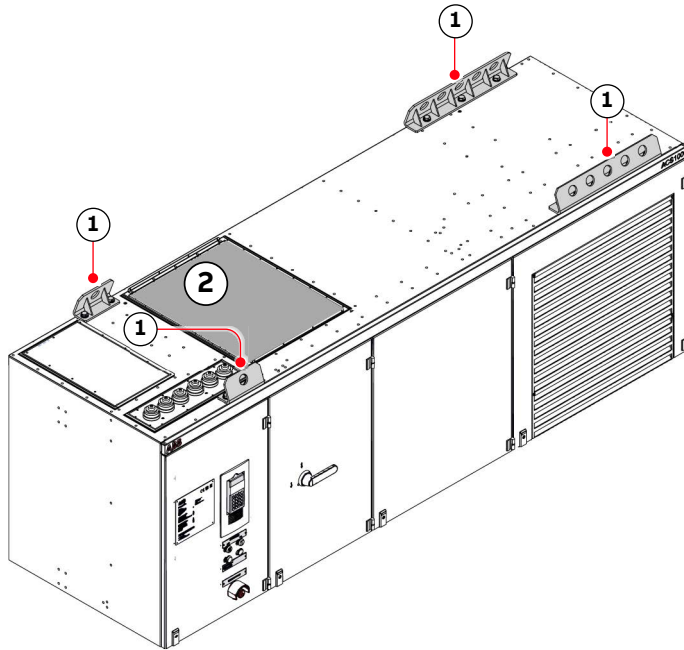
**Key**

(1) Top lifting rails

(2) Fan access cover

**Figure 43 – Redundant fan unit – Removing lifting rails (1) and fan access cover (2)**

2. Grease and reinstall the mounting bolts and Ripp-lock washers from the lifting rails in the drive cabinet roof.

**NOTICE** Tighten the bolts to a torque of 204 Nm to preserve the IP rating of the drive.

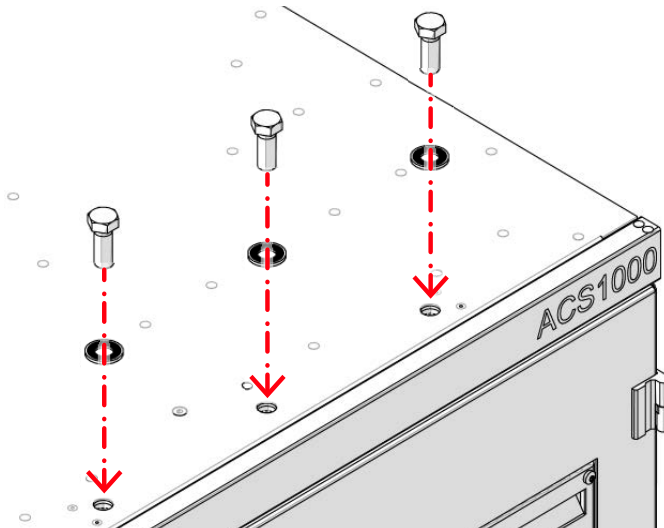

3. Attach the lifting gear to the rotating eye bolts (3, Figure 44) of the redundant fan unit (1, Figure 44).

**CAUTION!** The redundant fan weighs approximately 300 kg.

4. Orientate the redundant fan unit with the cable pointing to the left (2, Figure 44).
5. Lift the redundant fan unit above the cabinet.
6. Before you lower the redundant fan unit onto the cabinet roof, check that the gasket between cabinet roof and redundant fan unit is properly placed.

PRODUCT	DOCUMENT KIND	DOCUMENT ID.	REV.	LANG.	PAGE
ACS1000A	User manual	3BHS213401 E01	N	en	72/160

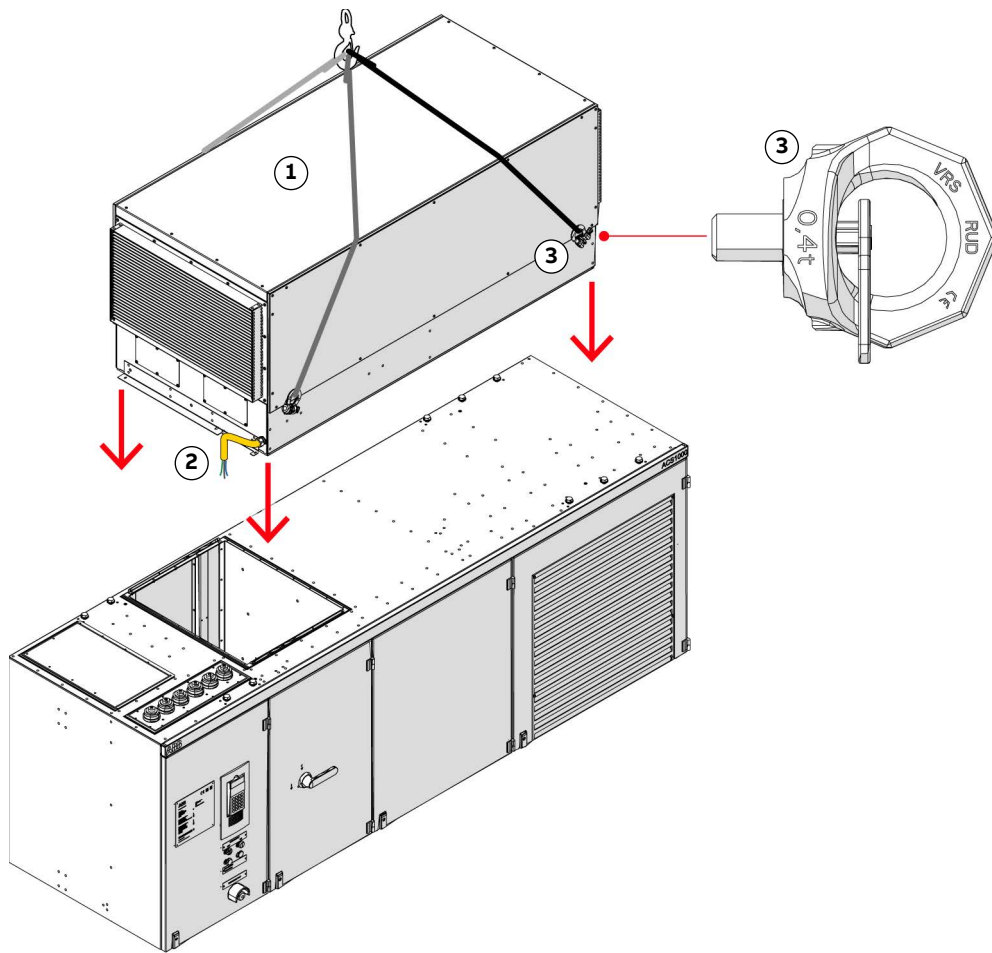
**Key**

- (1) Redundant fan
- (2) Cables
- (3) Rotating eye bolt

**Figure 44 – Redundant fan unit – Installation**

PRODUCT	DOCUMENT KIND	DOCUMENT ID.	REV.	LANG.	PAGE
ACS1000A	User manual	3BHS213401 E01	N	en	73/160

7. Fasten the redundant fan unit on both sides to the cabinet roof.

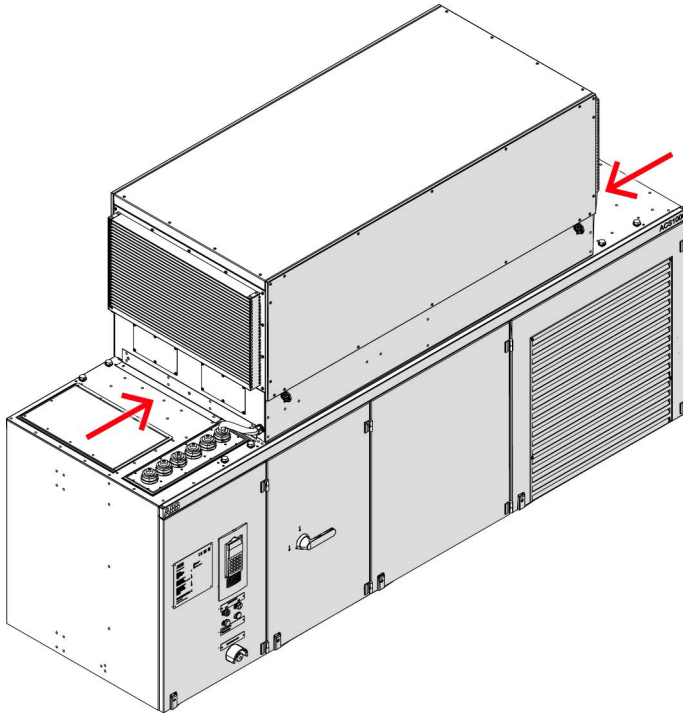

8. Attach the sound absorbing panels on the right side of the redundant fan unit.  
Recommended sequence: 1, 2, and 3.

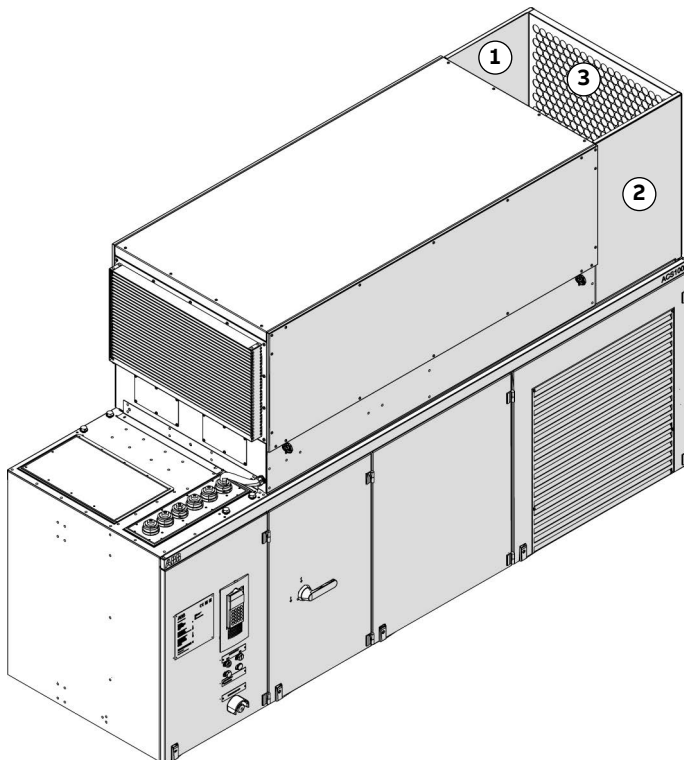

**Figure 45 – Recommended sequence for attaching the sound absorbing panels on the right side of the fan unit**

PRODUCT	DOCUMENT KIND	DOCUMENT ID.	REV.	LANG.	PAGE
ACS1000A	User manual	3BHS213401 E01	N	en	74/160

9. Route the power supply cable of the redundant fan unit with the transformer and motor cables into the cabinet,
10. Attach the sound absorbing panels on the left side of the redundant fan unit.  
Recommended sequence: 1, 2, and 3.

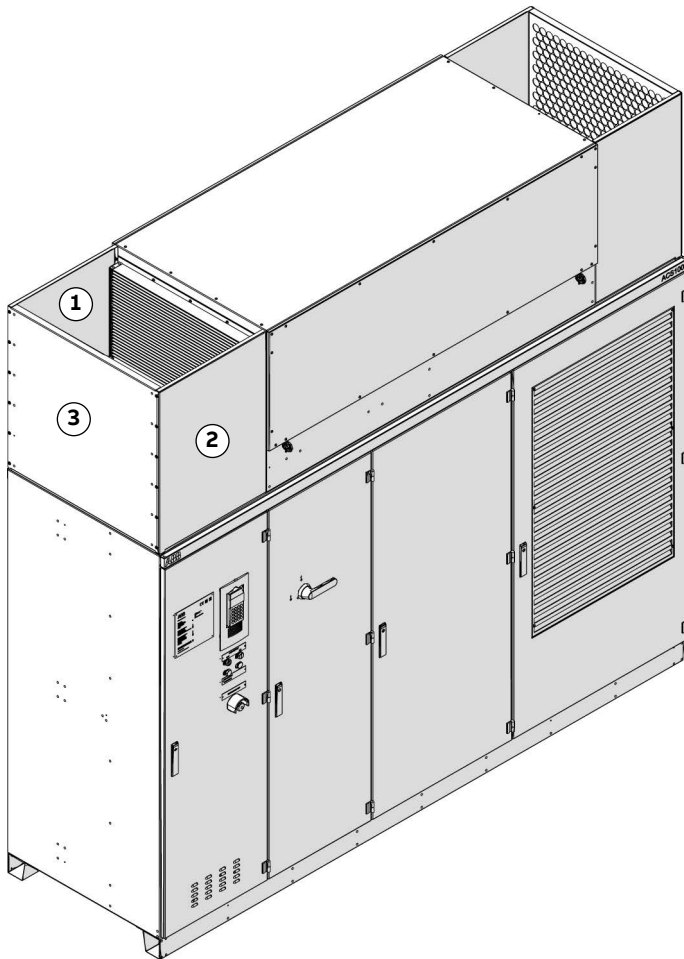

**Figure 46 – Recommended sequence for attaching the sound absorbing panels on the left side of the fan unit**

11. Continue with the electrical installation of the power supply cable.  
See [7.7 Power supply cable for redundant fan unit on page 96](#).

PRODUCT	DOCUMENT KIND	DOCUMENT ID.	REV.	LANG.	PAGE
ACS1000A	User manual	3BHS213401 E01	N	en	75/160

## 7. Electrical installation

### 7.1. Safety



#### **! DANGER**

**Hazardous voltage!** Improper work can result in DEATH or life-threatening injury.

- The electrical installation must be carried out by qualified personnel according to the site and equipment requirements, and the relevant electrical codes.
- When the electrical installation is completed, the main and auxiliary power supply to the drive must not be switched on without the consent of the ABB commissioning personnel.
- Take appropriate measures to prevent main and auxiliary power supply being switched on during installation.

### 7.2. Overview of installation work

The electrical installation includes the following wire and cable connections:

- “Power cables, ground cables and equipotential bonding conductor”, page 80
- “Auxiliary power, control and serial communication cables”, page 91
- “Power supply cable for redundant fan unit”, page 96

### 7.3. Cable requirements

For information on the requirements for power cables, ground cable, and equipotential bonding conductor, see:

- “Power cable specification”, 3BHS189994 E01
- “Power cables engineering guideline”, 3BHS542290 E01

For information on the requirements for the auxiliary power cable and the control cables, see the “Auxiliary power and control cables guideline”, 3BHS813742 E01.

#### 7.3.1. Additional cable requirements for a UL certified drive

The UL standard has the following additional requirements for field connection cables on the power input and output side of a UL certified drive:

- Maximum diameter of 177 mm<sup>2</sup> (350 kcmil), which is determined by the ampacity that is required for a minimum temperature rating of 60 °C
- Connection angle of 30°, which is provided by the customer connection plate (see [7.5.1.2 Orientation of cables with 2-hole cable lugs on terminal busbar on page 81](#))
- Termination with 2-hole NEMA pad cable lug (prevents rotation)
- Minimum tightening torque of 36.7 Nm (325 lbf-in) for the terminals

PRODUCT	DOCUMENT KIND	DOCUMENT ID.	REV.	LANG.	PAGE
ACS1000A	User manual	3BHS213401 E01	N	en	76/160

## 7.4. Cable entries

The cables can be entered through the roof or the floor of the cabinet.

The cabinet is equipped with one of the following cable entries:

- Cable entry with EMC plates
- Cable entry with sealing modules, type 1
- Cable entry with sealing modules, type 2
- Cable entry with cable glands

For information on location and dimensions, see “Appendix C - Mechanical drawings”.

### 7.4.1. Cable entry with EMC plates

- **Usage:**
  - Power cables, ground cables and bonding conductors
  - Auxiliary power cables and control cables
- **Included in delivery:** galvanized plate with net-like EMC sleeves (1 in Figure 47) and sealing grommets (2)

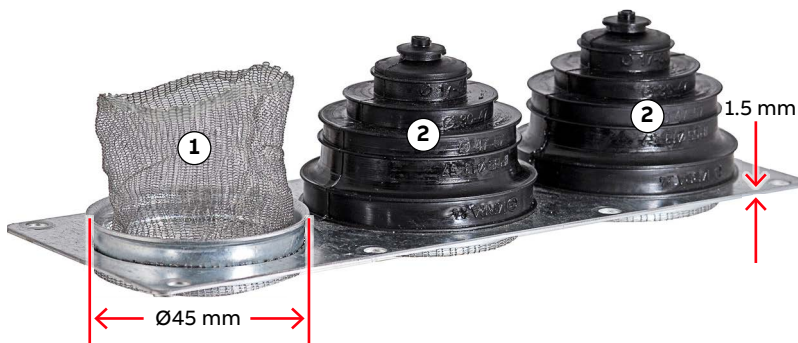

#### Key

- (1) EMC sleeves
- (2) Sealing grommets

**Table 11:**

#### Figure 47 – EMC plate example

- EMC cushions (1, Figure 48) on the underside of the EMC plate if the cable entry is used for control cables.

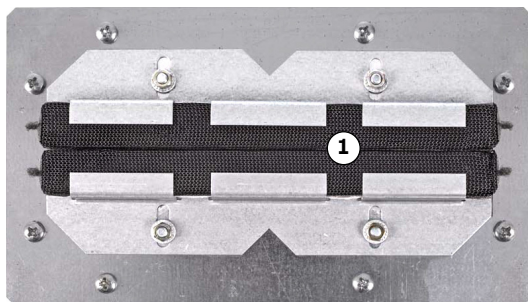
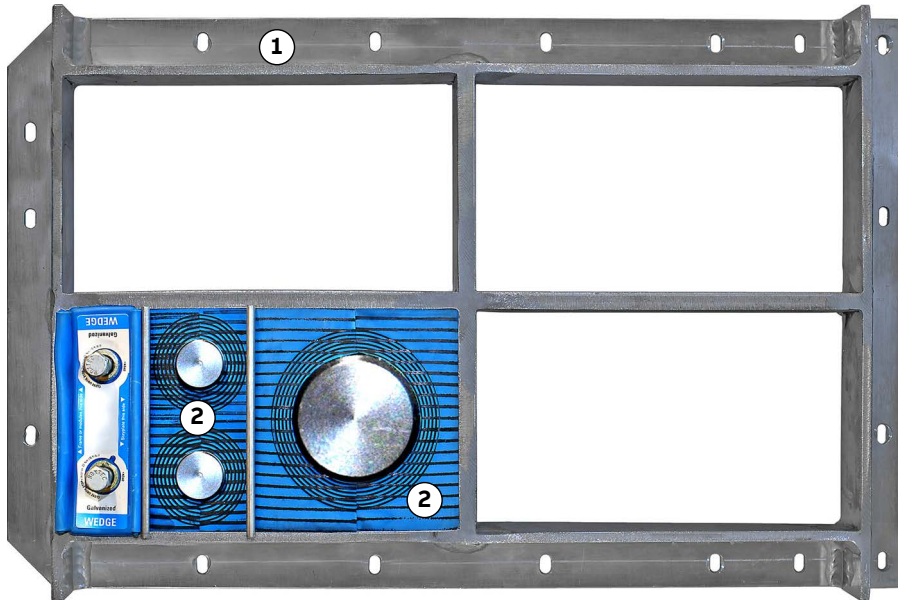

**Figure 48 – EMC cushion**

PRODUCT	DOCUMENT KIND	DOCUMENT ID.	REV.	LANG.	PAGE
ACS1000A	User manual	3BHS213401 E01	N	en	77/160

### 7.4.2. Cable entry with type 1 sealing modules

- **Usage:** power cables, ground cables and bonding conductors
- **Included in delivery:** cable entry frame (1, Figure 49)
- **Not included in delivery:** sealing modules (2, Figure 49), accessories and tools



#### Key

- (1) Cable entry frame
- (2) Sealing modules

**Table 12:**

**Figure 49 – Type 1 sealing modules (example)**

### 7.4.3. Cable entry with type 2 sealing modules

- **Usage:** auxiliary power cables and control cables
- **Included in delivery:** frame (1, Figure 50)
- **Not included in delivery:** tools, accessories and EMC sealing modules (2, Figure 50)
- **Supplier:** Roxtec AB (<https://www.roxtec.com/>)

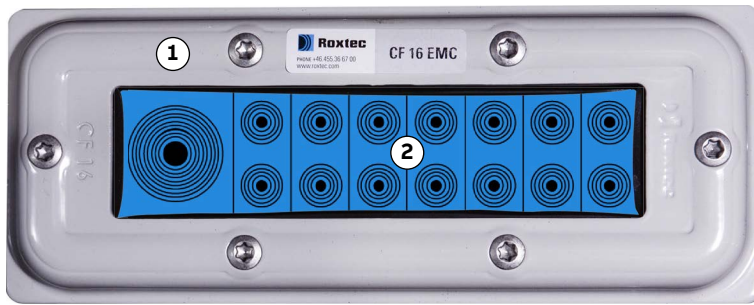
**Key**

- (1) Frame
- (2) EMC sealing modules

**Table 13:****Figure 50 – Type 2 sealing modules example**

PRODUCT	DOCUMENT KIND	DOCUMENT ID.	REV.	LANG.	PAGE
ACS1000A	User manual	3BHS213401 E01	N	en	79/160

### 7.4.4. Cable entry with cable glands

- **Usage:**
  - Power cables, ground cables and bonding conductors
  - Auxiliary power cables and control cables
- **Included in delivery:** undrilled plate for cable glands
- **Not included in delivery:** cable glands, tools and accessories

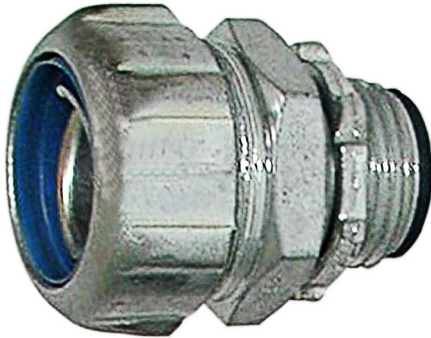

Figure 51 – Cable entry with cable glands

## 7.5. Power cables, ground cables and equipotential bonding conductor

See the layout drawings in “Appendix C - Mechanical drawings” for information on:

- Project-specific cable entry
- Distance between point of cable entry and terminals
- Busbar and fastening hole dimensions
- Busbar designations

See “Appendix D - Wiring diagrams” for information on conventions for cross-reference and device identification.

### 7.5.1. Preparing the cable entry and the cables

#### **NOTICE**

**Risk of damage or malfunction!** Waste inside the cabinet can cause damage or malfunction.

- If possible, DO NOT cut cables inside the terminal compartment
- Remove any waste that was accidentally dropped in the cabinet

### 7.5.1.1. Maximum number of cables per phase

The maximum number of cables that can be used per phase depends on the type of the drive and its nominal voltage.

**Table 14 – Maximum number of cables per phase**

ACS1000A type	2.3 kV nominal voltage	3.3 kV nominal voltage	4.0 kV nominal voltage
A1	1 cable per phase	1 cable per phase	1 cable per phase
A2	2 cables per phase <sup>1</sup>	1 cable per phase	1 cable per phase
A3	2 cables per phase <sup>1</sup>	2 cables per phase	1 cable per phase

<sup>1</sup>Depending on the cable entry type in the 24-pulse variant, you might be limited to one cable per phase. For more information, see the 'Cable entry and connection drawing' in "Appendix C - Mechanical drawings".

### 7.5.1.2. Orientation of cables with 2-hole cable lugs on terminal busbar

**IMPORTANT!** For drives with UL certification, 2-hole NEMA pad cable lugs (shown) are mandatory for the terminal busbar connections.

The indication holes (1, 3, Figure 52) on the factory-installed busbars show the cable lug orientation with respect to the cable entry, ie, for top cable entry, the hole is at the top of the busbar and for bottom cable entry, the hole is at the bottom of the busbar.

Use the indication holes to verify the cable orientation on-site. If the orientation does not match the location of the cable entry, you need to unbolt, flip, and then re-attach the busbars with the bolts tightened to a torque of 30 Nm.

For details on the cable entry and high voltage cable termination, see the relevant cable entry and connection diagrams (3BHS853475 E01 or 3BHS853475 E02) in "Appendix C - Mechanical drawings".

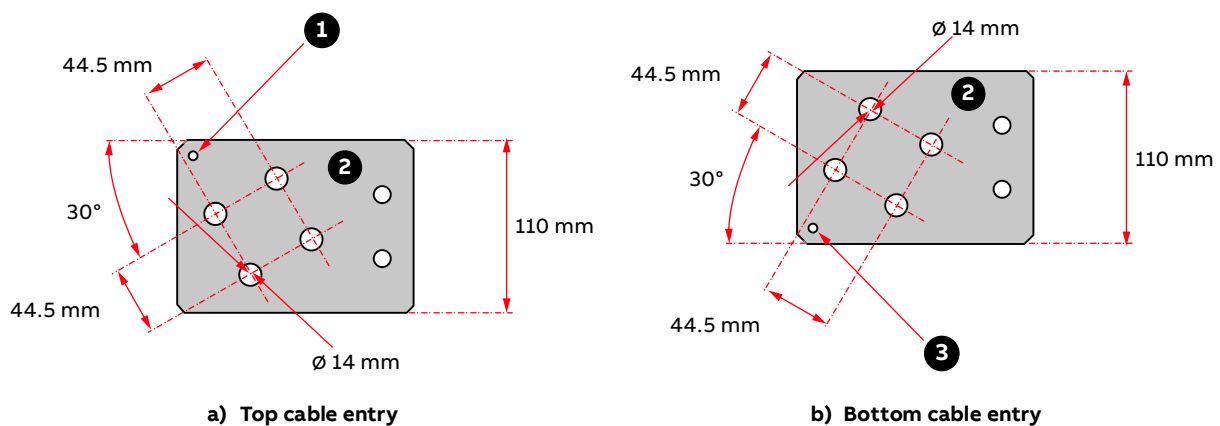
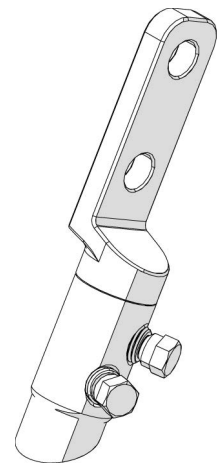

#### Key

- (1) Indication hole on top
- (2) Terminal busbar
- (3) Indication hole on bottom

**Figure 52 – Cable termination – busbar thickness is 5 mm**

PRODUCT	DOCUMENT KIND	DOCUMENT ID.	REV.	LANG.	PAGE
ACS1000A	User manual	3BHS213401 E01	N	en	81/160

### 7.5.1.3. Determining the cable length

1. Determine the required length of a cable between the point of entry and the connection point inside the cabinet.
2. Cut the cable to the required length before connection.

### 7.5.1.4. Splitting multi-core cables

This section applies to drives without an additional cabinet.

- Check the distance between point of cable entry and closest busbar.
- Check the cable diameter.
- If distance and cable diameter do not allow for the bending the cable inside the terminal compartment, separate the conductors outside of the terminal compartment.

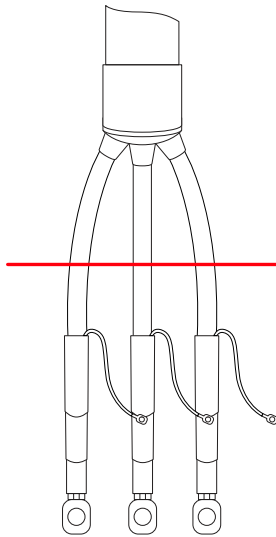

Continue with:

- [7.5.1.5 Preparing cables for EMC plates on page 83](#)
- [7.5.1.6 Preparing cables for cable entries with sealing modules on page 85](#)
- [7.5.1.7 Preparing cables for cable entries with cable glands on page 86](#)

### 7.5.1.5. Preparing cables for EMC plates

As a standard, the cabinet is delivered for cable entry through the roof of the terminal compartment. If cables are entered through the floor, swap entry plate and cover plate.

The orientation of the EMC plates is the same for cable entry through the roof and through the floor, ie, the sealing grommets face upwards.

1. Remove the grommets.

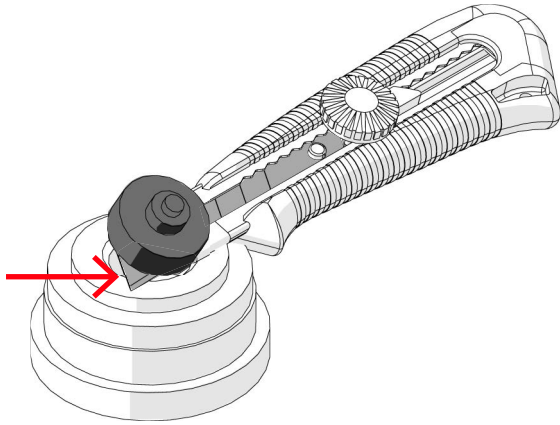

2. To ensure proper sealing, cut along the marking that corresponds to the cable diameter and slide the grommet onto the cable.

**IMPORTANT!** The grommet must fit tightly to prevent water entering the cabinet. The grommets can be discarded if cables are entered through the floor.

3. If necessary, remove the entry plate and push the cable through the entry holes.

4. Prepare the cables as illustrated.

- **A** in Figure 53 illustrates how cables with an outer cable screen or shield are prepared for EMC bonding with the metal enclosure of the cabinet.
- **B** in Figure 53 illustrates how cables without an outer screen or shield are prepared.

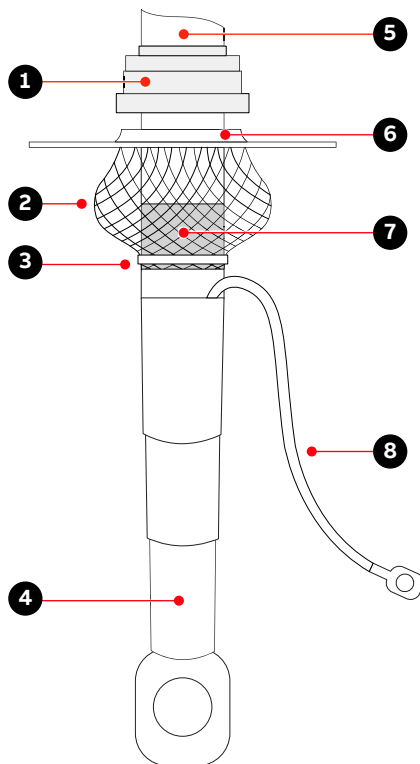

a) Cables with an outer screen or shield

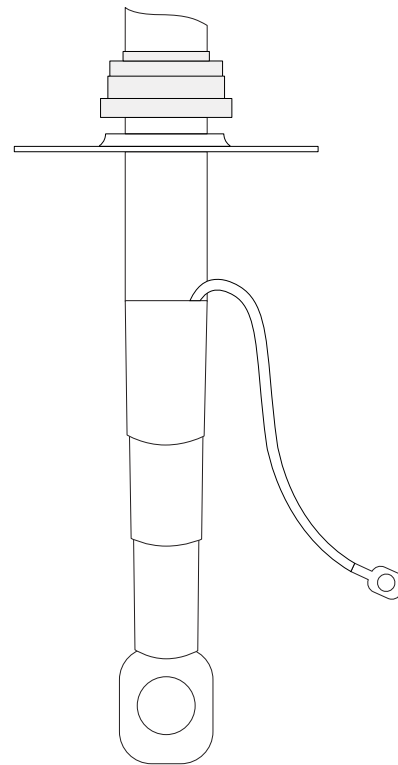

b) Cables without an outer screen or shield

**Key**

- |                                 |   |
|---------------------------------|---|
| (1) Grommet                     | (6) Entry plate   |
| (2) EMC sleeve                  | (7) Conductor insulation removed to expose cable shield |
| (3) Cable tie                   | (8) Cable screen extension to connect to the PE busbar  |
| (4) Heat-shrinkable termination |   |
| (5) Outer cable sheath          |   |

**Figure 53 – Preparing cables for EMC plates**

5. Route the equipotential bonding conductor through an unused hole in the entry plate.

**NOTE** – If all of the holes are used for conductors, route the equipotential bonding conductor together with a conductor.

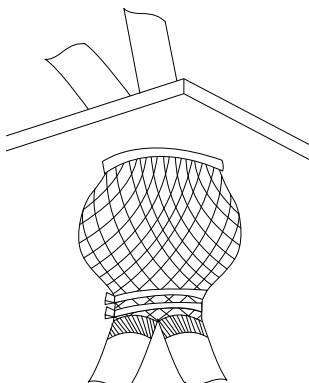

### 7.5.1.6. Preparing cables for cable entries with sealing modules

As a standard, the cabinet is delivered for cable entry through the roof of the terminal compartment. If cables are entered through the floor, swap entry plate and cover plate.

- Prepare cables with an outer cable screen or shield for EMC bonding with the metal enclosure of the cabinet as illustrated in Figure 54.

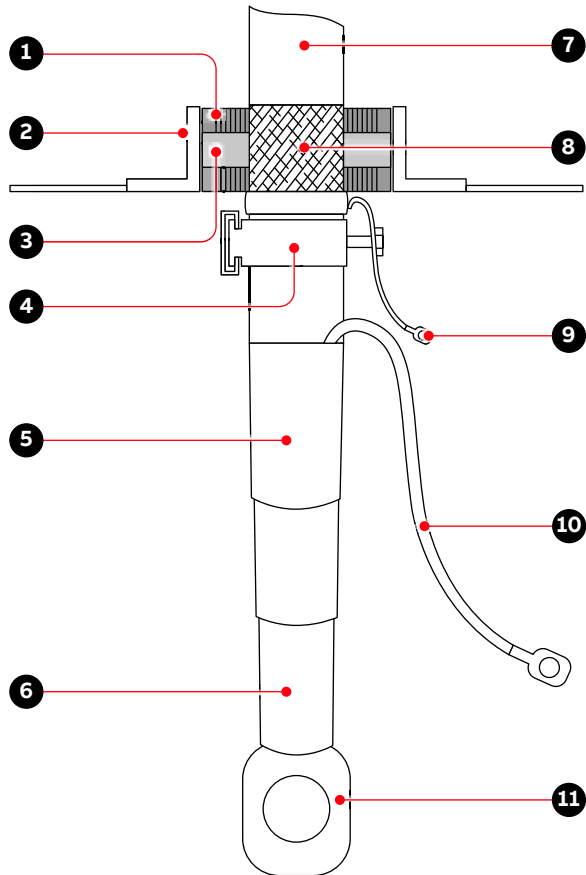

#### Key

- |                                       |   |
|---------------------------------------|---|
| (1) Sealing module                    | (8) Cable sheath removed to expose cable shield                             |
| (2) Frame                             | (9) Shield extension to be connected to PG busbar                           |
| (3) Conductive foil of sealing module | (10) Screen extension to be connected to the PG busbar                      |
| (4) Cable clamp                       | (11) Cable lug as specified by the cable supplier and suitable for M12 bolt |
| (5) Shrinkable sheath seal            |   |
| (6) Heat-shrinkable termination       |   |
| (7) Outer cable sheath                |   |

**Figure 54 – Preparing power cables for sealing modules**

- Install the sealing modules according to the instructions of the sealing module supplier.

### 7.5.1.7. Preparing cables for cable entries with cable glands

Prepare cables with an outer cable screen or shield for EMC bonding with the metal enclosure of the cabinet as illustrated in Figure 55.

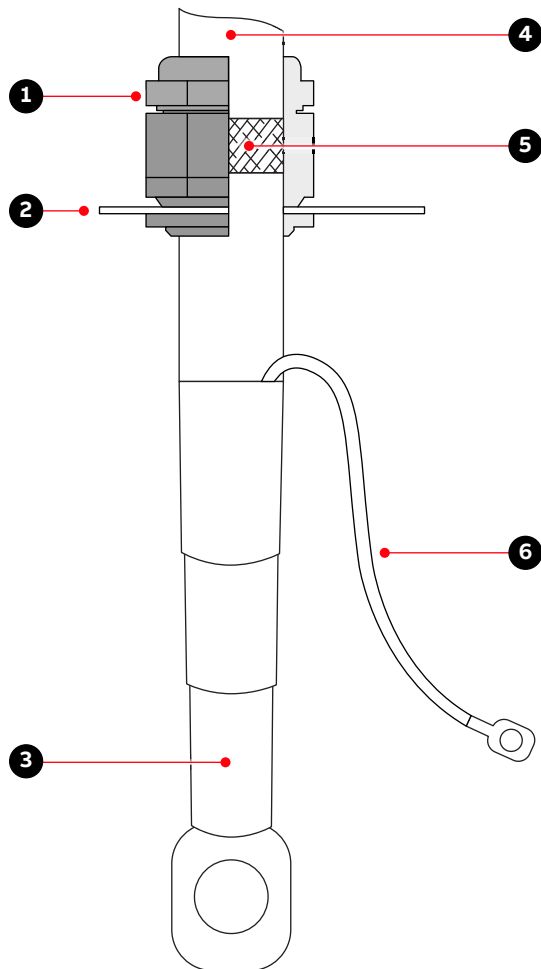

#### Key

- (1) Outer cable sheath
- (2) Cable gland
- (3) Conductor insulation removed to expose cable shield
- (4) Plate
- (5) Screen extension to be connected to PE ground busbar
- (6) Heat-shrinkable termination

**Figure 55 – Preparing power cables for cable glands**

PRODUCT	DOCUMENT KIND	DOCUMENT ID.	REV.	LANG.	PAGE
ACS1000A	User manual	3BHS213401 E01	N	en	86/160

## 7.5.2. Connecting the cables

### 7.5.2.1. Checking the cable insulation

- Check the insulation of each cable before connection and verify that the results are within the specification of the cable manufacturer.
- Leave the cable conductors unconnected at both ends until the commissioning engineer has given permission.

### 7.5.2.2. Connections



#### **CAUTION**

**Risk of flashover!** High voltages will be present in the terminal compartment. High voltages can cause flashover between conductors with different electric potential, and between a conductor and earth. When you route and connect the cables, maintain the following minimum clearances:

- 20 mm between cable lugs of conductors with different potentials
- 40 mm between cable lugs of conductors and the parts with earth potential

### Power and grounding cables

- Connect the following feeder cable conductors to the busbars with the fasteners and the tightening torque that are specified in [7.5.4 Bolted connections on page 90](#):
  - 1U1, 1V1, 1W1, 2U1, 2V1, 2W1 (12-pulse and 24-pulse drive, 2, Figure 56)
  - 3U1, 3V1, 3W1, 4U1, 4V1, 4W1 (24-pulse drive, 2, Figure 56)
- Connect the motor cables to busbars U2, V2, W2 (3, Figure 56).
- Connect the screens of all conductors and the shields of all cables to the PE ground busbar (4, Figure 56).
- Connect the equipotential bonding conductor to the PE ground busbar.
- Tie the cables to the strain relief rails (1, Figure 56).



For the phase numbering of the busbars, see the relevant cable entry and connection diagrams (3BHS853475 E01 for a 12-pulse drive 3BHS853475 E02 for a 24-pulse drive) in “Appendix C - Mechanical drawings”.

PRODUCT	DOCUMENT KIND	DOCUMENT ID.	REV.	LANG.	PAGE
ACS1000A	User manual	3BHS213401 E01	N	en	87/160

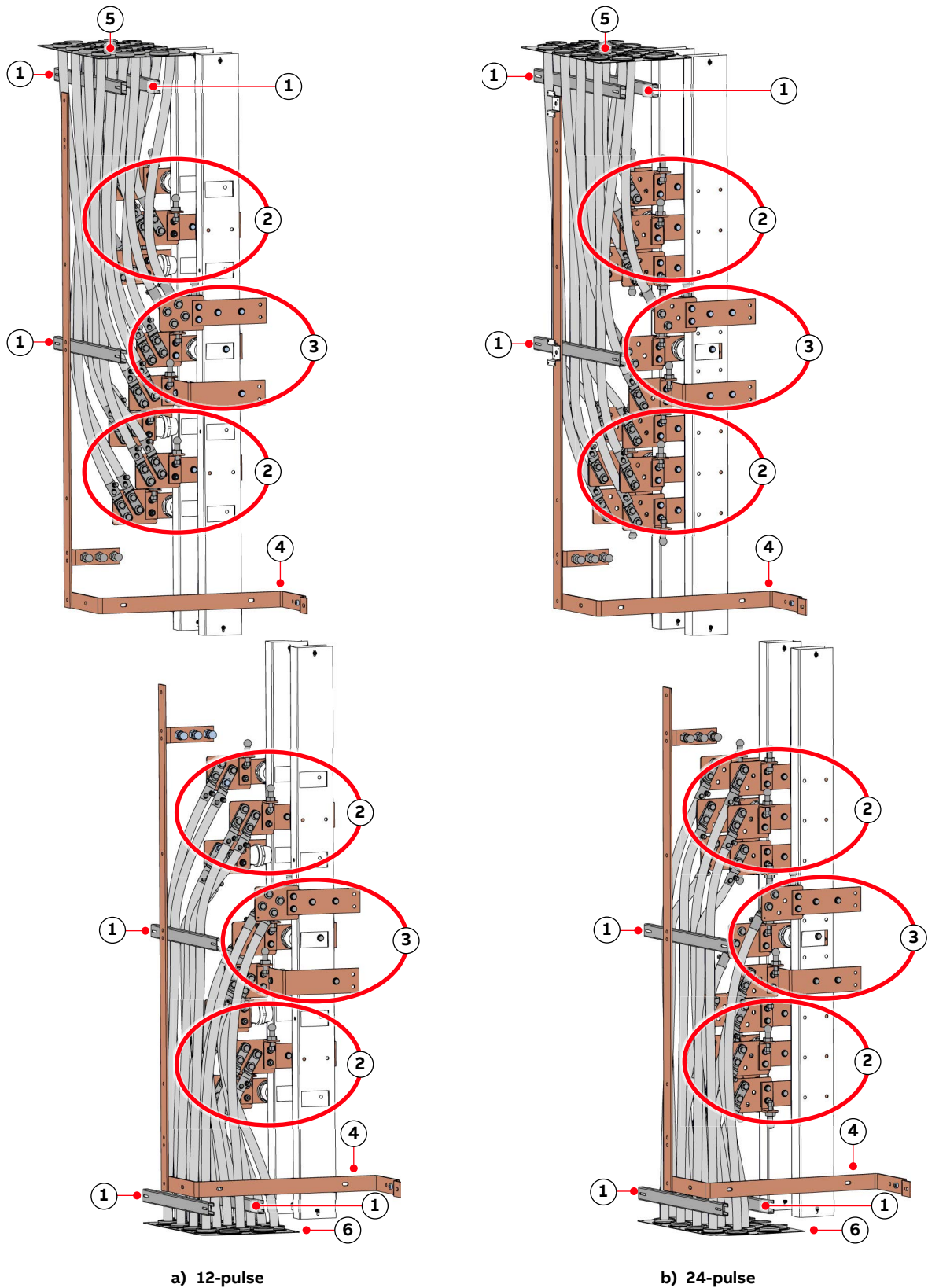
**Key**

- (1) Strain relief
- (2) Feeder cable busbars
- (3) Motor cable busbars

- (4) PE ground busbar
- (5) Top cable entry
- (6) Bottom cable entry

**Figure 56 – Power cable terminals**

PRODUCT	DOCUMENT KIND	DOCUMENT ID.	REV.	LANG.	PAGE
ACS1000A	User manual	3BHS213401 E01	N	en	88/160

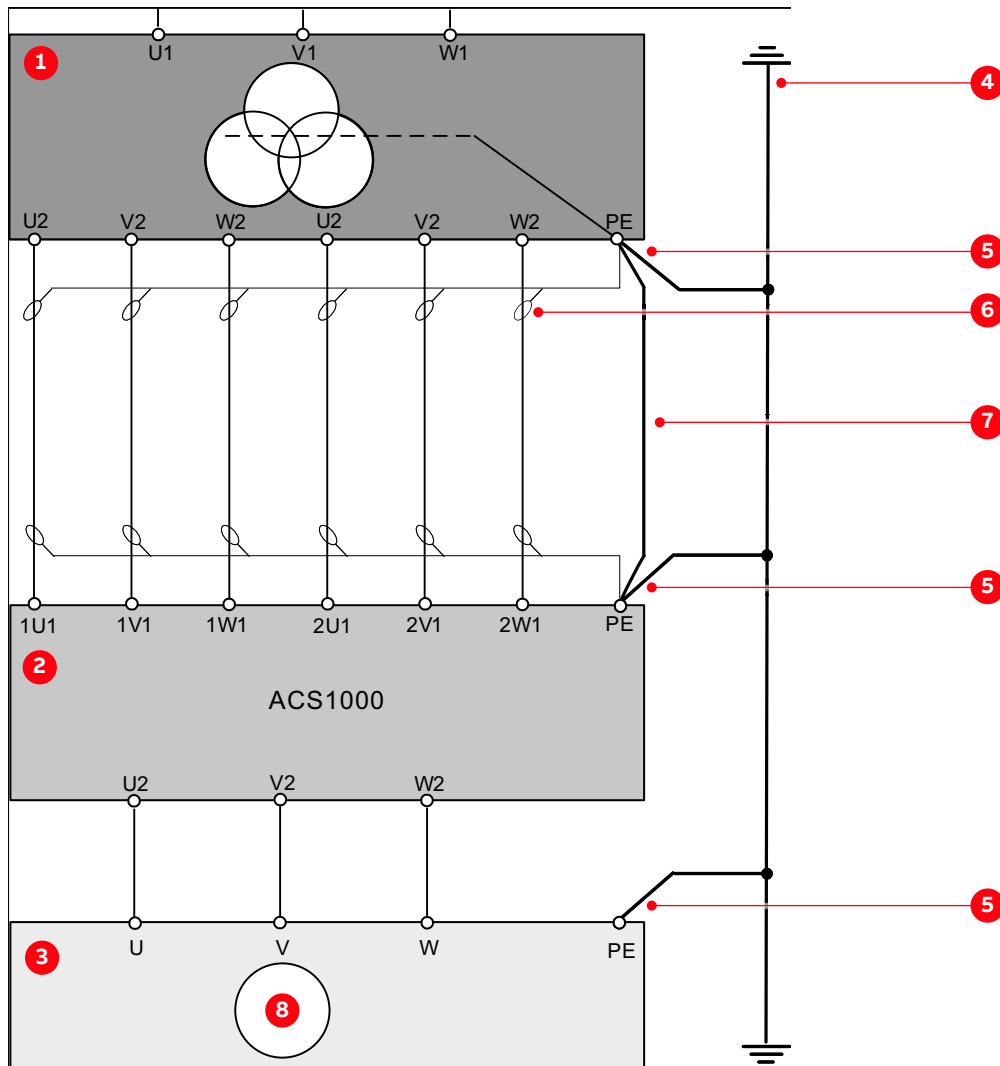
**Key**

- |                       |                                     |
|-----------------------|-------------------------------------|
| (1) Input transformer | (5) Ground cable                    |
| (2) Drive             | (6) Cable screen                    |
| (3) Motor             | (7) Equipotential bonding conductor |
| (4) Earth electrode   | (8) Motor                           |

**Figure 57 – Grounding the drive system****7.5.3. Minimum creepage distance between cable and busbar**

If spacers are used to connect a cable to a busbar, observe the minimum creepage distance. Depending on the comparative tracking index (CTI) of the insulation material of the cable, the following minimum creepage distances apply:

**Table 15 – Minimum creepage distance between cable and busbar**

	CTI	Minimum creepage distance
1	600	63 mm
2	400 - 600	71 mm
3	175 - 400	80 mm

## 7.5.4. Bolted connections

### 7.5.4.1. Material requirements

Use stainless steel bolts and nuts with the appropriate steel grade and property class for the connection (recommended: A2-70; designation according to ISO 3506).

NOTE – Nuts with bonded coating can be used as an alternative to uncoated stainless steel nuts.

### 7.5.4.2. Connection type

The following connection type is recommended when a cable lug (4, Figure 58) is connected to a busbar:

- Spring washer (1, Figure 58) and flat washer (2, Figure 58) on each side of the busbar (3, Figure 58).

NOTE – Other washers can be used, provided they maintain the required contact pressure.

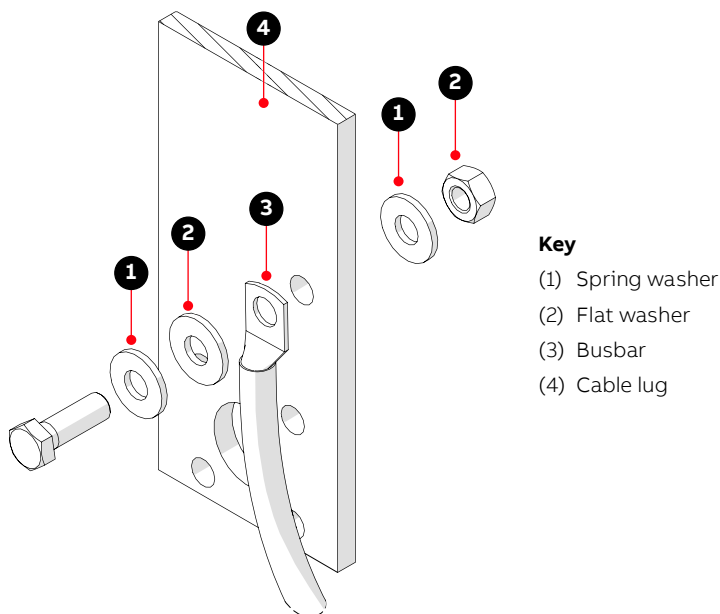

Figure 58 – Bolted busbar connections

### 7.5.4.3. Lubrication

If stainless steel bolts and nuts are used, lubricate the thread and head contact surface of the bolt using recommended pasts, eg, Molykote D paste.

NOTE – If a coated nut (eg, with bonded molybdenum-disulfide [MoS<sub>2</sub>] coating) is used, the connection does not need to be lubricated.

### 7.5.4.4. Tightening torque

For bolted connections, use the recommended nominal torque for the bolt size (M10 to M14) that you use.

For drives with UL certification, the minimum tightening torque for bolts to attach the two-hole NEMA pad cable is 37.6 Nm.

PRODUCT ACS1000A	DOCUMENT KIND User manual	DOCUMENT ID. 3BHS213401 E01	REV. N	LANG. en	PAGE 90/160
---------------------	------------------------------	--------------------------------	-----------	-------------	----------------

## 7.6. Auxiliary power, control and serial communication cables

See the layout drawings in “Appendix C - Mechanical drawings” for information on:

- Project-specific cable entry
- Dimensions between point of cable entry and terminals

See “Appendix D - Wiring diagrams” for information on:

- Conventions for cross-references and device identification
- Terminal designations

### 7.6.1. Preparing the cable entry and the cables

#### 7.6.1.1. Determining the cable length

1. Determine the required length of a cable between the point of entry and the connection point (1, Figure 59) inside the cabinet.
2. Cut the cable to the required length before connection.

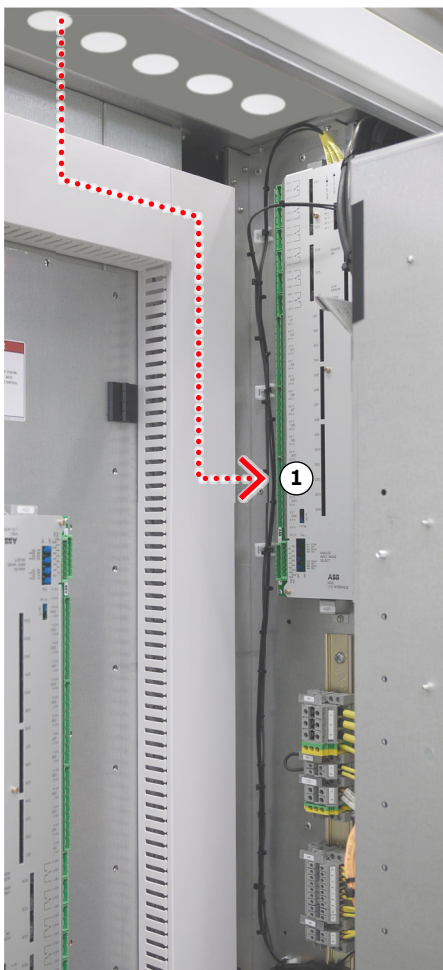

a) Top



b) Bottom

Figure 59 – Cable entry

PRODUCT	DOCUMENT KIND	DOCUMENT ID.	REV.	LANG.	PAGE
ACS1000A	User manual	3BHS213401 E01	N	en	91/160

### 7.6.1.2. Preparing cables for EMC plates

1. Remove the grommets.
2. To ensure proper sealing, cut along the marking that corresponds to the cable diameter and slide the grommet onto the cable.

**IMPORTANT!** The grommet must fit tightly to prevent water entering the cabinet. The grommets can be discarded if cables are entered through the floor

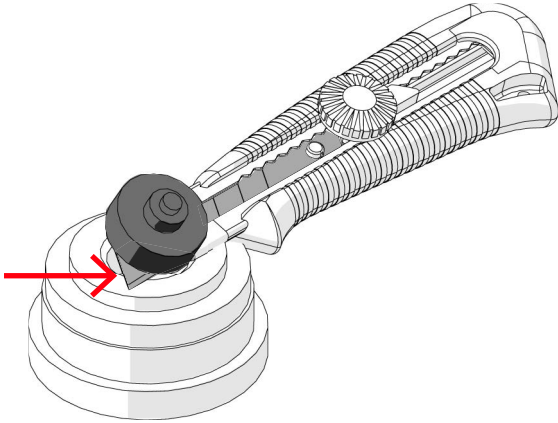

3. If necessary, remove the entry plate and pull the cable through the entry holes.
4. Loosen the screws of the EMC cushion brackets and push the cushions apart (arrows).



5. If the outer cable screen is non-conductive, cut open the cable screen in the middle of the stripped area (1), pull the screen ends over the cable insulation (2) and then connect the screen ends with a continuous conducting foil (3).

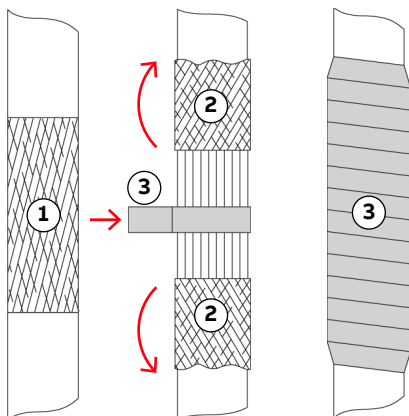

6. Pull the cables through the EMC cushions.
7. Push the cushions together so they fit tightly around the bare screen and tighten the screws.

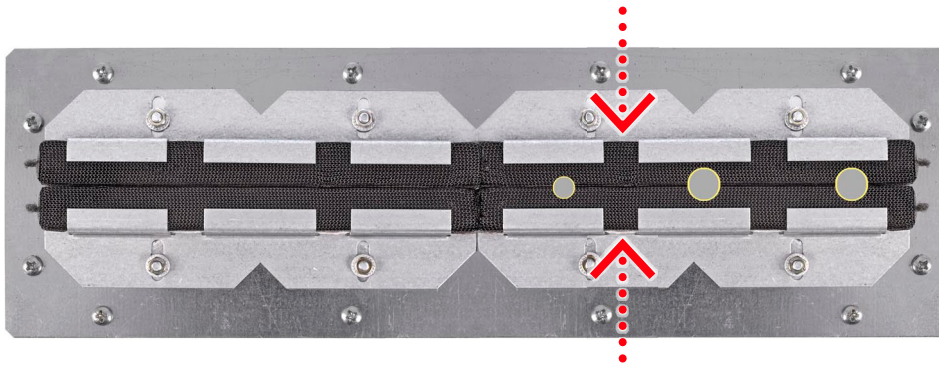

### 7.6.1.3. Preparing cables for cable entries with sealing modules

1. Unscrew the frame and remove the sealing modules.  
For information on removing and installing the sealing modules and using the compression wedge (1), see “Appendix A - Additional manuals”.

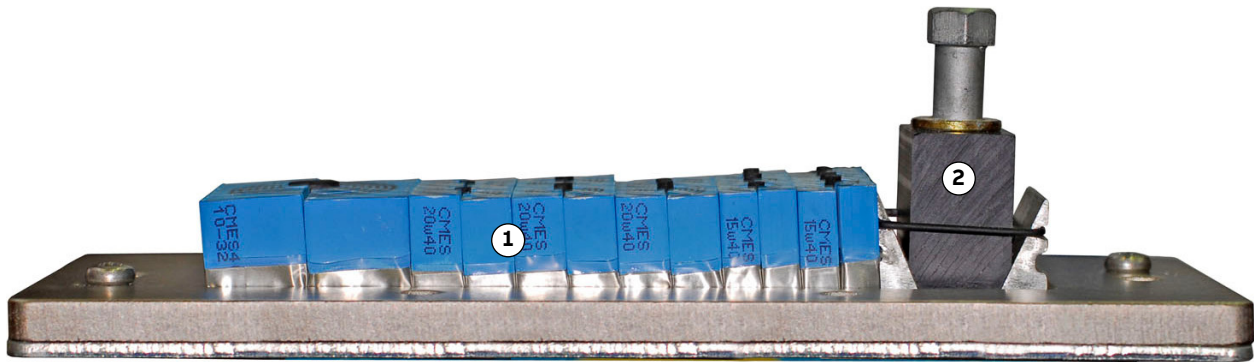

#### Key

- (1) Sealing modules
- (2) Compression wedge

**Figure 60 – Frame with sealing modules**

PRODUCT	DOCUMENT KIND	DOCUMENT ID.	REV.	LANG.	PAGE
ACS1000A	User manual	3BHS213401 E01	N	en	93/160

2. Prepare the cables with an outer cable screen for EMC bonding with the metal enclosure of the cabinet as illustrated in Figure 61.

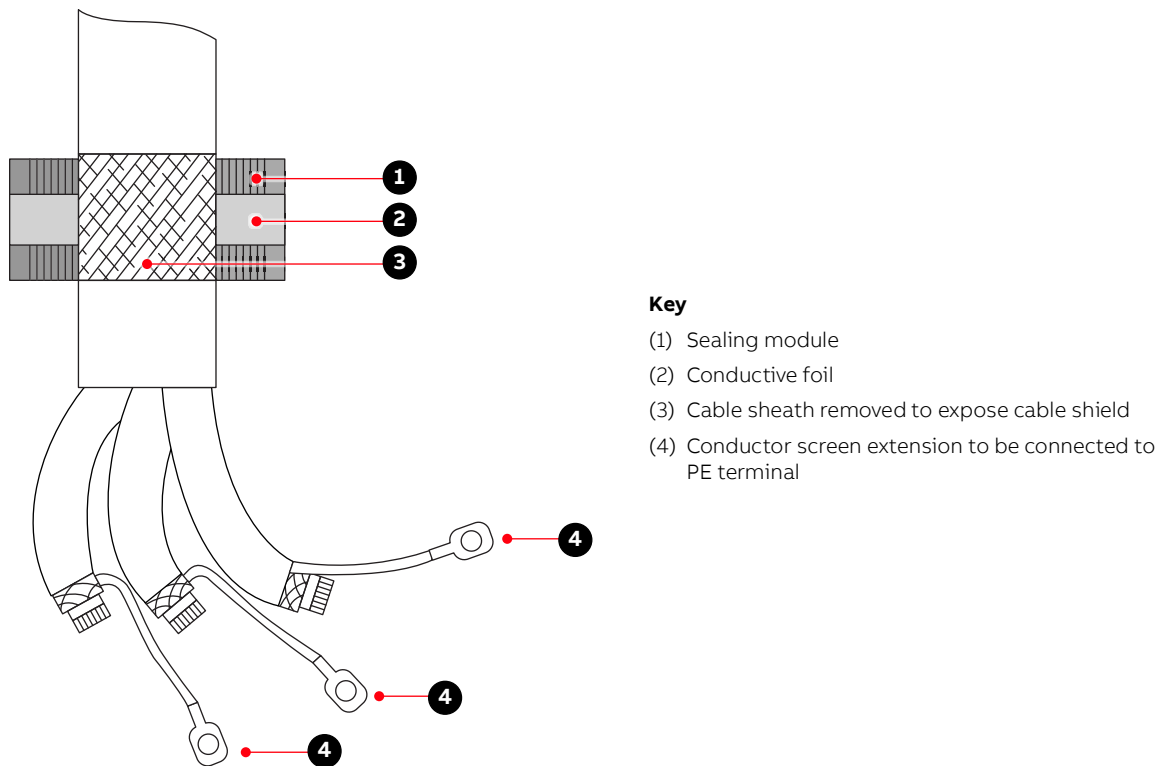

Figure 61 – Preparing control cables for sealing modules

#### 7.6.1.4. Preparing cables for cable entries with cable glands

- Prepare the cables with an outer cable screen for EMC bonding with the metal enclosure of the cabinet as illustrated in Figure 62.

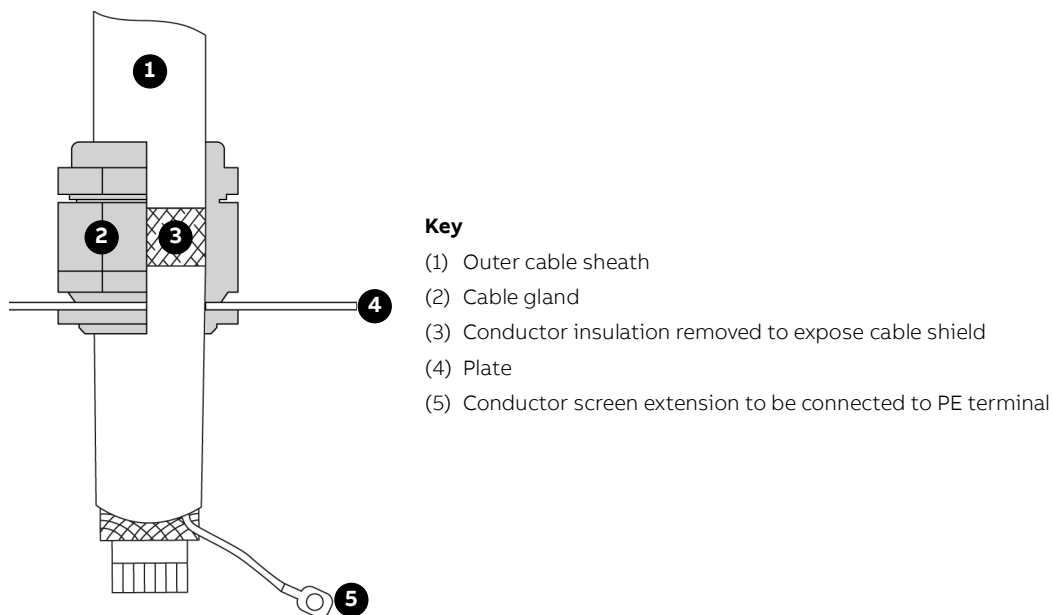

Figure 62 – Preparing control cables for cable glands

## 7.6.2. Connecting the cables

### 7.6.2.1. IOEC modules

- Connect the cables for digital and analog input and output signals to the distribution terminals.

### 7.6.2.2. Conductors

- If a twisted pair cable is used, leave the unshielded cable ends twisted until they reach the terminals.
- Leave unshielded conductor ends as short as possible (not longer than 50 mm).

### 7.6.2.3. Cable shields

- Connect the shield of serial communications cables to the fieldbus adapter.
- Connect the overall shield and the individual shields of the encoder cable to the separate shield grounding bracket (2, Figure 63).

**IMPORTANT!** DO NOT connect the shields directly to the encoder adapter (1, Figure 63).

To accommodate encoder cables of different diameters, ground clamps (3, Figure 63) of different sizes are supplied.

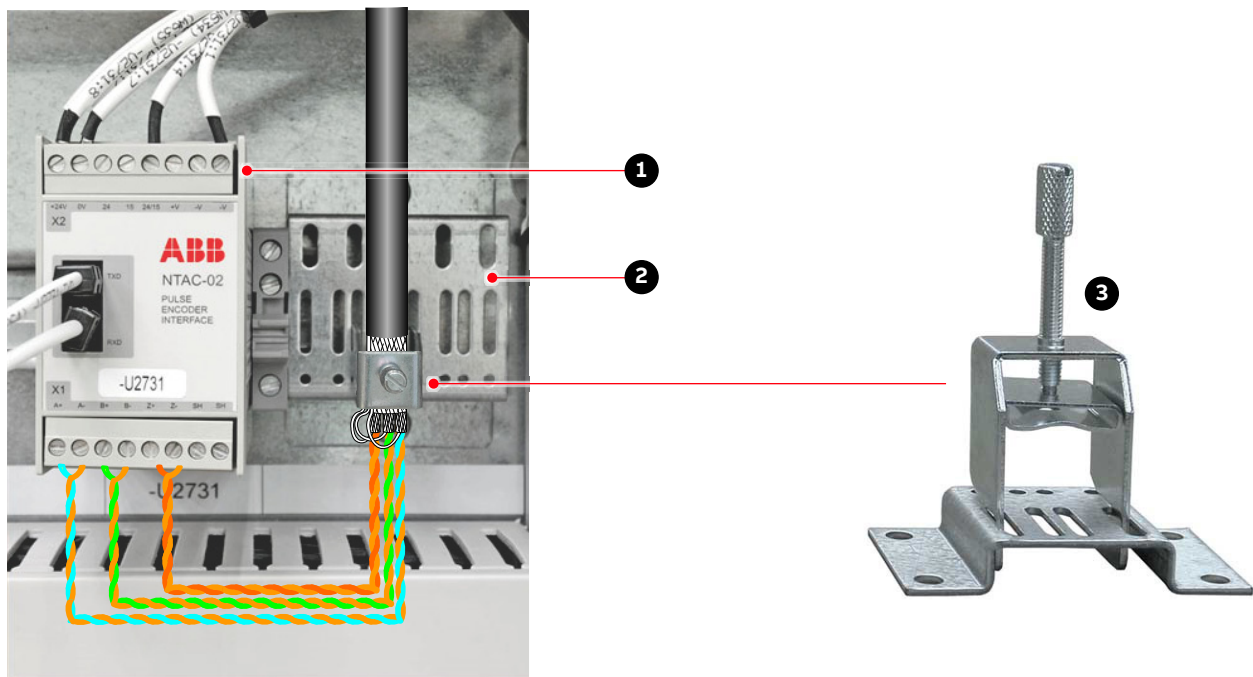

#### Key

- (1) Encoder adapter
- (2) Shield ground bracket
- (3) Grounding clamp

**Figure 63 – Shield grounding point for encoder cable**

PRODUCT	DOCUMENT KIND	DOCUMENT ID.	REV.	LANG.	PAGE
ACS1000A	User manual	3BHS213401 E01	N	en	95/160

## 7.7. Power supply cable for redundant fan unit

This section applies to drives that are equipped with the optional redundant fan.

For information on the cable connection, see “Appendix D - Wiring diagrams”.

1. Enter the pre-fabricated multi-core cable into the cabinet as close as possible to the redundant fan unit and according to the type of control cable entry used.

For more information on cable entry, see:

- [7.6.1.2 Preparing cables for EMC plates on page 92](#)
- [7.6.1.3 Preparing cables for cable entries with sealing modules on page 93](#)
- [7.6.1.4 Preparing cables for cable entries with cable glands on page 94](#)

The braided metal cable sleeve (1 in Figure 64) does not have to be grounded at the point of entry. If necessary, seal the gaps according to the type of cable entry used.

2. Route the wires to the terminals (2 and 3, Figure 64) as illustrated.

NOTE – Connection 3 in Figure 64 depends on the type of fan, eg, AC or EC.

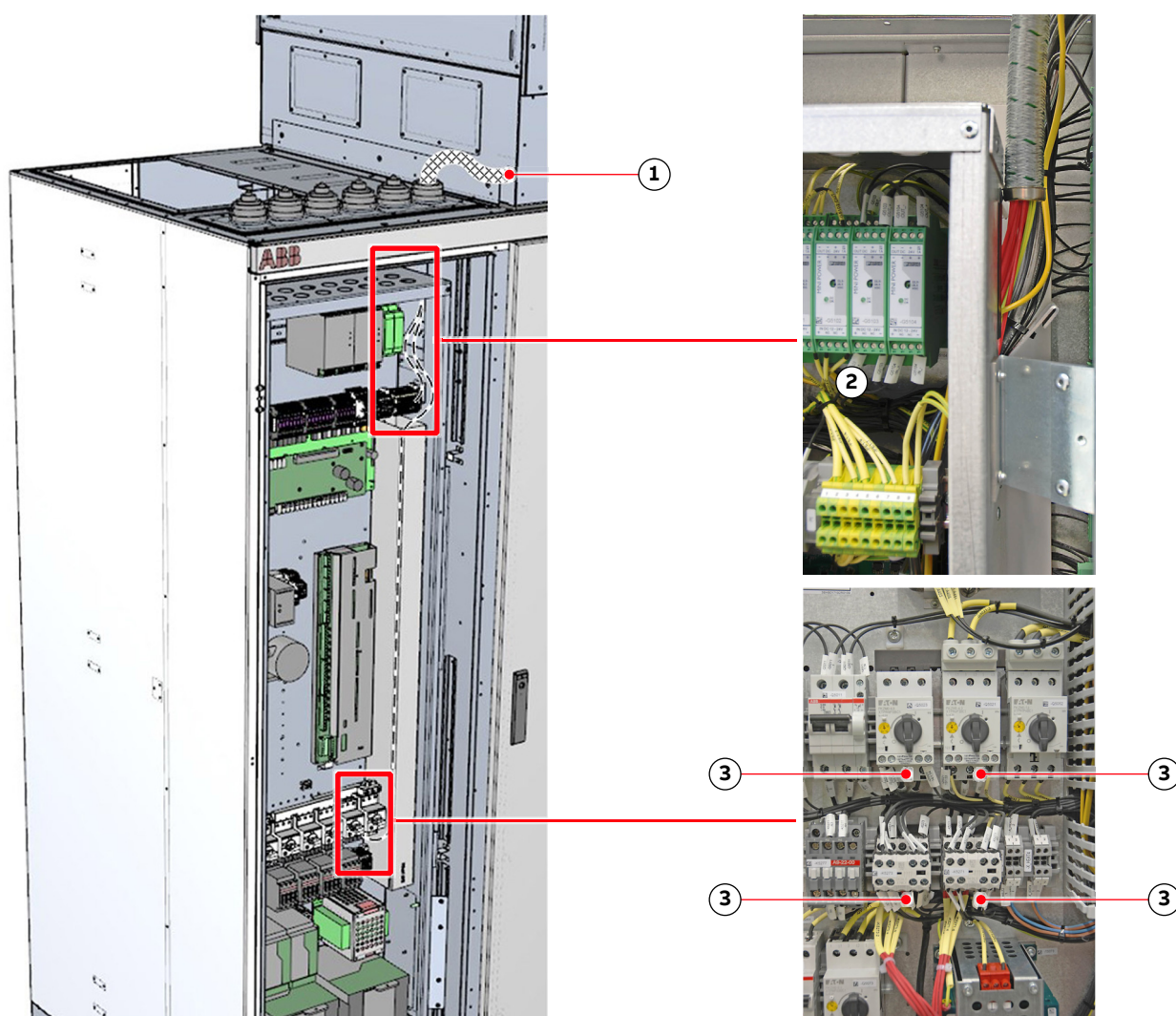
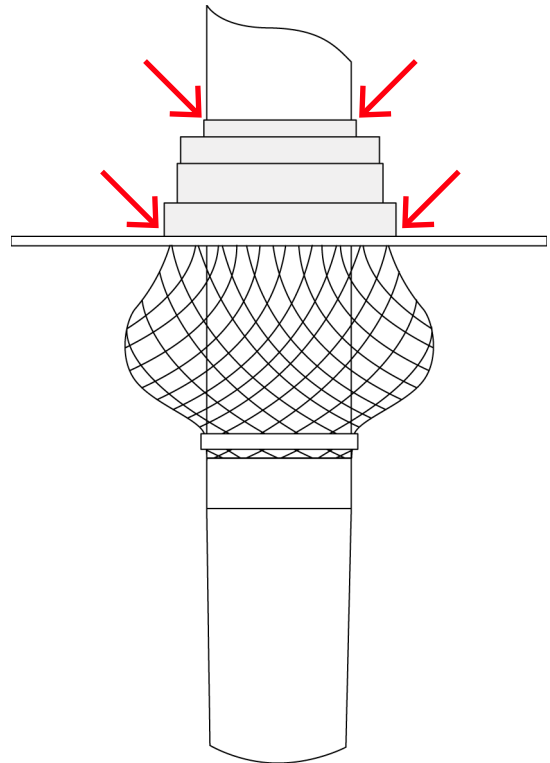

**Figure 64 – Routing, connecting the cable of the redundant fan unit**

3. Connect the wires according to the terminal number on the marker sleeves.

## 7.8. Final checks

- ▶ Check that the entry plates are properly secured.
- ▶ If you used EMC entry plates check that the grommets fit tightly (arrows) to prevent water entering the cabinet.
- ▶ If required, seal gaps with silicone.



## 8. Commissioning

### 8.1. Overview

The following sections provide an overview of the commissioning process for your drive.

#### 8.1.1. Required qualification

Commissioning, parameter adjustments and functional tests must be carried out only by qualified commissioning personnel that have been certified by ABB.

#### 8.1.2. Commissioning procedure

Information on the commissioning procedure and the start conditions for commissioning can be obtained from ABB.

#### 8.1.3. Commissioning checklist

In order to ensure uncomplicated and speedy commissioning, it is important that drive and associated equipment are ready for commissioning. Reviewing and completing the items in the commissioning checklist before the commissioning personnel arrive on site will help to achieve this.

#### 8.1.4. Customer assistance

During the commissioning period, the customer is requested to provide qualified personnel for assistance, who are:

- Experienced with medium and low voltage equipment and with the local safety regulations,
- Familiar with the driven process
- Authorized to operate associated medium and low voltage equipment (eg, input circuit breaker, other low and medium voltage switchgear)
- Authorized to operate the driven process for functional tests

#### 8.1.5. Customer acceptance

When commissioning has been completed, the commissioning report is signed by the responsible commissioning personnel and by the customer as a sign of acceptance. A copy of the report and a copy of the actual parameter settings are handed out to the customer.

PRODUCT	DOCUMENT KIND	DOCUMENT ID.	REV.	LANG.	PAGE
ACS1000A	User manual	3BHS213401 E01	N	en	98/160

## 8.2. Commissioning checklists

The checklists are designed to help you prepare the drive and associated equipment for commissioning.

### 8.2.1. Mechanical installation checklist

- Drive installed according to the instructions in this user manual (3BHS213401 E01).
- Drive securely fastened to the floor (if applicable).
- Redundant fan unit installed (if applicable).
- Visual inspection:
  - No badly affixed or damaged components
  - No foreign objects left in the cabinet
  - No dirt, dust or moisture in the cabinet

### 8.2.2. Electrical installation checklist

- Types and cross sections of control cables suitable for the signal type and signal level.
- Types and cross sections of power cables selected according to the instructions in this user manual (3BHS213401 E01).
- Pulse encoder cable shields are connected to the shield earthing point and not connected directly to the pulse encoder interface (applies only to drives with pulse encoder interface).
- Cable entries prepared according to the instructions in the user manual (3BHS213401 E01).
- Control cable screens and conductors are connected as instructed in the user manual, labeled appropriately, and the customer side connections are completed.
- Equipotential bonding conductor of drive securely connected at both ends.
- Converter transformer and motor cables not connected at both ends (cables and drive must be insulation resistance tested (Megger test) before connection)

### 8.2.3. Main circuit breaker (MCB) checklist

- Type of MCB selected as per the MCB specification from ABB
- High-voltage power connections completed
- MCB ready to be tested with drive
- MCB protection relay settings tested
- Safety devices (eg, door locks) are tested and in operation.

### 8.2.4. Input transformer checklist

- Grounding is completed
- Transformer auxiliaries (eg, dehydrating breathers, cooling, protection devices) are ready.
- Safety devices (eg, door locks) are tested and in operation.

PRODUCT	DOCUMENT KIND	DOCUMENT ID.	REV.	LANG.	PAGE
ACS1000A	User manual	3BHS213401 E01	N	en	99/160

### 8.2.5. Motor checklist

- Motor is installed, aligned and alignment protocol available.
- Motor is not coupled to driven load.
- Grounding is completed
- Motor auxiliaries (eg, bearing lubrication) are ready
- Control and monitoring signals are connected.

### 8.2.6. Insulation tests checklist

- All power cables to converter transformer, between converter transformer and drive, and from drive to motor insulation resistance tested (Megger test), and measured values within the required limits.
- Test report of the Megger insulation resistance test available  
**IMPORTANT!** If the test is carried out by the commissioning engineer of the drive, an additional day per drive motor combination needs to be reserved. After the test, the feeder cables can be connected, except at the drive end. The test must comply with the specification.

### 8.2.7. Power supply checklist

- Medium voltage available for start-up of drive.
- Low voltage is available for start-up of drive.

### 8.2.8. Miscellaneous checklist

- Sufficient number and correct type of spare parts available
- Air conditioning of drive room ready for load run of drive
- Optional equipment ready

## 9. Operation

### 9.1. Safety



#### **! WARNING**

**Risk of electric shock** The IPXXB/IP20 rating of the low voltage compartment is not fulfilled by live parts with voltages > 50 V AC. If the compartment door is open during drive operation, contact with these accessible live parts can result in DEATH or serious injury!



→ Drive system must ONLY be operated by qualified and authorized personnel who are familiar with the operation of the drive system and the hazards involved

### 9.2. Overview

The chapter outlines the local operation of the drive.

Control of the drive via a PLC or higher-level control systems is not described in this chapter. If the drive is controlled from remote, see the appropriate manuals for information.

The panel messages and parameter settings used in this chapter are typical examples to illustrate the related instructions and display functions and can therefore differ from the actual messages and parameter settings in the drive.

### 9.3. Operating conditions

The operating conditions for the drive are according to IEC 60721-3-3.

- **Conditions:** 3K22 / 3B1 / 3S6 / 3M11

If the operating conditions are not within the specifications, contact ABB.

### 9.4. Sound pressure level

- **Single fan:** < 75 dB (A)
- **Redundant fan:** < 85 dB (A)

PRODUCT	DOCUMENT KIND	DOCUMENT ID.	REV.	LANG.	PAGE
ACS1000A	User manual	3BHS213401 E01	N	en	101/160

## 9.5. Local operator panel

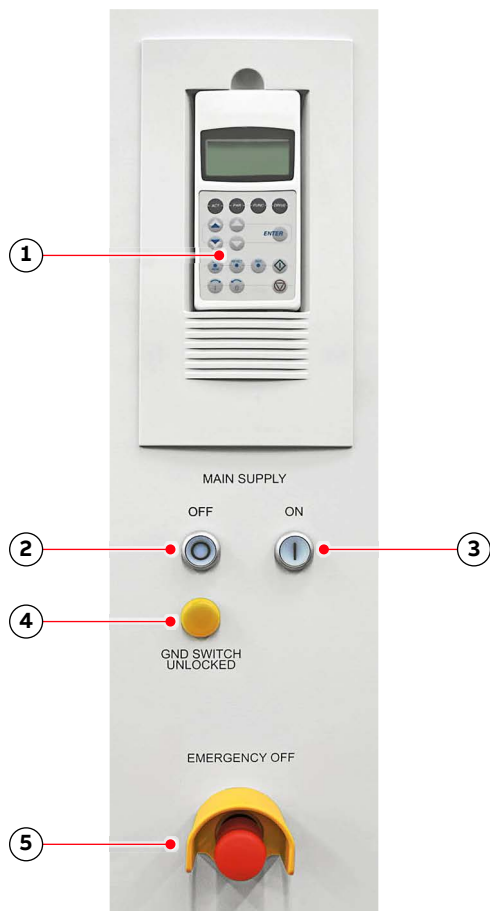

Under normal operating conditions, the local operator panel allows you to operate the drive without restrictions. For example, you can use the panel to perform the following actions:

- Connect and disconnect the main power supply
- Set the reference value
- Start and stop the drive
- Display actual values, status messages, alarms and fault messages
- View and setting parameters
- Reset alarm and fault messages
- Activate the emergency off circuit

For more information, see [10 CDP control panel on page 112](#).

Key	Explanation
(1) Control and data panel (CDP)	<ul style="list-style-type: none"> <li>- Starts and stops the motor</li> <li>- Displays status messages</li> <li>- Displays alarm and fault messages of the drive and monitored foreign equipment</li> <li>- Resets alarm and fault messages</li> </ul>
(2) Main Supply OFF illuminated push button	<ul style="list-style-type: none"> <li>- Opens the main circuit breaker</li> </ul>
(3) Main Supply ON illuminated push button	<ul style="list-style-type: none"> <li>- Charges the DC link and closes the main circuit breaker</li> </ul>
(4) Gnd Switch Unlocked push button	<ul style="list-style-type: none"> <li>- Lights up to indicate that the grounding switch of the drive can be turned to the grounded or ungrounded position</li> </ul>
(5) Emergency Off push button	<ul style="list-style-type: none"> <li>- Prevents starting when pressed at standstill of the drive</li> <li>- Main circuit breaker opens immediately and DC link discharges when pressed during operation of the drive</li> </ul>

**Figure 65 – Local operator panel**

## 9.6. Status messages

This section lists the messages of the main operating states the drive passes through, when it is put into operation, when it is stopped, or when a fault condition has occurred. The messages are sent to the higher-level control system and are displayed on the CDP control panel of the drive.

For information on other status messages, such as fault status messages in particular, see the status words in the “Appendix G - Signal and parameter table” of the drive.



### RdyForMCBOn

The status message signals that the drive is healthy and ready for the ON command. The ON command initiates the closing of the MCB and then the charging of the DC-link capacitors. Depending on the control place, the command can either be sent from the higher-level control system to the drive or be initiated by pressing the Main circuit online push button on the control compartment door.



### Charging

The status message **RdyForMCBOn** changes to **Charging** when the DC-link capacitors of the drive are being charged.



### Rdy to Strt

The status message **Rdy to Strt** tells the operator that the drive is energized and ready for operation. As soon as the start command is initiated, the motor is magnetized and the drive starts to modulate.



### Magnetizing

The status message **Rdy to Strt** changes to **Magnetizing** when the firing pulses of the inverter are released.



### Running

When the drive is in **Running** state, it is running and operating according to the set speed or torque reference value. When in remote control mode, the reference value is set by the higher-level control system. When in local control mode, the value is entered into the CDP control panel.



### Stopping

Indicates that the drive has received a stop command and that a ramp or coast stop has been initiated. The stopping mode depends on the parameter setting. The status message changes to **Rdy to Strt** when the zero speed threshold is reached.

When a start command is given while the drive is stopping, the drive resumes operation and the status message changes to **Running** again.



### Discharging

The status message **Rdy to Strt** changes to **Discharging** when the MCB has opened and the DC-link capacitors are discharging.



### Tripped

The status message indicates that a fault condition has occurred that requires a shutdown of the drive. The status message always alternates with the specific fault message. The type of shutdown depends on the fault class the fault condition is assigned to in the drive software.

## 9.6.1. Start sequence of the drive



### 1) NotReadyOn

ReadyOn conditions:

- Doors closed and locked
- Drive not grounded
- No emergency off
- No fault



### 2) ReadyForMCBOn



### 3) On command



### 4) Charging

- MCB closes
- DC link charges
- Fan switches on



### 5) Rdy To Strt



### 6) Start command

- Inverter starts to modulate



### 7) Magnetizing



### 8) Running



### 9) Operation

## 9.6.2. Stop sequence of the drive



1) **Operation**



2) **Running**



3) **Stop command**



4) **Stopping**

- Speed ramps down
- Inverter stops modulating



5) **Ready To Strt**



6) **Off command**



7) **Discharging**

- MCB opens
- DC link discharges
- Fan switches off after a delay



8) **RdyForMCBOn**

- Drive is grounded
- Doors are released for opening
- Auxiliary supply is switched off



9) **NotReadyOn**

## 9.6.3. Emergency off sequence of the drive



1) **Operation**



2) **Running**



3) **Emergency off command**

- MCB opens
- Inverter stops modulating
- Speed coasts down



4) **Not ready on**

## 9.7. Starting the drive



**DANGER**

**Hazardous voltages!** Unintentional contact with energized components can cause serious injuries or DEATH.

→ All covers must be screwed in place

### 9.7.1. Checks before starting the drive

Consult the following reference material for the initial local start of the drive after commissioning:

- “Appendix D - Wiring diagrams” to identify the circuit breakers to be switched on
- [10 CDP control panel on page 112](#) for information on functions and features of the CDP control panel

When the drive is put into service after it has been commissioned, or after it has been taken out of service for a longer period, check the drive according to the following list:

- Tools and foreign objects are inside the cabinet.
- All auxiliary power supplies from external sources are switched on.
- All internal circuit breakers of the drive are closed.
- All covers are mounted and the doors are closed, locked or bolted.
- Grounding switch is in the ungrounded position.
- MCB is in operating position.
- No run interlocks are active.

### 9.7.2. Starting the drive remotely

When the drive is operated from remote through a higher-level control system or an operator control desk, follow the instructions in the appropriate manuals.

### 9.7.3. Starting the drive locally

1. Enable the local control mode of the drive.



2. Check that no alarm or fault messages are displayed on the CDP control panel.
  - If a fault message is displayed on the CDP control panel, reset the fault.



- If a fault cannot be reset, it must be rectified by the responsible personnel.

When no alarms and faults are present and the drive is ready, the CDP control panel displays **RdyForMCBOn**:

1 L ->	0.0 rpm
Status	RdyforMCBOn
MotorSpeed	0.00 rpm
Power	0.0%

3. Press the **MAIN SUPPLY ON** push button on the control compartment door to close the MCB and charge the DC link.

The push button lights up and the status line of the CDP control panel changes to **Charging**.

1 L ->	0.0 rpm
Status	Charging
MotorSpeed	0.00 rpm
Power	0.0 %

After charging has been finished, the protection IGCTs are closed, the status line of the CDP control panel changes to **Rdy to Strt** and the motor can be started.

1 L ->	0.0 rpm	0
Status	Rdy to Strt	
MotorSpeed	0.0 rpm	
Power	0.0 %	

4. Enter the reference value.

1 L ->	[600.0 rpm]	0
Status	Rdy to Strt	
MotorSpeed	0.0 rpm	
Power	0.0 %	

## 5. Start the motor.

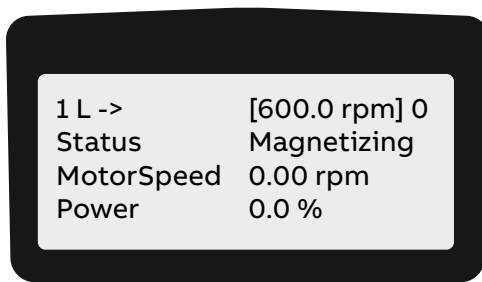

After the motor has been magnetized, the motor speed ramps up to the reference value. While the motor is accelerating, the run status indication on the display blinks. When the motor speed has reached the reference value, the run status indication lights up permanently. The display shows **Running** to indicate that the drive is operating.

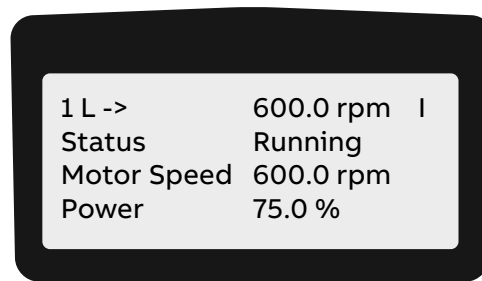

## 9.8. Stopping the drive

1. Press the STOP key on the CDP control panel.



The motor stops according to the preset stop function and the drive stops modulating. While the motor stops, the status line of the display shows **Stopping**. The run status message blinks during the stop sequence.

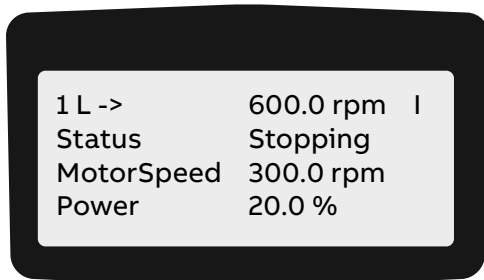

NOTE – As long as the stop sequence is in progress, the drive can always be restarted by pressing the START key on the CDP control panel.



When the drive has stopped modulating, the CDP control panel displays **Rdy to Strt**.

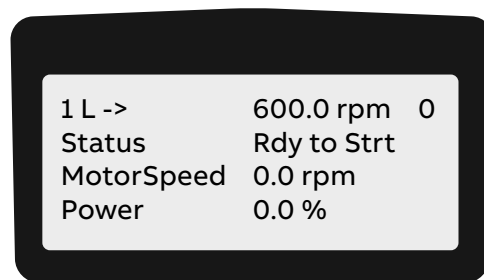

NOTE – As long as the MCB has not been opened, the motor can be started again.

## 9.9. Emergency-off

The drive is equipped with a hard-wired emergency off circuit. When an emergency situation occurs during operation, this safety feature ensures that the drive can be disconnected without delay from the main power supply. If the **EMERGENCY-OFF** push button has been pressed while the drive is at standstill, the main power supply cannot be connected to the drive, hence the drive cannot be started up.

The **EMERGENCY-OFF** push button of the drive is part of the operator control panel (Figure 65) and features a latching switch action.

**IMPORTANT!** Pressing the **EMERGENCY-OFF** push button does not disconnect the auxiliary power supply from the drive.

### 9.9.1. Initiating an emergency-off

To initiate an emergency off, press the **EMERGENCY-OFF** push button on the control compartment door, or an external **EMERGENCY-OFF** push button (if present) linked to the emergency-off circuit.

When an emergency-off is initiated during drive operation, the following takes place:

- MCB opens
- Drive coasts down
- Status line of the CDP control panel displays the message **Emerg Off**

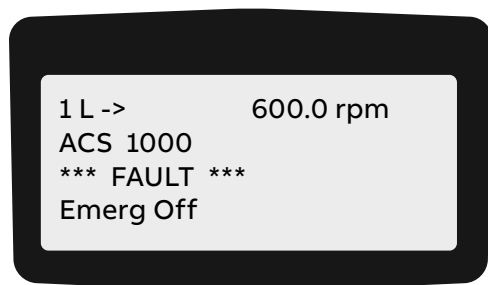

- The DC link of the drive discharges.

## 9.9.2. Starting the drive after an emergency-off

1. To start the drive after an emergency-off, unlatch the **EMERGENCY-OFF** push button. The **EMERGENCY-OFF** push button returns to its initial position when turned into the direction indicated by the arrows on the push button.
2. To reset the emergency-off safety relay of the drive, press the **RESET** button on the control keypad.



After resetting, the status message of the drive changes to **RdyForMCBOn**.

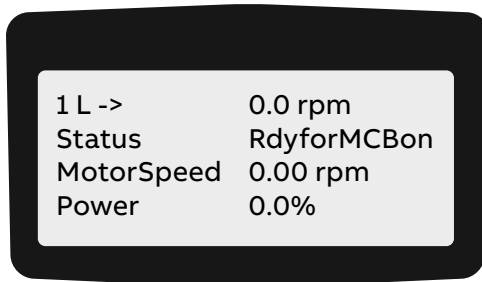

The main power supply can be connected to the drive and the drive can be started again.

# 10. CDP control panel

## 10.1. Overview

The panel messages and parameter settings used in this chapter are typical examples to illustrate the related instructions and display functions and can therefore differ from the actual messages and parameter settings in the drive.

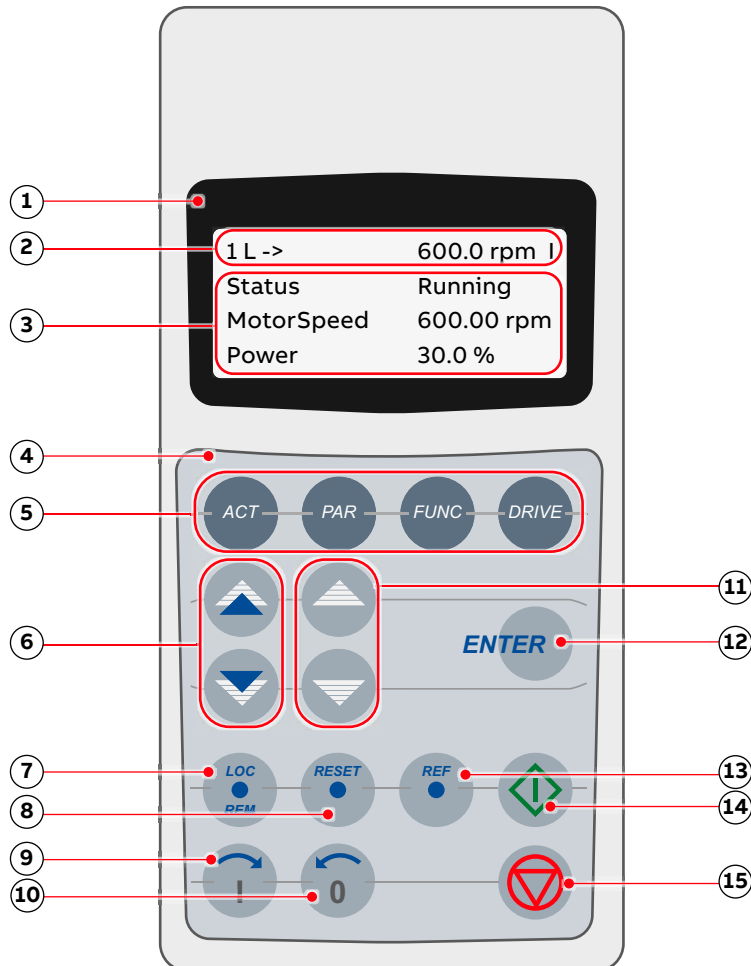

### Key

- |  |  |
|--|--|
| (1) Display  | (9) Forward key  |
| (2) Status line  | (10) Backward key  |
| (3) Actual signal names and values   | (11) Slow navigation key for selecting signals or fault messages |
| (4) Keypad   | (12) Enter key, terminates a procedure                           |
| (5) Mode selection keys  | (13) Reference key   |
| (6) Fast navigation key for selecting the actual signals display or the fault memory display | (14) Start key   |
| (7) Local / remote selection key   | (15) Stop key  |
| (8) Reset key  |  |

**Figure 66 – CDP control panel**

## 10.2. CDP control panel functions

The CDP control panel serves as the basic user interface for operating and monitoring the drive when the local operating mode has been selected.

The CDP control panel can be attached to or detached from the drive without having to switch off the auxiliary power supply first.

You can perform the following tasks with the CDP control panel:

- Enter start-up data
- Control the drive with a reference value, and start, stop and direction commands
- Display actual values (three values can be read simultaneously)
- Display and adjust parameters
- Display information on the most recent forty fault events
- Upload and download complete parameter sets from one drive to another

## 10.3. CDP control panel modes

The CDP control panel provides the following modes:

- Identification mode, see [10.3.1 Identification mode on page 113](#)
- Actual signals mode, see [10.3.2 Actual signals mode on page 114](#)
- Parameters mode, see [10.3.3 Parameters mode on page 121](#)
- Functions mode, see [10.3.4 Functions mode on page 127](#)

### 10.3.1. Identification mode

The identification mode informs the user about the CDP control panel version and the ID number of the drive. The information appears on the display when the:

- Power supply is switched on
- CDP control panel is connected to the drive and the auxiliary voltage has already been switched on.

When the CDP control panel is initialized as described before, the display changes as follows:

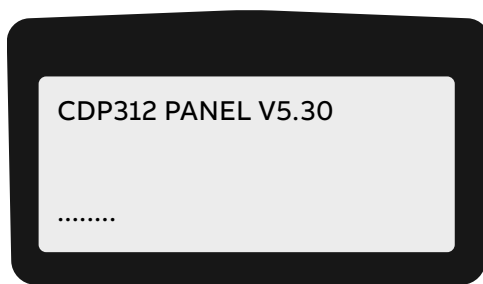

After 2 to 3 seconds, information on the drive (1, and 2) and the drive identification (3) is displayed.

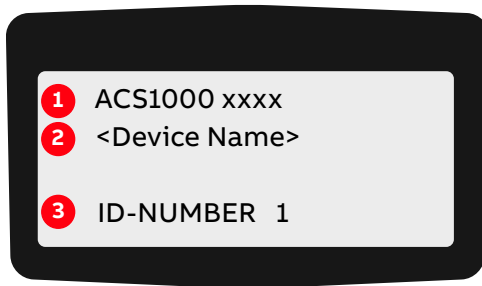

After another few seconds:

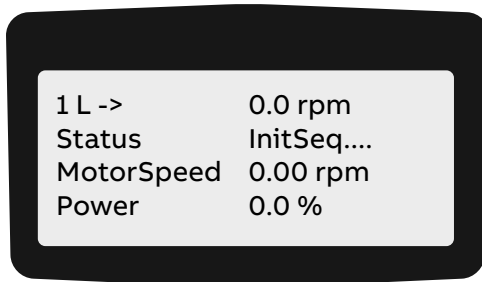

After another few seconds, the display changes to the actual signals mode.

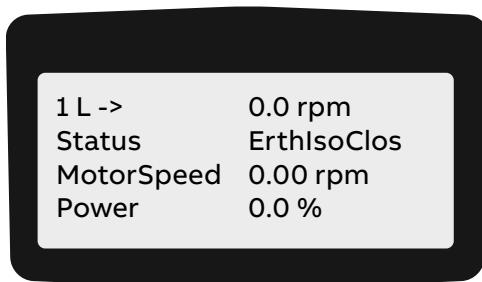

## 10.3.2. Actual signals mode

### 10.3.2.1. Overview

Two displays can be selected in the actual signals mode:

- Actual signals display
- Fault memory display

The actual signals display appears first when entering the actual signals mode. However, when the drive is in a fault condition, the fault memory display appears instead.

The actual signals display is used to monitor the drive without interfering with its operation. It continuously displays three selectable actual values.

The CDP control panel automatically returns to the actual signals display from other modes if no key is actuated within one minute (an exception from this is the fault memory display).

### 10.3.2.2. Actual values

The actual values are organized in groups.

Group	Description
Group 01	Measured or calculated motor values
Group 02	Measured or calculated drive values
Group 03	Speed and torque reference values
Group 04	I/O values
Group 05	Data values
Group 06	Information: software version, drive and motor nominal values
Group 07	Control words
Group 08	Status words
Group 09	Fault and alarm words

For the complete list of selectable actual signals, see “Appendix G - Signal and parameter table”.

### 10.3.2.3. Fault memory

The fault memory display provides information on the 64 most recent fault events that occurred in the drive. It displays the name of the fault and the time it occurred. For instructions on how to display and reset the fault memory, see [10.3.2.5 Displaying and resetting the fault history on page 119](#).

When the drive generates a fault or alarm, the corresponding message displays immediately.

Changing from the fault memory mode to other modes is possible without resetting the fault first. When no key is actuated, the fault or warning text is displayed as long as the fault is active.

## Control panel overview

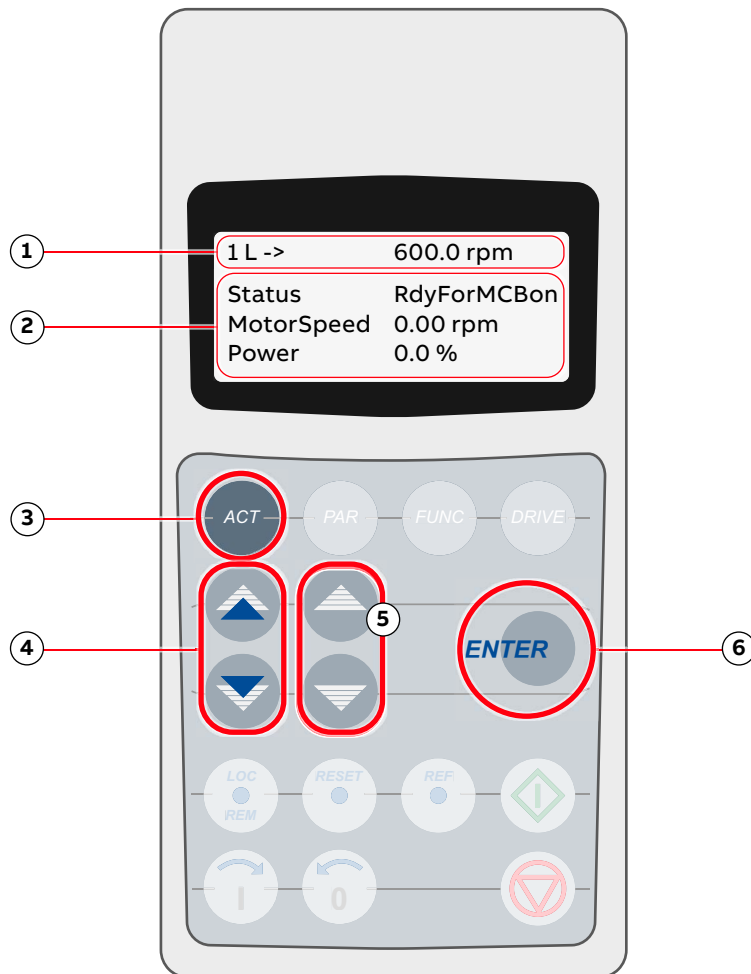

### Key

- (1) Status line
- (2) Actual signal names and values
- (3) Selection key for actual signals mode
- (4) Fast navigation key for selecting the actual signals display or the fault memory display
- (5) Slow navigation key for selecting signals or fault messages
- (6) Enter key for confirming the selection

**Figure 67 – Control panel - Actual signals mode**

### 10.3.2.4. Opening the actual signals display

- To open the actual signals display, press the ACT key.

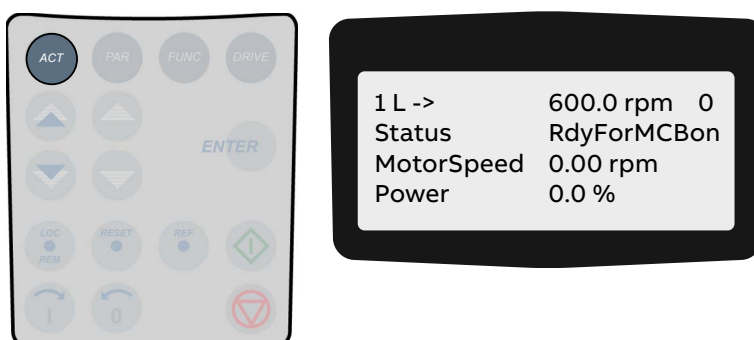

## Toggle between actual signals display and fault history

- To toggle between actual signals display and fault history display, press a fast navigation key.



## Displaying three actual signals

1. To display the full name of three actual signals, press and hold the **ACT** key.

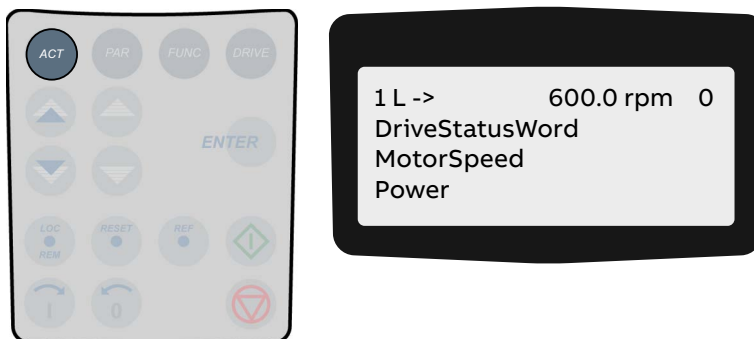

2. To return to the actual signals display, release the **ACT** key.

## Selecting actual signals

1. To select the actual signals display, press the **ACT** key.

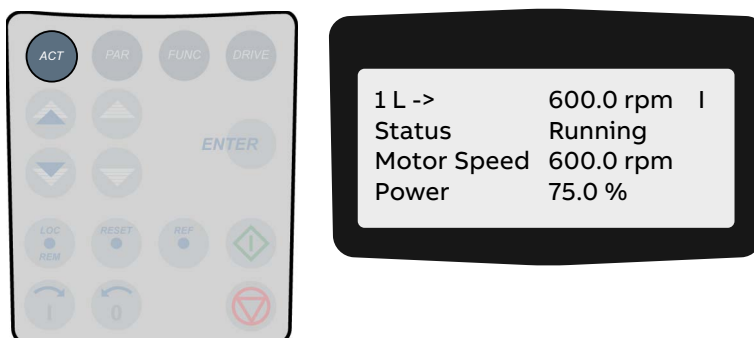

To select a line where the actual signal is to be displayed, press the corresponding slow navigation key.

A **blinking** cursor indicates the selected line.

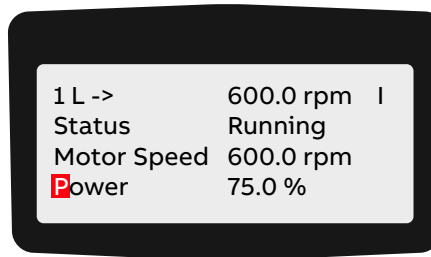

2. To enter the actual signal selection function, press the **ENTER** key.

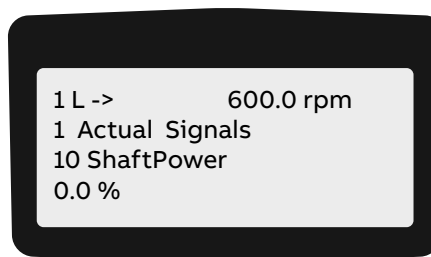

3. To select a parameter group, press a fast navigation key.

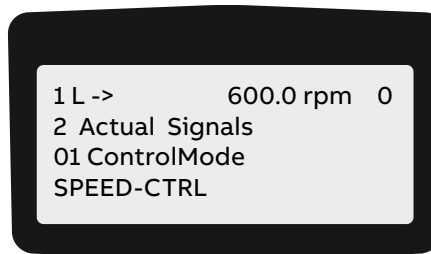

4. To select an actual signal, press a slow navigation key.

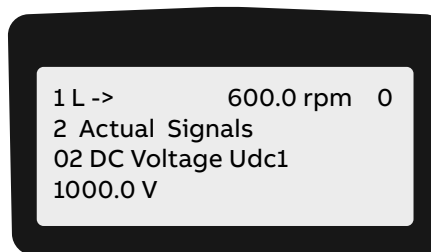

5. To confirm the selection and to return to the actual signals mode, press the **ENTER** key.

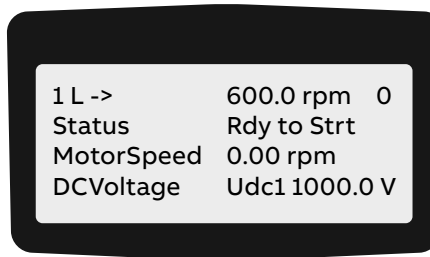

6. To cancel the selection and keep the original selection, press any of the mode selection keys.  
The selected CDP control panel mode is entered.

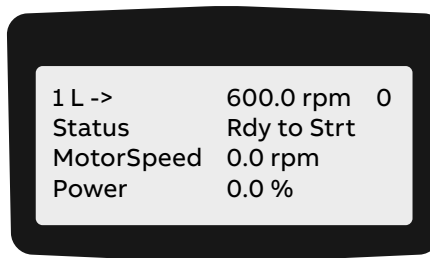

### 10.3.2.5. Displaying and resetting the fault history

1. To enter the actual signals mode, press the **ACT** key.

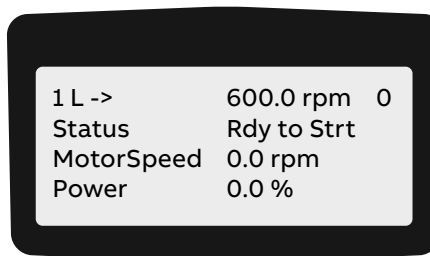

2. To change to the fault memory display, press a fast navigation key.

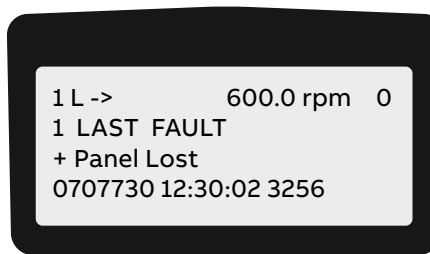

- To display a specific fault, press the slow navigation keys.  
The UP key selects the previous, the down key the next fault.



- To clear the fault memory, press the **RESET** key.



- To return to the actual signals display, press a fast navigation key.

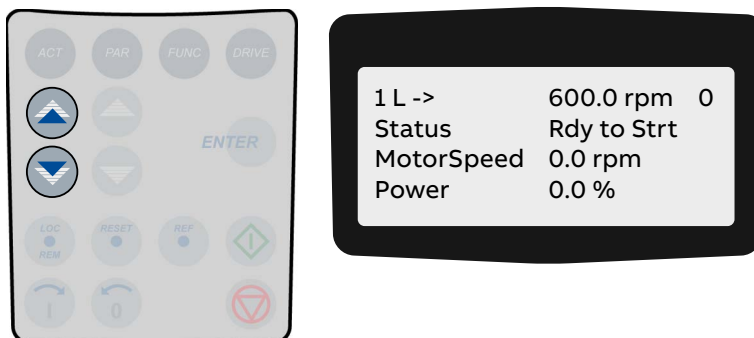

### Displaying and resetting an active fault

- To display an active fault, press the **ACT** key.



2. To reset the fault, press the **RESET** key.

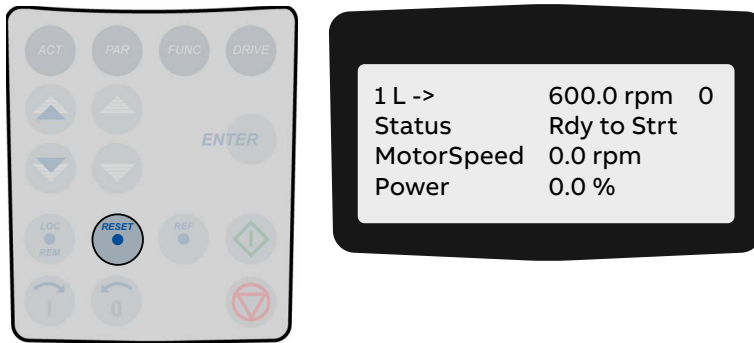

### 10.3.3. Parameters mode

#### **NOTICE**

**Risk of component damage.** Running the drive system with incorrect data can result in improper operation, reduction of control accuracy and damage to equipment.

- Parameters must only be set by qualified personnel.
- DO NOT change a parameter if the effects of the change are unclear.

#### 10.3.3.1. Overview

If the parameter lock is disabled or unlocked (see [10.3.3.3 Enabling / unlocking a parameter lock on page 126](#)), the parameters mode allows entering the parameter settings for the required drive configuration depending on the application.

The parameters are organized in functional groups, so called parameter groups.

**Table 16 – Parameter groups**

Group	Description
Group 07	Control words
Group 08	Status words
Group 09	Fault and alarm words
Group 11	Start, stop, direction, MCB and control
Group 12	Reference selection
Group 13	Basic analog inputs
Group 14	Basic digital outputs
Group 15	Basic analog outputs
Group 16	System control inputs
Group 17	Utilities
Group 18	Process speed
Group 19	Data storage
Group 20	Limits
Group 21	Start, stop and process stop
Group 22	Ramp functions
Group 23	Speed reference

For details about the parameters, their settings and functions, see “Appendix G - Signal and parameter table”.

When entering the parameter mode for the first time after the auxiliary voltage of the drive has been switched on, the CDP control panel displays the first parameter of parameter *group 99*. The next time the parameters mode is entered, the previously selected parameter displays.

Some parameter values cannot be changed while the drive is running. If tried, the following warning displays.

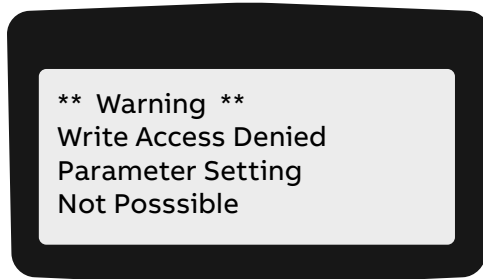

## Control panel overview

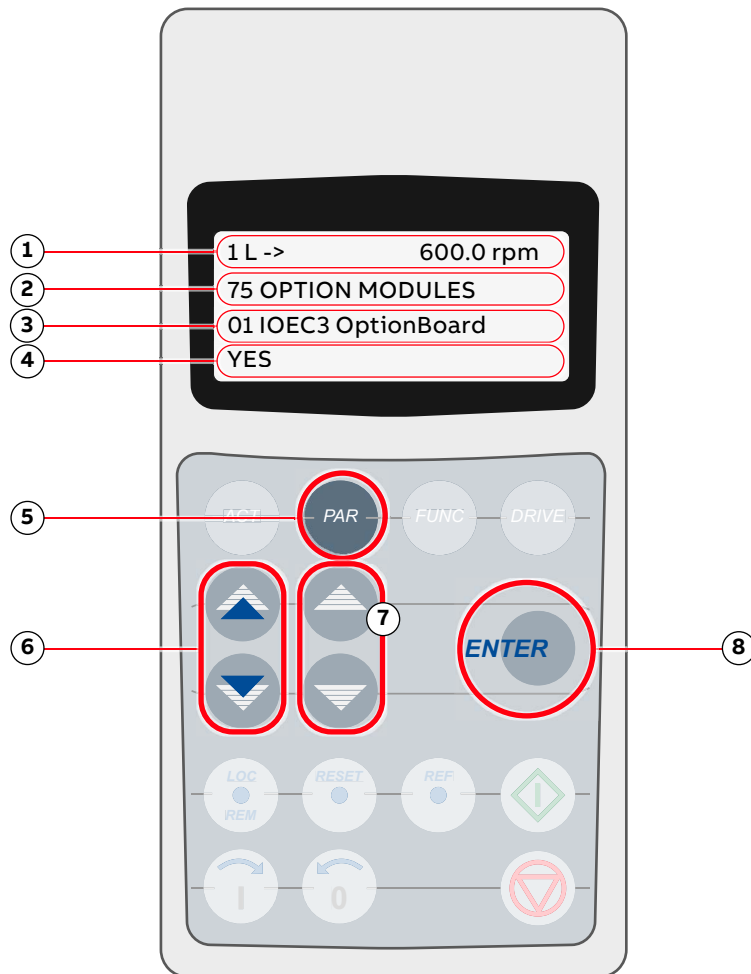

### Key

- (1) Status line
- (2) Group number and name
- (3) Parameter number and name
- (4) Parameter value
- (5) Selection key for parameters mode

### Key

- (6) Fast navigation key for selecting a parameter group (and a parameter value)
- (7) Slow navigation key for selecting a parameter (and a parameter value)
- (8) Enter key for confirming the selection

**Figure 68 – Control panel - Parameters mode**

### 10.3.3.2. Selecting and changing parameters

1. To enter the parameters mode, press the PAR key.

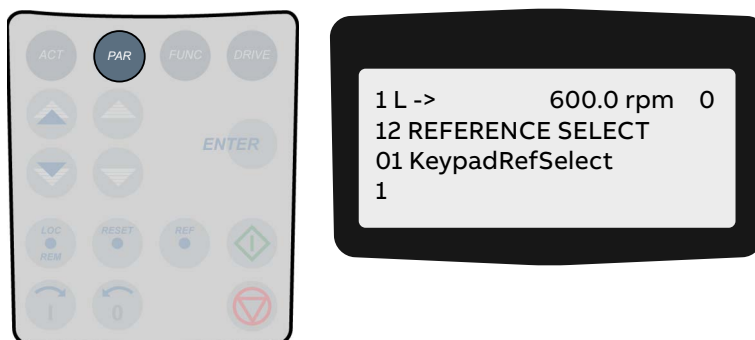

2. To select a different group, press the corresponding fast navigation key.

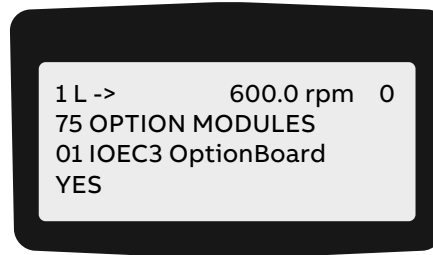

3. To select a parameter, press the corresponding slow navigation key.

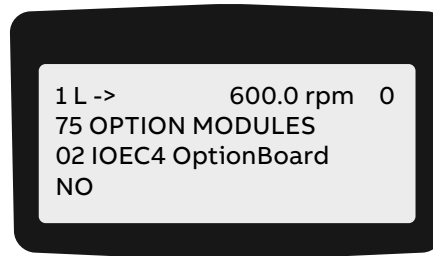

4. To enter the parameter setting function, press the **ENTER** key.

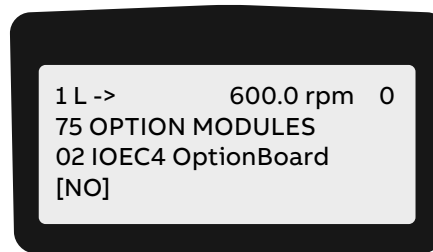

5. To change the parameter value, press the:

- Slow navigation key for numbers and text
- Corresponding fast navigation key for numbers only

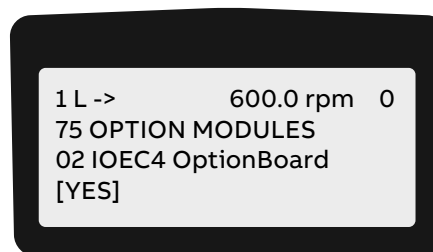

6. To confirm the selection and to return to the actual signals display, press the **ENTER** key.

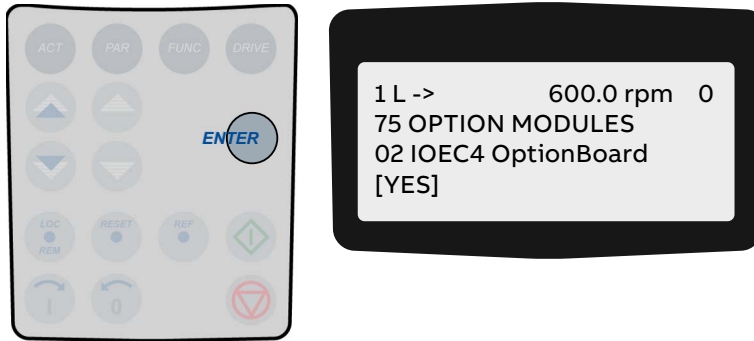

7. To cancel the setting and keep the original selection, press any of the mode selection keys.  
The selected keypad mode is entered.



### 10.3.3.3. Enabling / unlocking a parameter lock

Unwanted parameter entry can be prevented by activating the parameter lock function.

The corresponding parameters are *16.02 PARAMETER LOCK* and *16.03 PASSCODE* and belong to parameter group *16 SYSTEM CTRL INPUTS*.

#### Enabling the parameter lock

1. Select parameter *16.02*.
2. Set parameter *16.02* to **1 (LOCKED)**.
3. Confirm the setting and exit the parameters mode.

#### Unlocking the parameter lock

1. Select parameter *16.03*.
2. Set the correct pass code.
3. Confirm the setting and exit the parameters mode.

For more information, see “Appendix G - Signal and parameter table”.

### 10.3.3.4. User lock

#### **NOTICE**

**Risk of component damage.** ABB is not be liable for damages or losses caused by the failure to activate the user lock with a new pass code.

#### Setting the master pass code

ABB recommends that you set a master pass code to lock the control panel to protect the parameter values.

1. To activate the user lock for the first time, enter the default pass code, ie, **358**, in *16.03 Passcode*. You can now edit parameters *16.06...16.07*.
2. Enter the old pass code in *16.06 OldUserPasscode*.
3. Enter the new pass code in *16.07 NewUserPasscode*.
4. In *16.02 Parameter Lock*, enable the user lock functionality.  
NOTE – To reopen the lock, ie, to edit parameters *16.06* and *16.07*, enter the new pass code in *16.03 Passcode*.

PRODUCT	DOCUMENT KIND	DOCUMENT ID.	REV.	LANG.	PAGE
ACS1000A	User manual	3BHS213401 E01	N	en	126/160

### 10.3.4. Functions mode

The functions mode is used to set the display contrast.

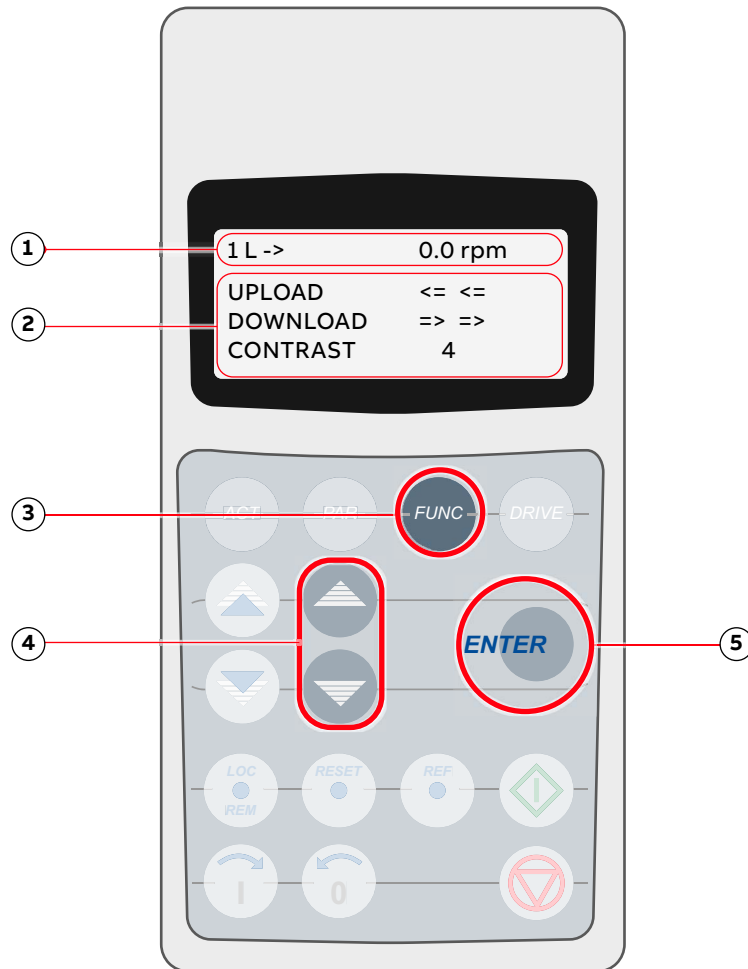

#### Key

- (1) Status line
- (2) Selectable functions
- (3) Selection key for functions mode
- (4) Slow navigation key for selecting a line (and adjusting the contrast)
- (5) Enter key for confirming the selection

**Figure 69 – Control panel - Functions mode**

#### 10.3.4.1. Adjusting the display contrast

1. To enter the functions mode, press the **FUNC** key:



2. To select the contrast adjustment function, press the slow navigation keys until the **blinking** cursor reaches the **CONTRAST** line.

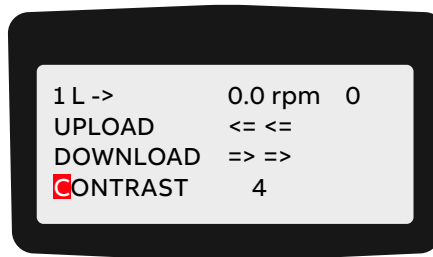

3. Press the **ENTER** key.

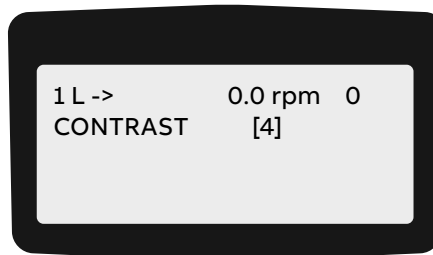

4. To change the contrast value, press a slow navigation key.

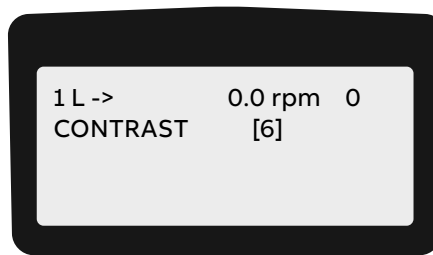

5. To confirm the selection and to return to the actual signals display, press the **ENTER** key.

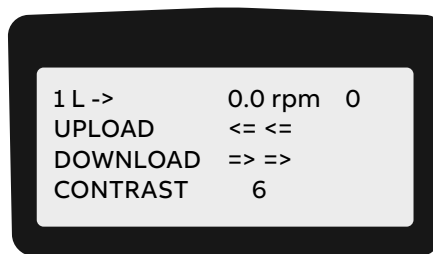

6. To cancel the setting and keep the original setting, press any of the mode selection keys. The selected keypad mode is entered.



## 10.4. Local and remote control

The local-remote feature of the CDP control panel allows selecting the control location of the drive. Possible are:

- Local control
- Remote control

In this context, remote control is not necessarily equivalent to higher-level control. For more information, see [10.4.2 Remote control on page 130](#).

### 10.4.1. Local control

In local control mode, full operational control of the drive is enabled from the local operator panel. Commands from remote have no effect.

#### Entering local control mode

- To enter the local control mode, press the **LOC-REM** key.

Local control is indicated by the letter **L**.

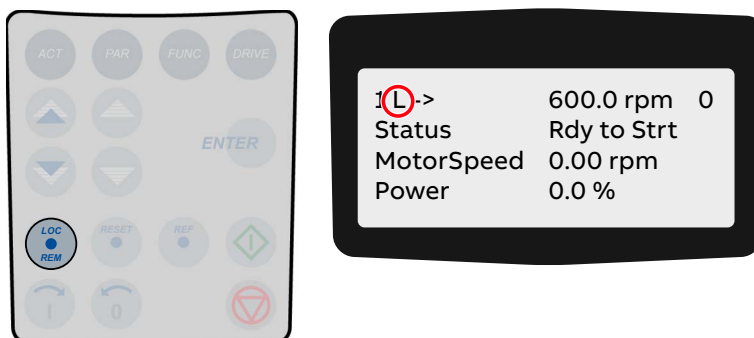

## 10.4.2. Remote control

In remote control mode, operational commands or reference values come from a higher-level control system via fieldbus or remote I/O.

However, with the following parameter settings it is possible to start and stop the drive, to set the motor's direction of rotation, and to enter reference values from the CDP control panel.

- 11.01 EXT1 START/STOP/DIR = 10 (KEYPAD) or  
12.03 EXT REF1 SELECT = 1 (KEYPAD) and  
12.02 EXT1/EXT2 SELECT = 1 (EXT1)
- 11.02 EXT2 START/STOP/DIR 10 (KEYPAD) or  
12.06 EXT REF2 SELECT = 1 (KEYPAD) and  
12.02 EXT1/EXT2 SELECT = 2 (EXT2)

### Entering remote control mode

- To enter remote control, press the **LOC-REM** key.
  - Full remote control from a higher-level control system is indicated by a blank space.

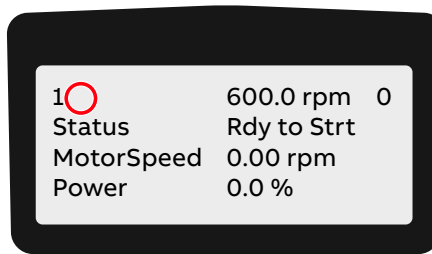
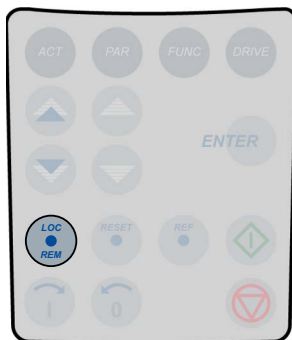

- Partial remote control (some commands enabled locally) is indicated by the letter **R**.

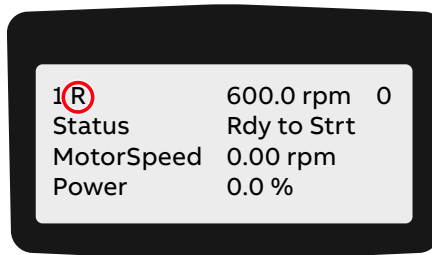

## 10.5. Operational commands

For instructions on how to start and stop the drive system from the CDP control panel, see [9.7 Starting the drive on page 106](#) and [9.8 Stopping the drive on page 109](#).

### 10.5.1. Setting the direction of rotation

Setting the direction of rotation from the CDP control panel is possible in:

- Local control mode **L**
- Remote control mode **R**

The arrow on the display indicates the direction of rotation:

- When the motor is running, the arrow indicates the actual direction.
- When the motor is not running, the arrow indicates the preselected direction.

#### Procedure

- To set the direction of rotation, press the forward or backward key.

If you change the direction while the motor is running, the motor automatically ramps down to zero speed and re-accelerates in the opposite direction to the preset speed. The arrow changes at zero speed.

- Forward key

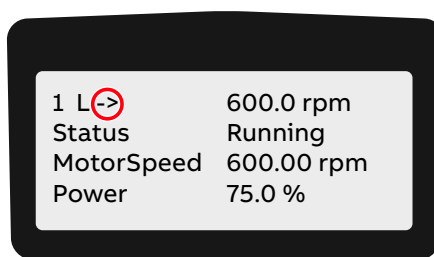

- Backward key

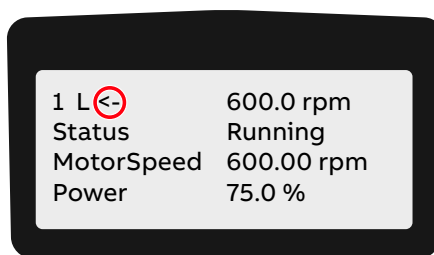

## 10.5.2. Entering a reference value

Entering a reference value from the CDP control panel is possible in local control mode **L** and remote control mode **R**.

### Procedure

1. Press a mode selection key.



```
1 L ->      600.0 rpm |
Status      Running
MotorSpeed  600.00 rpm
Power       75.0 %
```

2. To enter the reference value input mode, press the **REF** key.



```
1 L ->      [600.0 rpm] |
Status      Running
MotorSpeed  600.00 rpm
Power       75.0 %
```

3. To enter / change the reference value, press the corresponding fast or slow navigation key.



```
1 L ->      [550.0 rpm] |
Status      Running
MotorSpeed  600.00 rpm
Power       75.0 %
```

4. To exit the reference value input mode, press any of the mode selection keys.



```
1 L ->      550.0 rpm |
Status      Running
MotorSpeed  550.00 rpm
Power       75.0 %
```

# 11. Preventive and corrective maintenance

## 11.1. General information

During the warranty period of the drive, all maintenance must be performed exclusively by ABB service personnel. After the warranty period, maintenance must only be performed by certified personnel.

### 11.1.1. Required qualification

To maintain safe and reliable operation of the drive, ABB recommends taking out a service contract with the ABB service organization.

### 11.1.2. Maintenance schedule

Perform all maintenance tasks according to the maintenance schedule and the applicable service instructions, on time and at the intervals stated in the “ACS1000A preventive maintenance schedule”, 3BHS855276 E01.

### 11.1.3. Logbook

ABB recommends that you keep track of all troubleshooting and maintenance work in a logbook including:

- Date and time
- Detailed description

### 11.1.4. Spare parts

To ensure safe and reliable operation, use only spare parts recommended and approved by ABB. For information on types and identification codes, see “Appendix E - Parts list”.

PRODUCT	DOCUMENT KIND	DOCUMENT ID.	REV.	LANG.	PAGE
ACS1000A	User manual	3BHS213401 E01	N	en	133/160

## 11.2. Identifying electrical equipment

This section describes how to identify electrical devices, cables, and wires.

### 11.2.1. Device identification

To facilitate the identification in wiring diagrams and parts lists, all devices are labeled in accordance with IEC 81346-1.

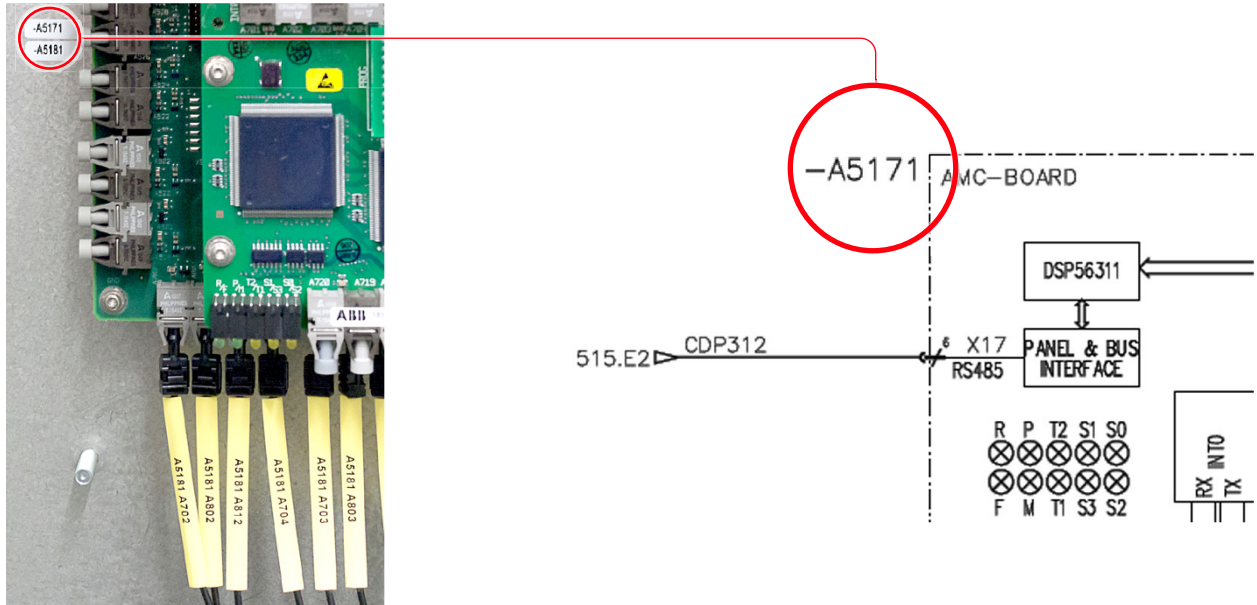

Figure 70 – Device identification

### 11.2.2. Cables and wires

Cables and wires in the drive are equipped with marker sleeves which carry the same identification number as in the wiring diagrams.

### 11.2.3. Understanding wiring diagrams

For information on item designation and cross-reference conventions, see “Appendix D - Wiring diagrams”.

## 11.3. Alarm / fault indications

### 11.3.1. Messages

When a failure occurs in the drive or in the equipment monitored by the drive (eg, main circuit breaker, transformer, cooling system), the CDP control panel displays a corresponding alarm or fault message.

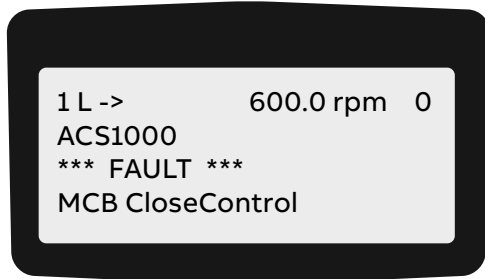

The message can be saved and viewed in the fault history of the drive when a PC with the DriveWindow or DriveDebug is connected to the drive. The fault logger can also be called up on the CDP control panel.

### 11.3.2. Error message levels

Two error message levels are used in the drive:

- **Alarm:** Does not shut down the drive. If the condition causing the alarm is not corrected, a persisting alarm can lead to a fault. An alarm cannot be reset manually. The alarm message is deleted from the display as soon as the alarm condition has been corrected.  
NOTE – An exception is when an alarm of the cooling system (eg, *FanDiffPres*, *AirFiltSupv*) is not reset automatically. To reset the alarm, set parameter *41.04 FanAlarmReset* to **RESET**.
- **Fault:** Shuts down the drive. The type of shutdown depends on the origin of the fault. Depending on the type of fault, the drive opens the main circuit breaker (MCB) or keeps it closed. A fault condition must be corrected and the fault be manually reset before the drive can be started again.

#### 11.3.2.1. Alarm / fault messages

If an alarm or a fault occurs, a specific message is saved in the fault buffer of the drive. Information on the 64 most recent fault and alarm events are saved.

### 11.3.3. Fault handling

The faults are entered into the fault logger as they occur and are numbered:

- The last fault entered always has number 1 assigned to it.
- The first fault always has the highest number in the fault buffer.

Date and time stamps facilitate fault tracing, especially when a fault leads to several subsequent faults.

**Example:**

1) <b>-Fault RESET FAULT</b>	2011-04-26 14:57:56.5370
2) <b>+Fault Undervoltage</b>	2011-04-26 14:47:41.1110
3) <b>+Warn Undervoltage</b>	2011-04-26 14:47:41.1000
4) <b>+Fault MCB Disturb</b>	2011-04-26 14:47:38.0230

In the above example:

- 4) **+Fault MCB Disturb** is the reason for the failure of the drive, as it occurred first.
- 3) **+Warn Undervoltage** occurred approximately 3 seconds after the first fault.
- 2) **+Fault Undervoltage** immediately followed the warning.
- 1) **-Fault RESET FAULT** informs that the fault has been reset.

For more information on alarms and faults, see “Appendix G - Signal and parameter table”.

### 11.3.4. Standard troubleshooting procedure

If a fault shuts down the drive, proceed as follows:

- 1) **DO NOT switch off the auxiliary supply voltage or try to reset a fault message before all information at the time of the occurrence of the fault condition has been saved.**
- 2) **Select the fault history display on the CDP control panel, but DO NOT clear the buffer!**  
For more information, see [9 Operation on page 101](#).
- 3) **Identify the fault and make a logbook entry.**
- 4) **Save the content of the data logger when a PC is available that has the DriveWindow or DriveDebug tool installed.**  
The data logger provides information (eg, waveforms of voltage, current, torque) for efficient troubleshooting.
- 5) **Contact ABB service if a fault cannot be rectified.**  
When calling ABB service, it is recommended to have the following data available at the time when the fault occurred:
  - Operating, ambient and load conditions
  - Unusual events
- 6) **After the fault has been rectified, start the drive as described in [9 Operation on page 101](#).**

## 11.4. Removing the CDP control panel

**IMPORTANT!** If the CDP control panel is removed during operation, the drive can only be stopped by pressing the **EMERGENCY OFF** button.

1. If the panel is removed while the drive is in operation, check the setting of parameter *31.06 PANEL LOSS SUPERVISION* first.

If the parameter is set to **NOT USED**, the panel can be removed without interrupting drive operation. For information on setting parameters, see “Appendix G - Signal and parameter table”.

2. Proceed as illustrated.

The green LED (4) signals that the control voltage has been switched on.



## 11.5. LEDs and switches on circuit boards

The following section provides an overview on the meaning of LEDs and switches of the main circuit boards and I/O devices. The LEDs presented in the following section can be checked easily with the auxiliary voltage switched on and without having to remove covers first. The LEDs provide information on the status of the devices and can be used for diagnostic purposes.

### 11.5.1. AMC circuit board

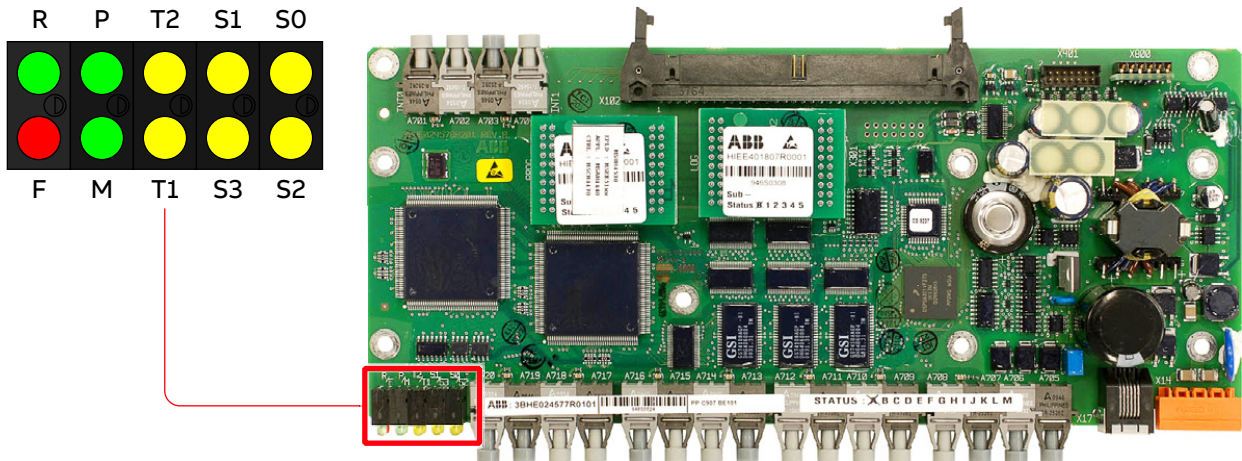

LED	Color	Description	Status when software has loaded		Status when software has not loaded	
			Booting	ON	Booting	ON
F	Red	Fault	ON	OFF	ON	ON
R	Green	Run	OFF	OFF	OFF	OFF
M	Green		ON	OFF	ON	ON
P	Green	Supply OK	ON	ON	ON	ON
T1	Yellow	Receiving data on DDCS channel 0	Flashing	ON / OFF	Flashing	ON / OFF
T2	Yellow	Receiving data on DDCS channel 3	Flashing	ON / OFF	Flashing	ON / OFF
S3	Yellow		OFF	OFF	OFF	OFF
S1	Yellow		Flashing	OFF	Flashing	OFF
S2	Yellow		Flashing	OFF	Flashing	OFF
S0	Yellow		Flashing	OFF	Flashing	OFF

Figure 71 – AMC circuit board

## 11.5.2. IOEC I/O modules

### 11.5.2.1. LEDs

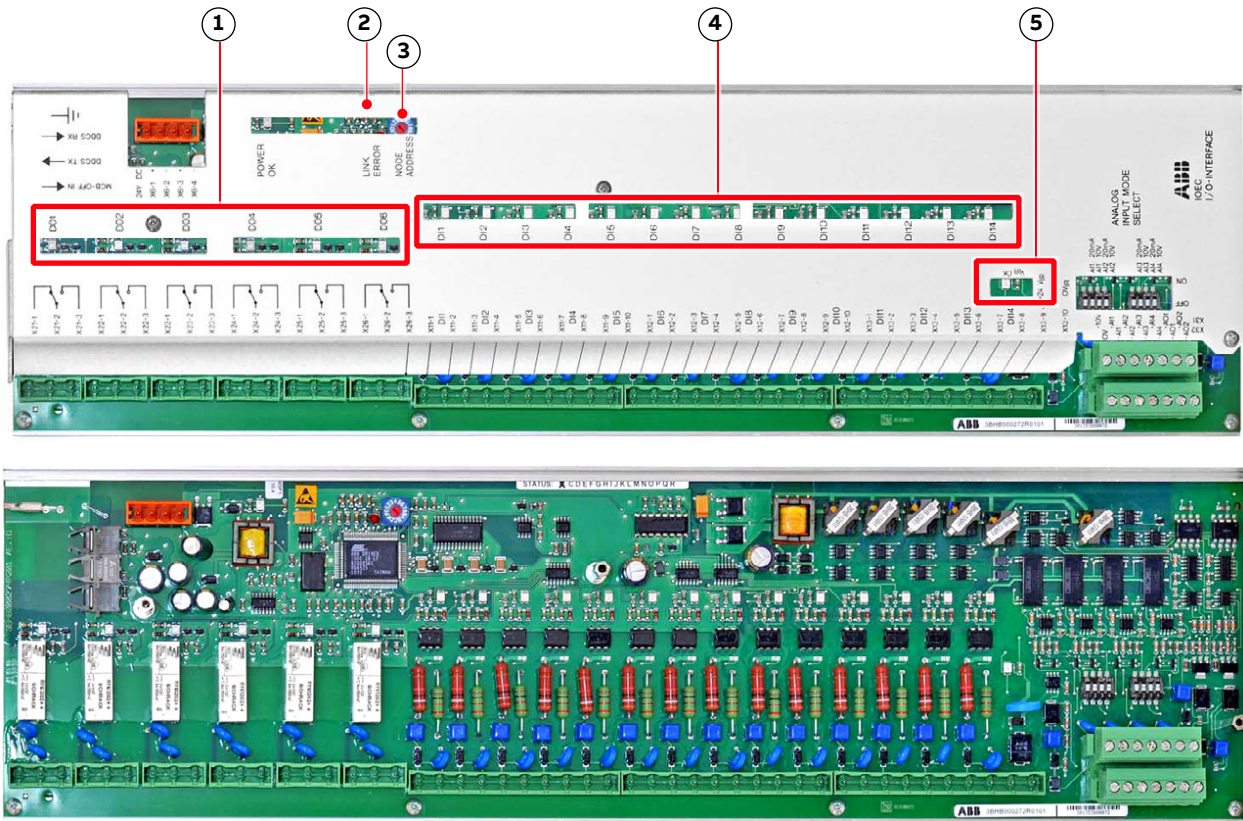

Key	Explanation
(1) Status LED of digital outputs	On when output is energized
(2) Link error light	Only on when there is a problem with the optical fibers.
(3) Rotary switch	Sets the address
(4) Status LEDs of digital inputs	On when input is energized
(5) Status LED of the 24 V internal voltage supply	On when energized

Figure 72 – IOEC module

### 11.5.2.2. Cluster address

Each IOEC module has a unique cluster address that identifies the module in the software and links it to a parameter.

The address is set with the rotary switch on the module (3, Figure 72). The factory-set value must not be changed.

For information on IOEC switch settings, see “Appendix C - Mechanical drawings”.

## 11.6. Corrective maintenance

Overview on maintenance tasks:

- 11.6.6 Visual checks on the drive on page 145
- 11.6.7 Cleaning the drive on page 145
- 11.6.8 Checking wire and cable connections on page 146
- 11.6.9 Cleaning and replacing filter mats on page 146
- 11.6.10 Inspecting and replacing batteries on page 149
- 11.6.11 Replacing the non-redundant fan on page 151
- 11.6.12 Replacing a redundant fan on page 154

### 11.6.1. Safety



#### **DANGER**

**Hazardous voltages!** Before starting to work on the drive, make sure that:

- Main and auxiliary power supply to the drive is switched off, locked out, and tagged out
- Drive is de-energized
- Safety ground connections are in place
- Personal protective equipment is provided and used when required
- Everyone involved is informed

Before energizing the drive again, make sure that:

- All foreign objects are removed from the drive
- All internal and external covers are securely fastened and all doors are closed, locked and / or bolted

#### **NOTICE**

**Risk of component damage.** Foreign matter and particularly metallic dust can cause failure and damage when the drive is energized.

Ensure that foreign matter cannot enter the cabinet:

- Close the doors and cover openings completely when work is discontinued.
- Retrieve any foreign matter which accidentally dropped into the cabinet.



#### **WARNING**

**10 min**

**Risk of electric shock!** Contact with a charged capacitor can cause serious injury or DEATH!

- After the drive has been de-energized, wait a MINIMUM of 10 minutes for the capacitors to fully discharge
- Verify that a capacitor is discharged before you touch it



The IPXXB/IP20 rating of the low voltage compartment is not fulfilled by live parts with voltages > 50 V AC. If the compartment door is open during drive operation, contact with these accessible live parts can result in DEATH or serious injury!

- Work must ONLY be performed by qualified personnel with electrotechnical expertise

PRODUCT	DOCUMENT KIND	DOCUMENT ID.	REV.	LANG.	PAGE
ACS1000A	User manual	3BHS213401 E01	N	en	140/160

### 11.6.2. De-energizing the drive locally

The following section describes how to de-energize the drive using the local operator panel of the drive. If the drive is controlled from remote, follow the established shutdown procedures.

1. Enable the local control mode of the CDP control panel.  
For more information, see [10 CDP control panel on page 112](#)
2. Press the stop key.



When the motor has reached zero speed, the display shows **Rdy to Strt**.

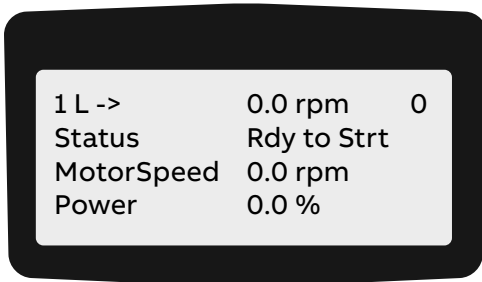

3. Press the **MAIN SUPPLY OFF** push button to disconnect the drive from the main power supply  
The following takes place:
  - MCB opens
  - DC link discharges for approximately five minutes
 While the DC link discharges, the display shows the following.

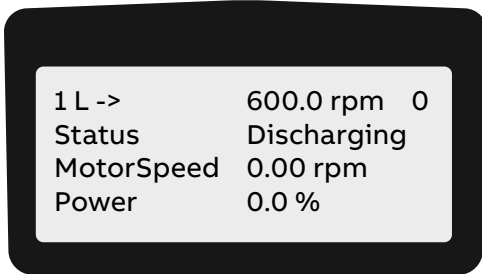

**Alternating display message:**

- Discharging
- CoolOFFDelay
- RdyForMCBOn

When the DC link has discharged completely, the status line displays **RdyforMCBOn** and the **MAIN SUPPLY OFF** push button lights up.

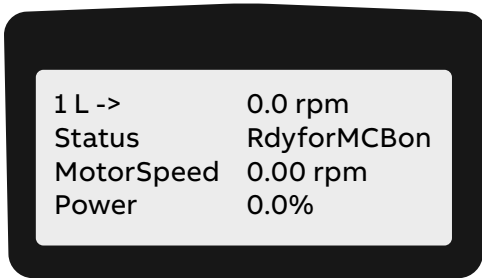

4. Rack-out, lock-out, ground and tag-out the main power feeder.

5. If the grounding switch is equipped with the optional lock (1) that secures the switch in the ungrounded position, unlock the grounding switch.



6. Wait until the yellow lamp **GROUNDING SWITCH UNLOCKED** lights up. The lamp lights up when cooling stops after a delay time.
7. If the yellow lamp is on, continue with [11.6.3 Grounding on page 142](#).
8. If the yellow lamp is not on, continue with [11.6.4 Grounding switch is not released on page 143](#).

### 11.6.3. Grounding

1. If the yellow lamp is on, turn the grounding switch to the grounded position. When the grounding switch is in the grounded position, the status line of the CDP control panel displays **ErthIsoClos**. (Earth isolator closed = grounding switch is in grounded position).

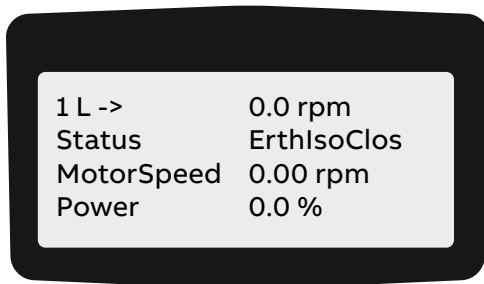

2. To de-energize the drive completely, switch off and lockout all auxiliary voltages from external sources.  
NOTE – To open the doors of medium voltage compartments and additional cabinets of the drive that are equipped with an electromechanical lock, the auxiliary voltage must be switched on.
3. If necessary, connect a grounding set.

### 11.6.4. Grounding switch is not released



#### **CAUTION**

**Hazardous voltage!** Forcing the grounding switch can damage the switch and short-circuit the DC-link capacitors!

- DO NOT force the grounding switch when the **GROUNDING SWITCH UNLOCKED** lamp is off.
- If you cannot operate the grounding switch, see [11.6.5 Checking the release conditions for the grounding switch on page 144](#).

NOTE – To identify the components referred to in the checklist, see the wiring diagrams and Figure 73.

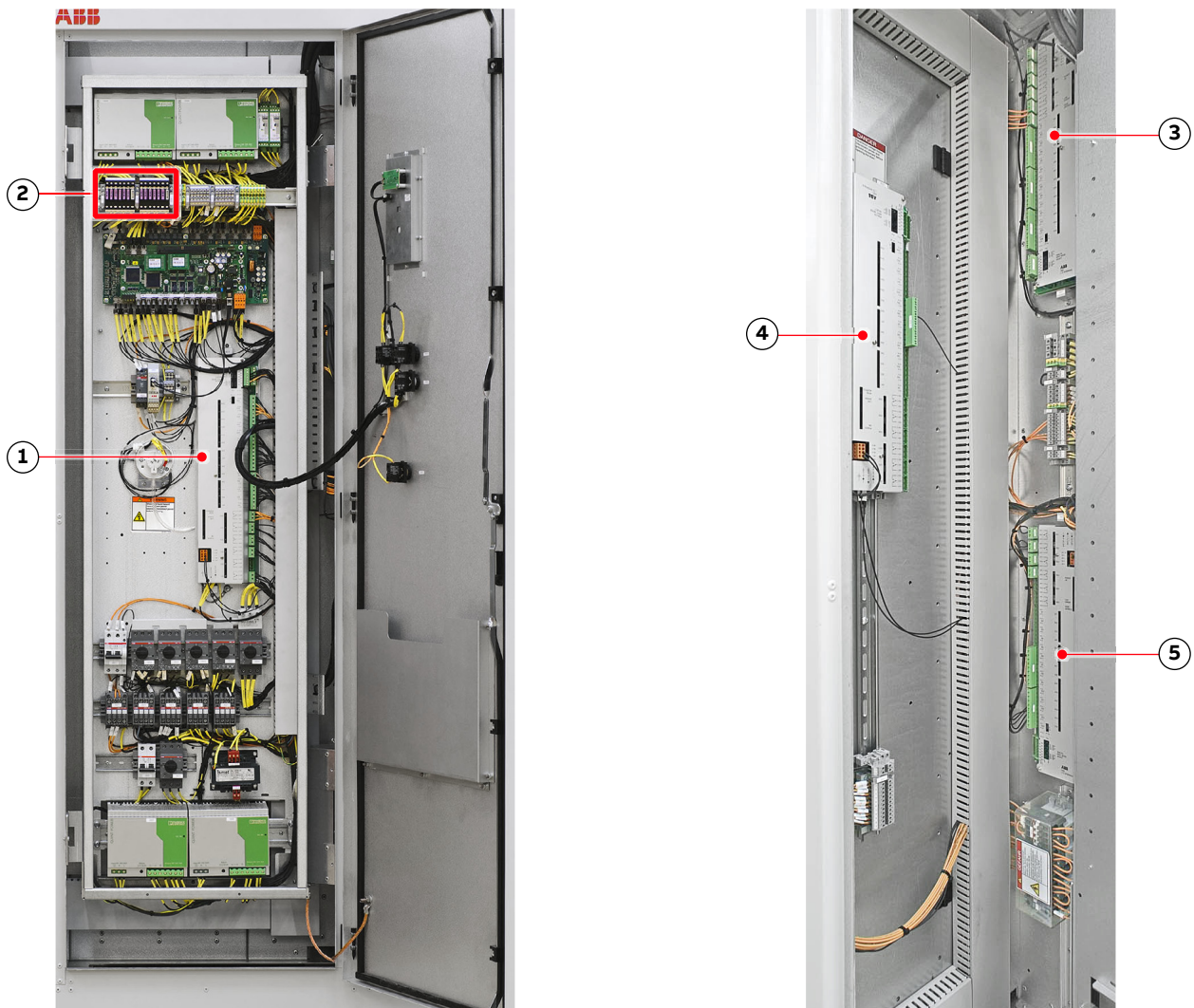

**Key**

- (1) Fuses
- (2) IOEC1 / -A5191 (standard)
- (3) IOEC4 / -A5211 (option)
- (4) IOEC2 / -A5201 (standard)
- (5) IOEC3 / -A5221 (option)

**Figure 73 – Location of I/O modules and fuses**

PRODUCT	DOCUMENT KIND	DOCUMENT ID.	REV.	LANG.	PAGE
ACS1000A	User manual	3BHS213401 E01	N	en	143/160

## 11.6.5. Checking the release conditions for the grounding switch

### 1) Check that the auxiliary voltage is switched on.

### 2) Check that the main power supply is disconnected from the drive.

- Check that the MCB is open – if the MCB is open, secure it against closing.
- Check that the feedback signal **MCB is open** has arrived at the drive, ie, the following indicators are lit:
  - LED of digital input DI08 of I/O module -A5201 (-A2) – if the LED is not lit, check the control-signal wiring between switchgear and drive as per applicable wiring diagram.
  - **Main Supply On** push button -S5152 (-S2) – if the push button is not lit, check if the 24 V blade-type fuse (X27\_P2:14) is blown; the fuse protects the control circuit of the push button.

### 3) Check the discharge level of the DC link.

- Verify that the value of parameter *2.06 DC VOLTAGE* is <50 V.

If the value is below 50 V, the DC link is regarded as discharged. For information on reading actual values on the CDP control panel, see [10.3.2 Actual signals mode on page 114](#).

### 4) Check the Grounding Switch Unlocked lamp and the wiring of the lamp.

- Check if the CDP control panel displays a fault – a fault prevents the lamp **Grounding Switch Unlocked** from lighting.
  - If a fault is present, follow the instructions in [11.3.4 Standard troubleshooting procedure on page 136](#), before you reset a fault.
  - If you cannot rectify and reset the fault, contact the ABB service organization.
- If the CDP control panel does not display a fault, check that digital output DO04 of I/O module -A5191 (-A1) is energized.
  - DO04 releases the grounding switch and lights the lamp **Grounding Switch Unlocked** (-H5152).
  - When the LED of DO04 is lit and the control voltage is present at terminals X24:2 and X24:3 of DO04, DO04 is energized.
- If digital output DO04 of the I/O module is not energized, check the I/O module -A5191 (-A1). To do this, check if the auxiliary voltage is present at the supply terminals of the I/O module.
  - X6:1.....24 V (DC)
  - X6:2.....0 V
- Check that LED V726 and LED V740 of the I/O module -A5191 are lit. The LEDs monitor the control voltages of the I/O module (Figure 72). When the LEDs are lit, the I/O module functions properly.
  - LED V726.....24 V (DC)
  - LED V740.....5 V (DC)
- If digital output DO04 I/O module -A5191 is energized, check that the control voltage is present at the terminals of the lamp **Grounding Switch Unlocked**.
  - If the control voltage is present but the lamp is not lit, the lamp is burnt out and must be replaced.
  - If the control voltage is not present, check the wiring of the lamp. Correct the wiring if necessary.

### 5) Check that hazardous voltages from the motor cannot be fed into the drive.

**IMPORTANT!** When the checklist has been completed, carefully try to turn the grounding switch to the grounded position. If you cannot turn the grounding switch but doors of medium voltage compartments have to be opened, call the ABB service organization.

PRODUCT	DOCUMENT KIND	DOCUMENT ID.	REV.	LANG.	PAGE
ACS1000A	User manual	3BHS213401 E01	N	en	144/160

### 11.6.6. Visual checks on the drive

Check the drive and its immediate vicinity visually at the intervals stated in the maintenance schedule and pay attention to the following items:

- Humidity inside the drive
- Permitted range of ambient air temperature and humidity of the drive
- Dust built-up inside the drive
- Appropriate fastening of cables and wires and connections of cable screens
- Integrity of cable insulation
- Signs for overheated components, wires, cables or busbars
- Corrosion on circuit boards, connectors or busbars
- Correct type of signal and power cables

For more information, see the applicable cable specifications.

### 11.6.7. Cleaning the drive



#### NOTICE

**Risk of component damage!** The drive contains components which are sensitive to electrostatic discharge.

- Apply ESD handling precautions before handling these devices.

Dust on electrical components and wiring can cause failure and damage the components. Dust and moisture can build up in loose connections and cause loss of low-level signals.

- Check the cabinet regularly for signs of dust and humidity and clean if necessary - alcohol and solvents can damage the components.
- Use appropriate and recommended cleansing agents.

#### When cleaning the drive, mind the following:

- To prevent dirt falling into equipment, cover the equipment.
- Clean circuit boards with special care. To prevent the components being damaged, use antistatic brushes and a vacuum cleaner with a soft nozzle.
- Remove dust on assemblies and busbars inside the cabinet with a vacuum cleaner and lint-free cleaning cloths.
- Remove water, oily or greasy deposits on assemblies, components and busbars with water- and oil-absorbing microfibers such as 3M Scotch Brite.
- Use a nylon brush or a vacuum cleaner for removing dust or deposits from recesses.
- Clean the outside of the cabinet with a vacuum cleaner and cleaning cloths.

PRODUCT	DOCUMENT KIND	DOCUMENT ID.	REV.	LANG.	PAGE
ACS1000A	User manual	3BHS213401 E01	N	en	145/160

## 11.6.8. Checking wire and cable connections

### NOTICE

**Risk of component damage.** Capacitor bushings are damaged when excessive force is applied.

- DO NOT exceed the maximum tightening torque; the tightening torque value is printed on a label which is attached to the capacitor. If not specified, the maximum torque must not exceed 20 Nm.

Vibration can loosen electrical connections and cause occasional malfunction or equipment failure.

- Inspect all power and control cable connections and tighten them if necessary.
- Inspect that all plugs and connectors are tight.

## 11.6.9. Cleaning and replacing filter mats

The filter mats are in the control as the inverter compartments.

For information on inspection and replacement intervals, see the “ACS1000A preventive maintenance schedule”, 3BHS855276 E01.

**Table 17 – Filter mat specifications**

Drive compartment	ABB ID	Dimensions (L × W)	Filter class (EN779)	Filter type
Control	3BHL001134P0001	132 × 320 mm	G4	T15/350
Inverter	3BHL001141P0001	818 × 1228 mm	G3	T15/150

### 11.6.9.1. Control compartment filter mat

#### NOTICE

**Risk of component damage!** Dust can damage components and cause failure when the drive is energized.

→ Always clean the filter mat at a safe distance from the open cabinet door.

1. Open the door of the control compartment.  
NOTE – You can open the door when the drive is running.
2. Pull the filter out of the sleeve at the bottom.
3. Depending on its condition, clean or replace the filter mat:
  - Clean the filter mat with compressed air or a vacuum cleaner and slide the filter mat back into the sleeve.
  - Slide a new filter mat (see Table 17) into the sleeve.

### 11.6.9.2. Rectifier and inverter compartment filter mat



#### WARNING

**Hazardous voltage!** Removing the filter mat while the drive is running can cause serious injury or DEATH. Foreign objects can be sucked into the exposed air intake and cause FATAL short-circuits.

- Keep long, thin objects, such as wires and screwdrivers, away from the exposed air intake.
- DO NOT stop work for long periods while the air intake is exposed.

#### NOTICE

**Risk of component damage!** Dust can damage components and cause failure when the drive is energized.

→ Always clean the filter mat at a safe distance from the open cabinet door.

PRODUCT	DOCUMENT KIND	DOCUMENT ID.	REV.	LANG.	PAGE
ACS1000A	User manual	3BHS213401 E01	N	en	147/160

Referring to Figure 74:

1. Set parameter *41.47 FILTER MAT CHANGE FUNCTION* to **ENABLE**.

The monitoring of differential air pressure is disabled for the time that is defined in parameter *41.48 FILTER MAT CHANGE TIME* (default 30 minutes).

**NOTICE** The drive might trip if the filter mat is not replaced before the time elapses.

2. Remove the 6 screws (circles) from the louvered panel (1, Figure 74).

NOTE – Depending on your drive, you might need a slot or Torx screwdriver.

3. Remove the louvered panel.

4. Starting at the top, roll the filter mat (2, Figure 74) down to remove it.

5. Depending on its condition, clean or replace the filter mat.

- Clean the filter mat with compressed air or a vacuum cleaner.
- Replace the filter mat with a new one (see Table 17).

6. Reinstall the louvered panel (1, Figure 74) with the 6 screws (circles).



**Figure 74 – Filter panel (1) and filter mat (2) on rectifier and inverter compartment**

### 11.6.10. Inspecting and replacing batteries

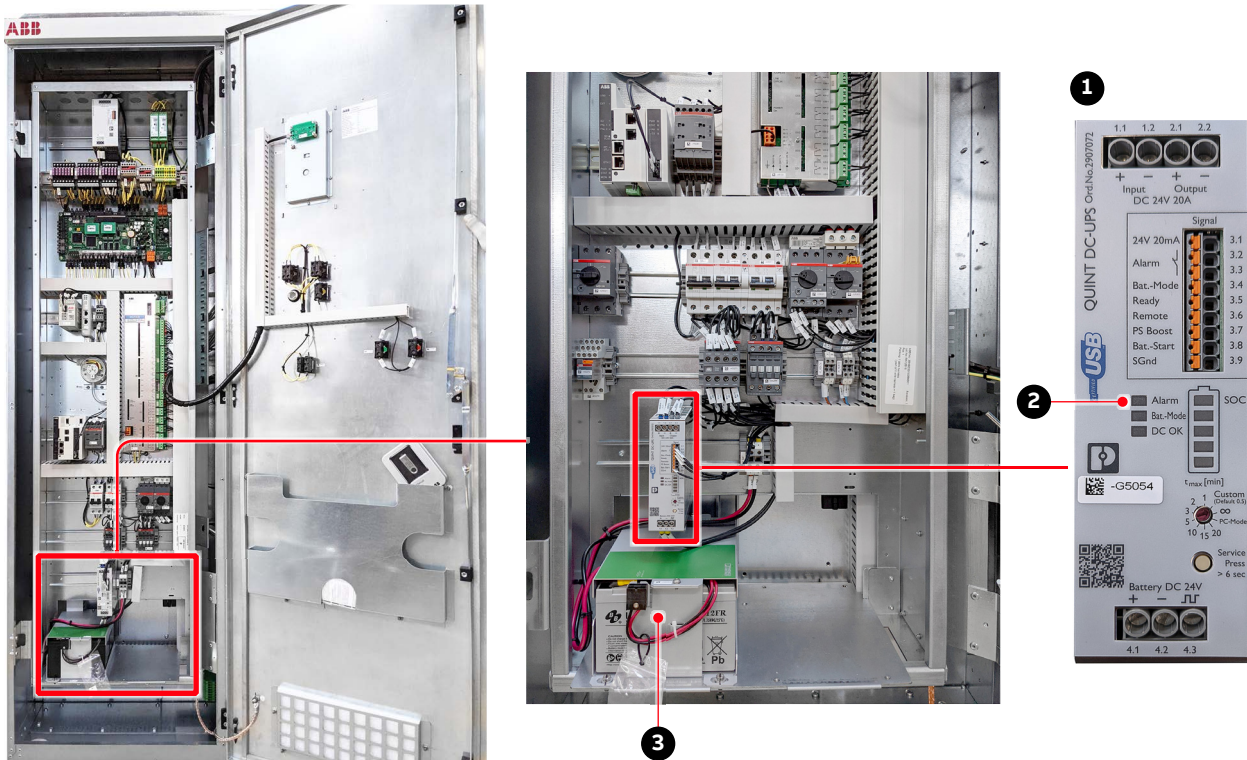

**Key**

- (1) Power supply unit for battery pack 1
- (2) Alarm LED
- (3) Battery pack 1

**Figure 75 – Control compartment – battery location**

#### 11.6.10.1. Checking and replacement indications

The end of the battery life is indicated as follows:

- CDP control panel displays an alarm message.
- Alarm LED on the power supply unit for the battery lights up (2, Figure 75).

When the end of the battery life is indicated, the drive continues to operate until the time set with parameter *145.26 Batt-Alm.Tim-out* has elapsed.

ABB recommends replacing all of the batteries when one battery is at end-of-life.

PRODUCT ACS1000A	DOCUMENT KIND User manual	DOCUMENT ID. 3BHS213401 E01	REV. N	LANG. en	PAGE 149/160
---------------------	------------------------------	--------------------------------	-----------	-------------	-----------------

### 11.6.10.2. Replacing a battery



**CAUTION**

**Heavy object.** A battery weighs approximately **10 kg!**

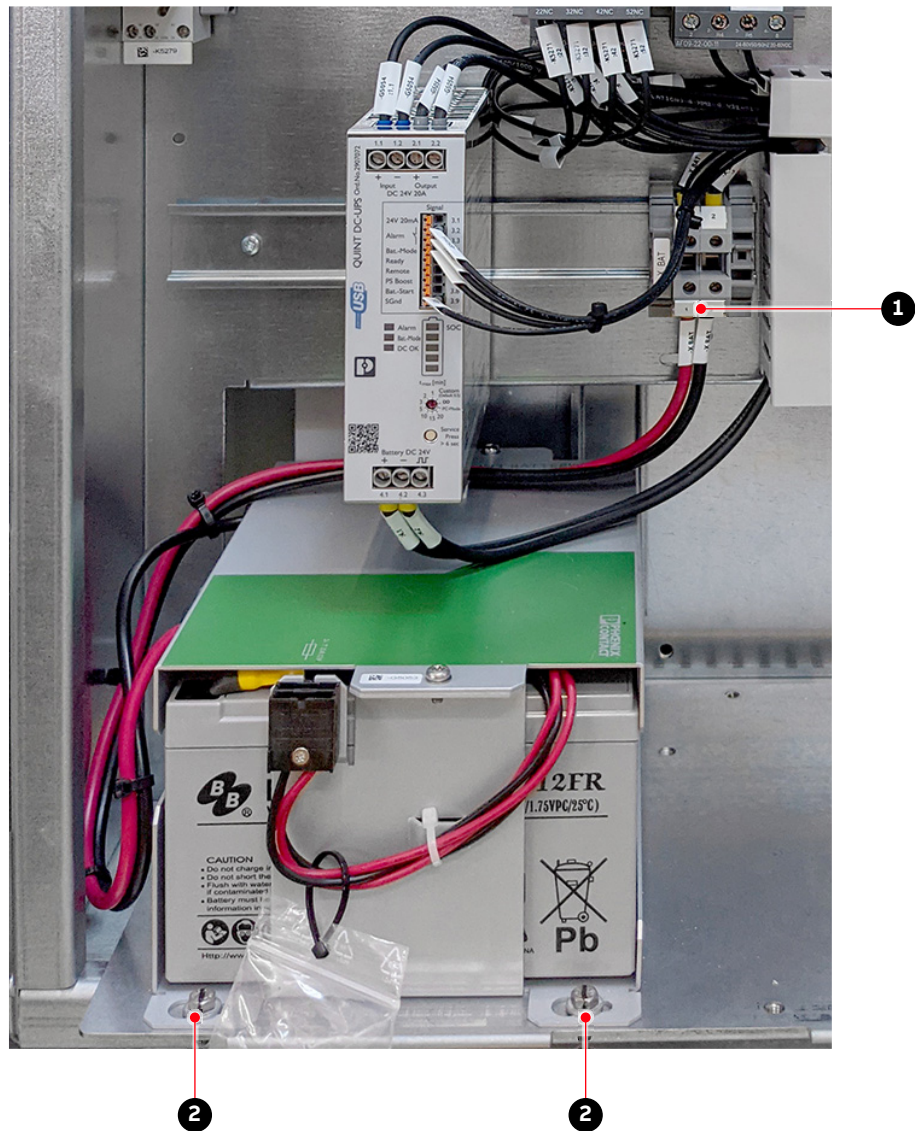

**Figure 76 – Control compartment - replacing the batteries**

1. When the drive is in operation, disable the battery monitoring function first. To do this, set parameter *31.05 DISABLE BATTERY TEST* to **ON**.  
Parameter *31.05* is automatically set to **OFF** after 1 hour.
2. Disconnect the wires (1, Figure 76).
3. Unbolt the battery from the plate at the front (2, Figure 76) and at the back.
4. Install the new battery in reverse order of removal.
5. Record the date of battery replacement in the logbook.

PRODUCT	DOCUMENT KIND	DOCUMENT ID.	REV.	LANG.	PAGE
ACS1000A	User manual	3BHS213401 E01	N	en	150/160

### 11.6.11. Replacing the non-redundant fan



**CAUTION**

**Heavy object.** The fan weighs approximately 100 kg.

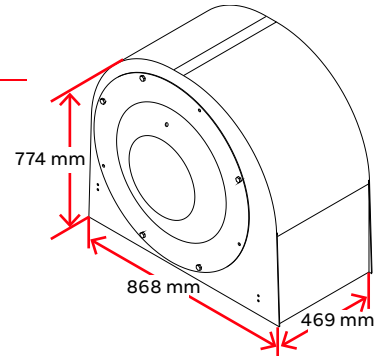
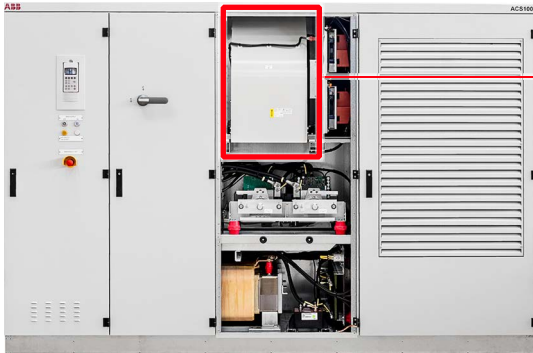

Figure 77 – Fan location, dimensions and weight



**Key**

- (1) 1/4"
- (2) ~70 mm
- (3) 10 mm and 13 mm
- (4) Trolley
- (5) Lift truck

Figure 78 – Fan - tools and devices

1. Disconnect all power supplies to the drive and ground the drive according to [11.6.2 De-energizing the drive locally on page 141](#).
2. Switch off the motor starter of the fan.  
The fan is now isolated from the auxiliary power supply.
3. Measure to confirm the absence of voltage.
4. Unplug the power supply cable (1, Figure 79) of the fan.
5. Remove the bolts (2, Figure 79).  
**IMPORTANT!** DO NOT drop washers and bolts into the cabinet.
6. Move the fan onto the lift truck by one of the following methods:
7. Place the lift truck or height-adjustable trolley in front of the fan and pull the fan onto the platform.

PRODUCT	DOCUMENT KIND	DOCUMENT ID.	REV.	LANG.	PAGE
ACS1000A	User manual	3BHS213401 E01	N	en	151/160

8. Unplug the optical fibers (V3001:A1, V3002:A1) from the protection IGCTs (3, Figure 79) and stow the optical fibers in a position where they cannot be damaged when the fan is replaced.

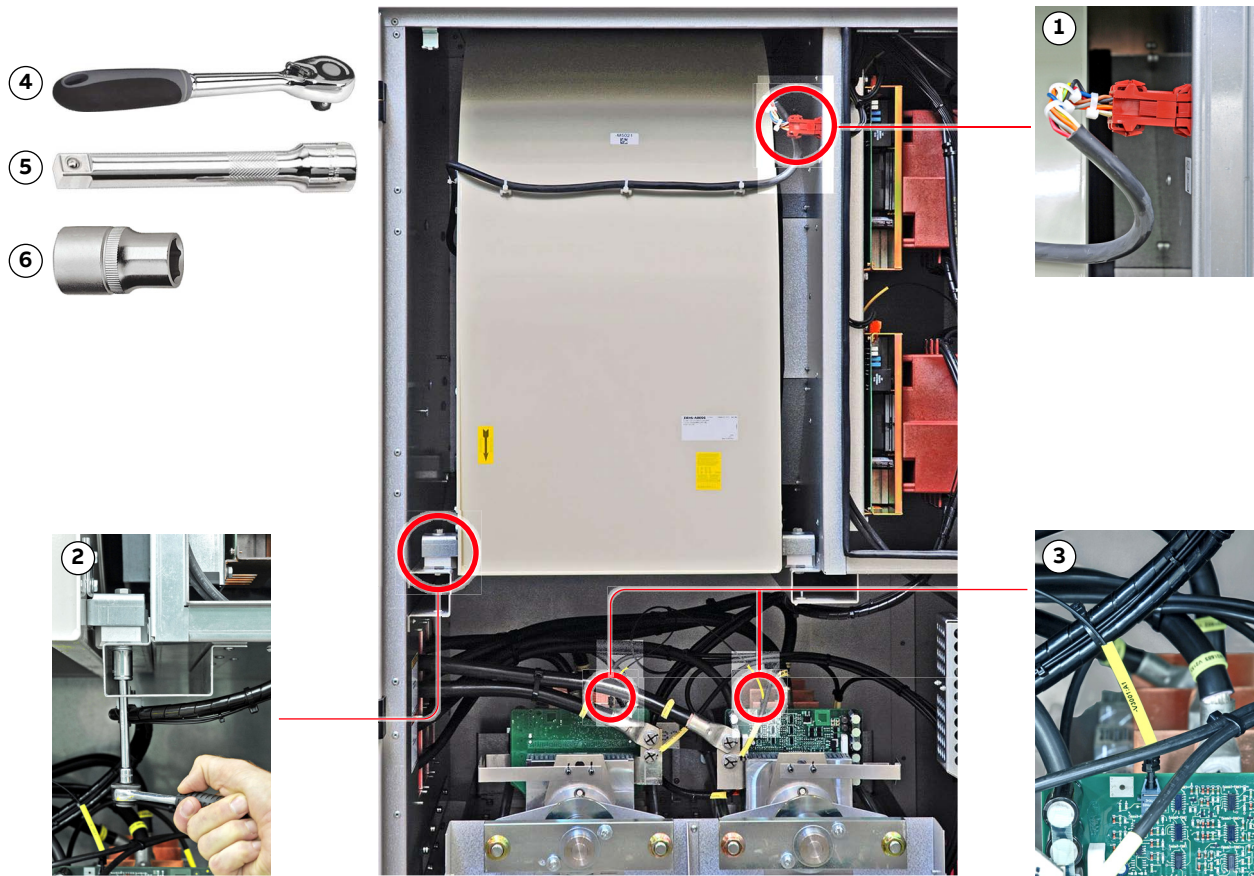

**Key**

- |                          |            |
|--------------------------|------------|
| (1) Power supply cable   | (4) ¼"     |
| (2) Bolts                | (5) ~70 mm |
| (3) Optical fiber cables | (6) 13 mm  |

**Figure 79 – Replacing the non-redundant fan**

9. Push the lift truck under the fan, ensure that the lift truck does not catch cables and components and lift the fan a little and remove it from the cabinet while avoiding sudden movements.

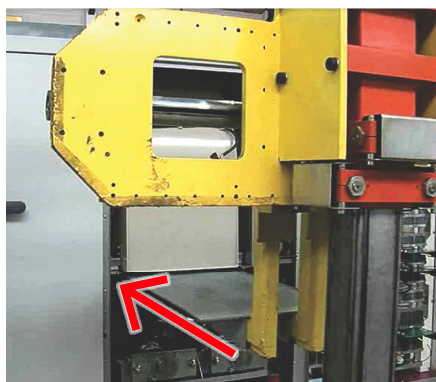

### 11.6.11.1. Installing the non-redundant fan

1. Check the mounting supports (1, Figure 80).
2. If they are damaged, replace them.
3. If they can be re-used, attach them to the new fan.
4. On both sides of the fan, orientate the groove of the mounting supports (2, Figure 80) towards the back of the cabinet.

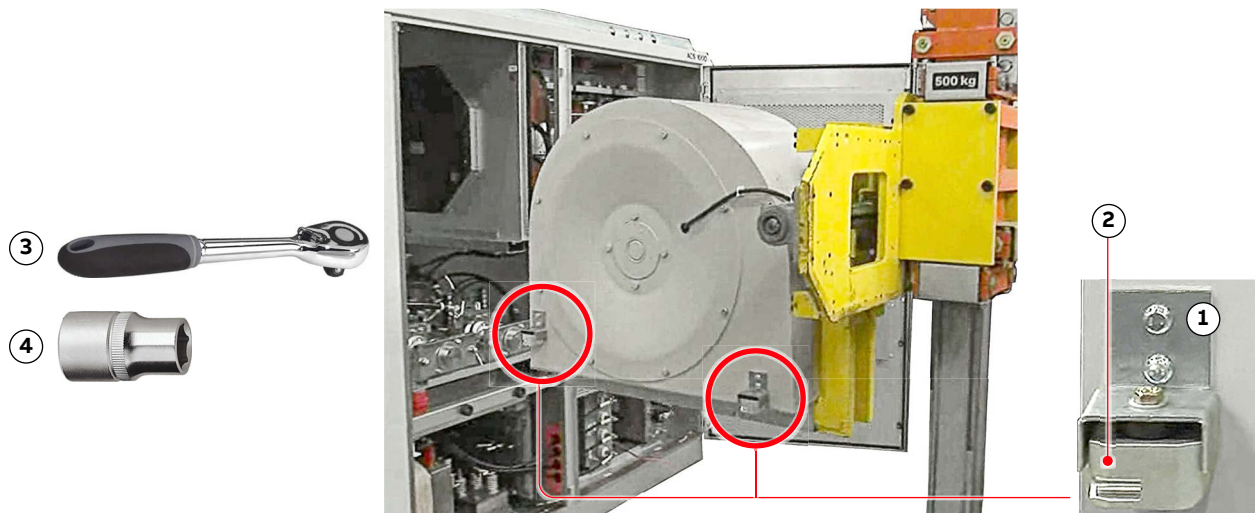

#### Key

- (1) Mounting supports
- (2) Groove
- (3) 1/4"
- (4) 10 mm

**Figure 80 – Installing the non-redundant fan**

5. Check that all screws are properly fastened.
6. Install the new fan in reverse order of removal.

PRODUCT	DOCUMENT KIND	DOCUMENT ID.	REV.	LANG.	PAGE
ACS1000A	User manual	3BHS213401 E01	N	en	153/160

### 11.6.12. Replacing a redundant fan

For information on inspection and replacement intervals, see “ACS1000A preventive maintenance schedule”, 3BHS855276 E01.

The estimated working time to replace a redundant fan is approximately 1 hour.



**CAUTION**

**Heavy object.** The fan weighs approximately 100 kg.

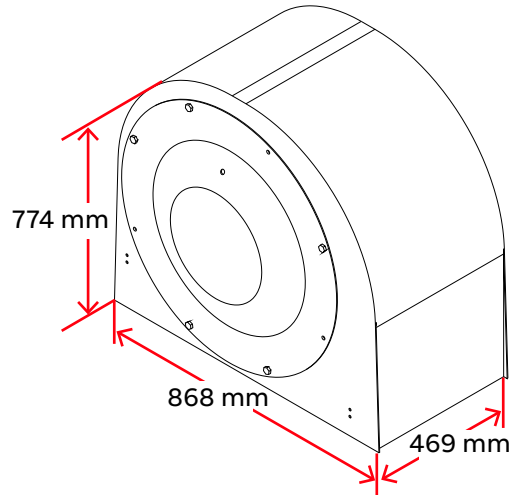

**Figure 81 – Redundant fans – location, dimensions, and weight**



**Key**

- (1) ¼"
- (2) ~70 mm
- (3) 13 mm and 17 mm
- (4) 13 mm
- (5) T 30

**Key**

- (6) Cordless drill
- (7) 3 × M10×20
- (8) Height-adjustable platform
- (9) Lift truck

**Figure 82 – Redundant fans - tools and devices**

PRODUCT	DOCUMENT KIND	DOCUMENT ID.	REV.	LANG.	PAGE
ACS1000A	User manual	3BHS213401 E01	N	en	154/160

## Procedure

1. Disconnect all power supplies to the drive and ground the drive according to [11.6.2 De-energizing the drive locally on page 141](#).
2. Switch off the motor starter of the fan.  
The fan is now isolated from the auxiliary power supply.
3. Measure to confirm the absence of voltage.
4. Remove the panels.
5. If the fan is removed towards the front of the cabinet, the top panel can stay on the cabinet.
6. If the rear panel is not accessible, remove the sound absorbing panels on the side where the fan is replaced.

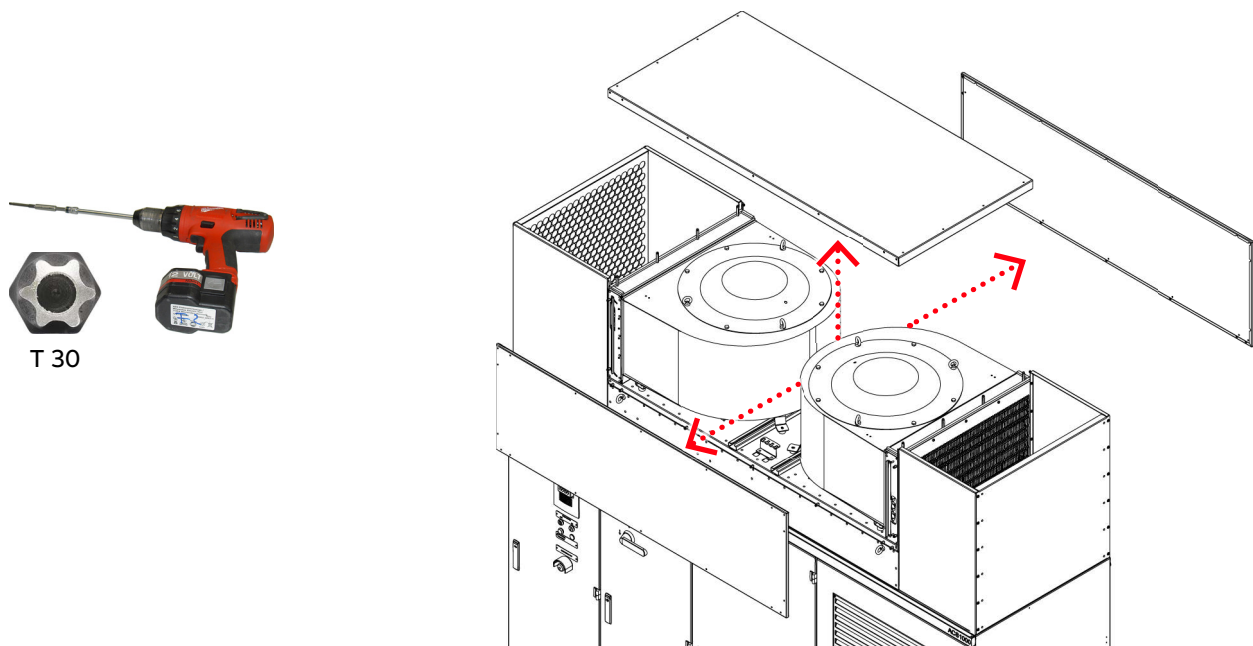

**Figure 83 – Redundant fan unit – removing the panels**

PRODUCT ACS1000A	DOCUMENT KIND User manual	DOCUMENT ID. 3BHS213401 E01	REV. N	LANG. en	PAGE 155/160
---------------------	------------------------------	--------------------------------	-----------	-------------	-----------------

- Unplug the power supply cable.

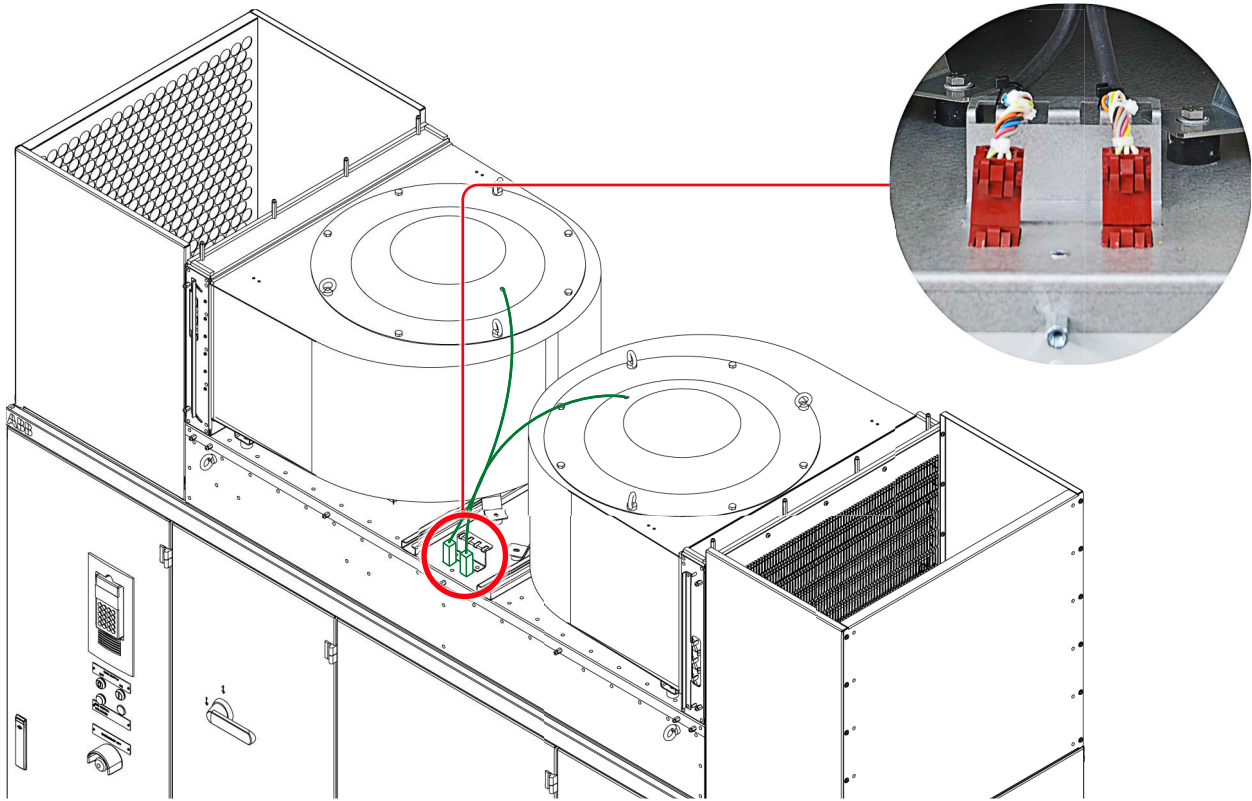
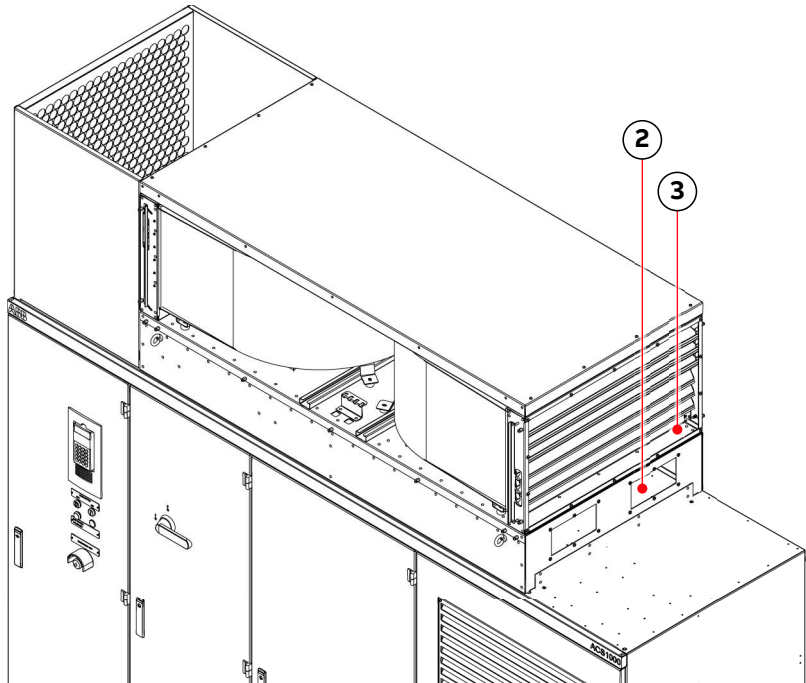
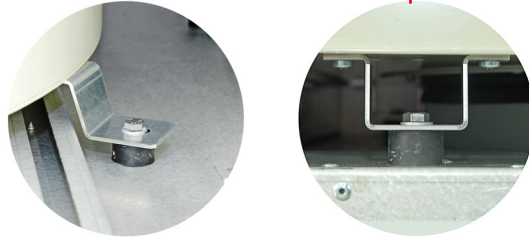
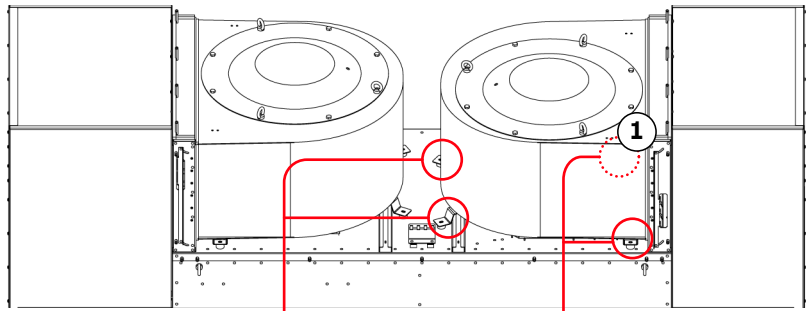

**Figure 84 – Redundant fan unit – Unplugging the power supply cable**

- Remove the fixing bolts.

**NOTE** – If the bolt at the back (1, Figure 85) is not accessible from the back of the cabinet, remove the cover (2, Figure 85), reach through the opening and unscrew the mounting support (3, Figure 85) from below.

PRODUCT	DOCUMENT KIND	DOCUMENT ID.	REV.	LANG.	PAGE
ACS1000A	User manual	3BHS213401 E01	N	en	156/160



**Key**

- (1) Bolt
- (2) Cover
- (3) Mounting support
- (4) ¼"
- (5) 13 mm
- (6) 13 mm
- (7) Cordless drill
- (8) T 30

**Figure 85 – Redundant fan unit – removing the fixing bolts**

9. Remove the fan by one of the following methods:

- **Crane:** replace 3 of the fixing bolts with eye bolts, attach the lifting gear to the eye bolts and then lift the fan off the cabinet.

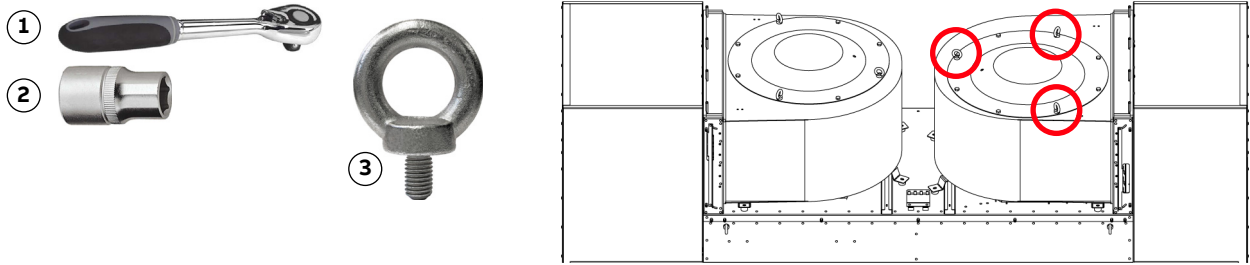

**Key**

- (1) 1/4"
- (2) 17 mm
- (3) 3 x M10 x 20

**Figure 86 – Redundant fan unit – using a crane**

- **Height-adjustable platform:** place the platform as close as possible to the fan and then pull the fan onto the platform.

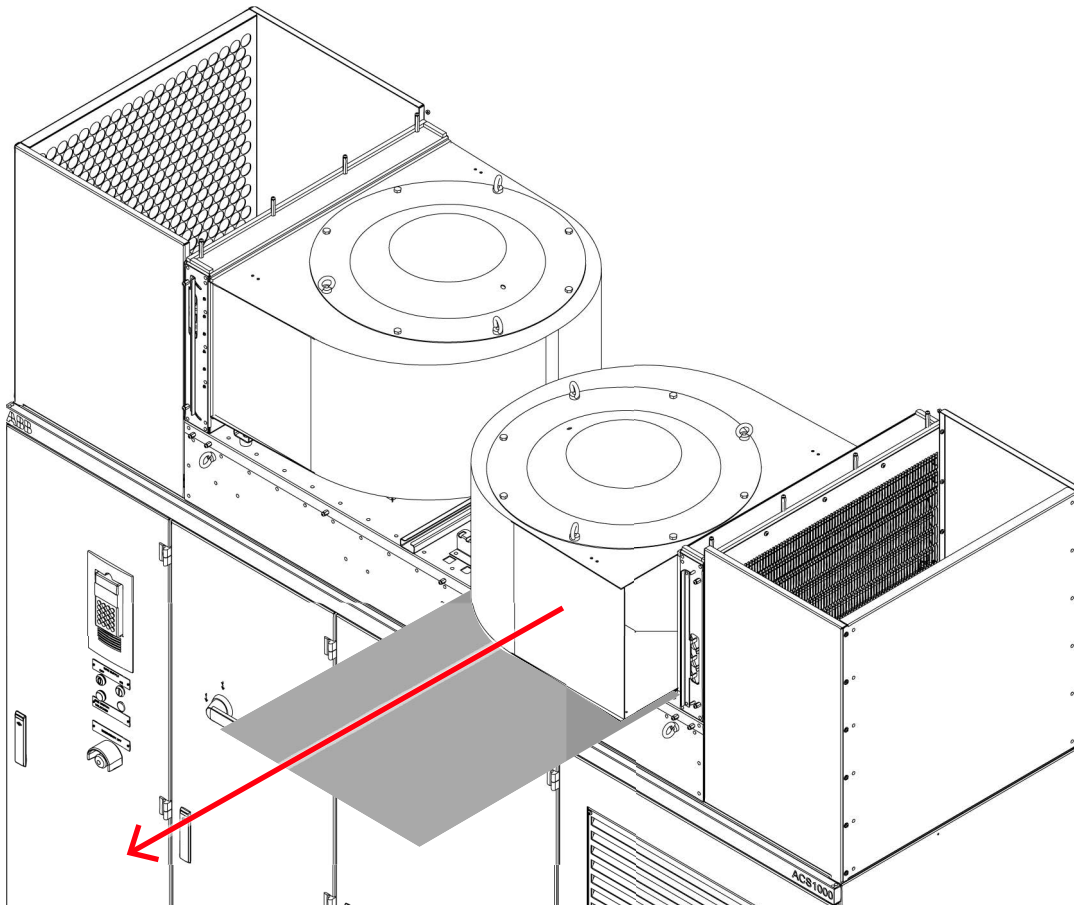
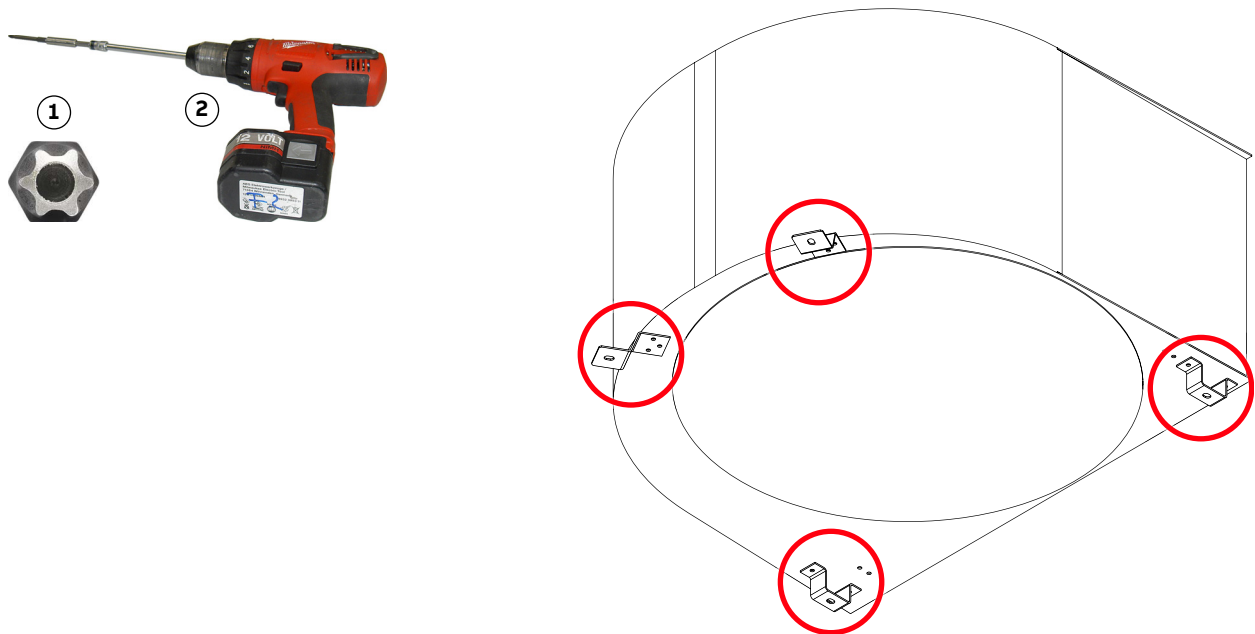

**Figure 87 – Redundant fan unit – using a platform**

10. Remove the mounting supports from the fan housing to be replaced and attach the mounting supports to the new fan housing.

11. If the new fan housing does not have screw holes for the mounting supports, drill holes into the underside of the fan housing.

For information on the exact hole positions, see drawing number 3BHS128478 E01 in “Appendix C - Mechanical drawings”.



12. Check that all screws are properly fastened.
13. Install the new fan in reverse order of removal.



---

**ABB Switzerland Ltd.**

Bruggerstrasse 66  
CH-5400 Baden  
Switzerland

[new.abb.com/drives/medium-voltage-ac-drives](https://new.abb.com/drives/medium-voltage-ac-drives)